

Base Station

User Manual

Weather Stations

Parts 1723-XA 1-11X (Firmware version 2436-4.03.00)

Parts 1723-XC 1-X1X (Firmware version 2436-4.03.00)

Parts 1723-XA X-13X (Firmware version 2917-4.03.00 Modbus units only)

Parts 1723-XC X-13X (Firmware version 2917-4.03.00 Modbus units only)

Doc No: 1723-PS-0023

Issue 3



**MetPak
Base Station**



**MetPak Pro
Base Station**

Gill Instruments Limited
Saltmarsh Park, 67 Gosport Street, Lymington,
Hampshire, SO41 9EG, UK

Tel: +44 1590 613500, Fax: +44 1590 613555

Email: contact@gillinstruments.com

Website:

 Contents

1.	FOREWORD.....	5
2.	INTRODUCTION.....	5
2.1.	MetPak Base Station Part Numbers and Parameters.....	6
2.1.1.	MetPak Base Station Part Number Structure.....	6
2.1.2.	MetPak Base Station Derived Parameters and Sensors.....	6
2.1.3.	Wind Speed and Direction Sensors.....	7
2.1.4.	Radiation Shield.....	9
2.1.5.	Temperature, Relative Humidity and Dewpoint.....	9
2.1.6.	Barometric Pressure.....	9
2.1.7.	Precipitation (Digital Input 1).....	10
2.1.8.	PRT Temperature (PRT Input).....	10
2.1.9.	Analogue Sensor 1.....	10
2.1.10.	Analogue Sensor 2.....	10
2.1.11.	Status of MetPak Sensors.....	10
2.1.12.	Supply Voltage.....	10
2.2.	MetPak Base Station Range default ASCII Output Summary.....	11
3.	TECHNICAL SPECIFICATION.....	12
4.	PRE-INSTALLATION	15
4.1.	Equipment supplied	15
4.1.1.	Optional Extras:.....	15
4.2.	Base Station Anemometer 10 Metre Cable Assembly.....	16
4.2.1.	WindSonic and WindMaster Clipper Connector Assembly Details.....	16
4.2.2.	WindObserver (Non Heated units) Connector Assembly Details.....	19
4.2.3.	WindSonic M Heated units Connector Assembly Details.....	19
4.2.4.	WindObserver Heated units Connector Assembly Details.....	20
4.3.	Communication Cabling.....	20
4.3.1.	Communication and Power Cable type.....	21
4.3.2.	Cable Length.....	21
4.4.	Cable Connections General.....	22
4.5.	Earthing.....	22
4.6.	Power Supplies.....	22
4.7.	Power and Communication Connections.....	23
4.8.	Connecting to a PC using Gill RS232 to USB Configuration Cable.....	24
4.9.	Connecting to a PC using RS232 (Default setting).....	27
4.10.	Connecting to a PC using RS422 (Not a Default Setting).....	27
4.11.	Using RS485 (2 wire point to point only, not a default setting).....	28
4.12.	Using SDI-12 (2 wire network) not a default setting.....	28
4.13.	Analogue, Digital and PRT Input Connections.....	29
4.14.	MetPak Pro Base Station Junction Box (Part 1723-PK-021).....	33
4.15.	Set up requirements.....	37
4.15.1.	Host System:.....	37
4.15.2.	Software:.....	37
4.15.3.	Bench system test.....	37
4.16.	Packaging.....	37
5.	INSTALLATION.....	38
5.1.	Example System Installations.....	38
5.1.1.	Non Heated Wind Sensor System.....	38
5.1.2.	Heated Wind Sensor System.....	40
5.2.	Interference.....	42

5.3.	Wind Sensor Installation	42
5.4.	MetPak Base Station Range Mounting and Dimensions (in mm)	43
5.5.	MetPak Pro Base Station Junction Box Mounting (1723-PK-021)	45
5.6.	Mounting MetPak Base Station Heater Power Interface Box (Optional Item part 1723-PK-099)	47
5.7.	Solar Installation	48
6.	CONFIGURING WITH METSET	49
6.1.	MetPak Base Station Default Configurations	49
6.2.	Configuring MetPak Range Base Stations with MetSet.....	52
6.3.	Configuring a Base Station for Polled Mode.....	63
6.3.1	To Configure a Base Station Unit for Polled Mode:.....	63
6.3.2	Using Polled Mode:.....	63
6.4.	Configuring a Base Station for SDI-12	64
6.4.1.	SDI-12 Units of Measure	64
6.4.2.	SDI-12 Commands	65
6.4.3.	SDI-12 Commands with CRC.....	67
6.5.	Configuring a Base Station for MODBUS.....	69
6.5.1	Base Station Supported Modbus Specification	69
6.6.	Configuring a MetPak Base Station for NMEA Output.....	74
6.7.	Safe Mode	76
6.7.1.	Safe Mode Method 1	76
6.7.2.	Safe Mode Method 2	80
7.	VIEWING METPAK BASE STATION DATA.....	81
7.1.	Use MetView to View the Base Station Data.....	81
7.1.1.	Opening MetView	81
7.1.2.	Scanning for Devices.....	82
7.1.3.	The MetView Console.....	83
7.1.4.	MetPak Pro Base Station User External Sensor Display Example	84
7.1.5.	MetView Console Display Options	85
7.1.6.	MetView Gauge Ranges and Graphs.....	86
7.1.7.	Data logging.....	88
7.2.	Use a Terminal Program to View the Base Station Data.....	90
7.2.1.	Setting up a logging file	92
7.2.2.	To stop logging	92
8.	MAINTENANCE & FAULT-FINDING	93
8.1.	Cleaning and Handling.....	93
8.2.	Servicing.....	93
8.2.1.	Wind Sensors	93
8.2.2.	UV Radiation Shield (MetSpec).....	93
8.2.3.	Barometer	94
8.2.4.	Temperature, Humidity and Dewpoint Probe (Rotronic HC2A-S3-GI)	94
8.2.5.	Solar Sensor	95
8.2.6.	Calibration.....	95
8.2.7.	Returning the Base Station.....	95
8.3.	Fault-finding.....	96
8.3.1.	Fault Symptoms/Solutions.....	96
8.3.2.	MetPak Base Station Range Sensor Status Codes	97
8.4.	Safe Mode	98
8.5.	Bench Test	98
8.6.	Returning Units.....	98
8.7.	Guarantee.....	98

9.	APPENDICES.....	99
9.1.	Glossary & Abbreviations.....	99

1. FOREWORD

Thank you for purchasing a MetPak Base Station unit manufactured by Gill Instruments Ltd. To achieve optimum performance we recommend that you read the whole of this manual before proceeding with use.

Gill products are in continuous development and therefore specifications may be subject to change and design improvements without prior notice.

The information contained in this manual remains the property of Gill Instruments and should not be copied or reproduced for commercial gain.

2. INTRODUCTION

All the MetPak Base Station range equipments are Professional multi-sensor instruments that measure the most essential weather parameters. They also provide a data collection system that allows customers to add their own selection of sensors to meet local requirements.

Wind Measurement can be chosen from a variety of 2 and 3 axis Gill anemometers, please refer to section 2.1.3 for the full list of compatible sensors.

Temperature and Humidity are measured and Dewpoint calculated using an industry standard probe housed in a naturally aspirated radiation shield. Barometric pressure is measured using an industry standard sensor.

The MetPak Pro Base Station allows in addition for the customer to use a tipping bucket for rain measurements and add up to four sensors. One PRT (temperature sensor), one digital (contact closure rain gauge) and two analogue inputs (4-20mA or 0-5V) e.g. water level sensor, Pyranometer, pressure sensor, soil temperature etc. Other types of sensors may be added limited by the number of inputs available.

MetPak Range Base Stations combine all the instrument data into a single combined data string. They may be configured for digital ASCII RS232/RS422/RS485 (2 wire point to point), digital MODBUS RTU/ASCII and SDI-12 outputs.

The Base Station electrical Hub box comes with a pre-installed 10 Metre cable to connect to a Gill Wind Sensor. There is one cable gland for the installed Temperature/Humidity sensor. There is one cable gland allocated to provide entry for termination of other sensors and one cable gland for data/power cables.

A separate Junction box (optional accessory) is available for termination of external sensors, power and communication cables.

A separate Heater Interface box (optional accessory) allows for termination of the Base Station 10 Metre cable to a heated Wind Sensor and Heater power supply.

The instrument uses a rugged mounting clamp that attaches to any vertical pipe up from 30mm to 58mm diameter.

Base Station (10 Metre cable not shown)

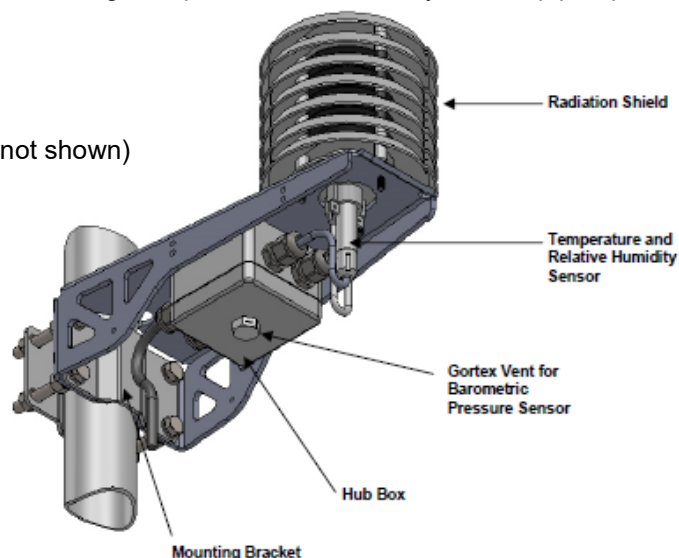

2.1. MetPak Base Station Part Numbers and Parameters

2.1.1. MetPak Base Station Part Number Structure.

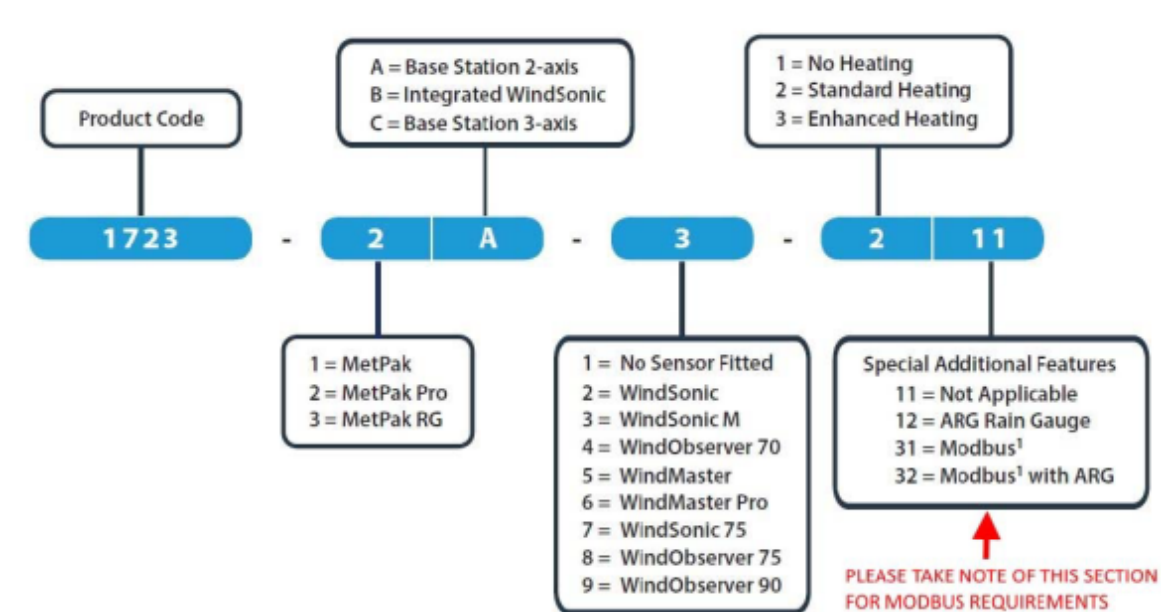

2.1.2. MetPak Base Station Derived Parameters and Sensors.

MetPak-Sensor-Parameters ^α	MetPak ^α	MetPak-RG ^α	MetPak-Pro ^α
Wind-Speed, -Relative ^α	Yes ^α	Yes ^α	Yes ^α
Wind-Direction, -Relative ^α	Yes ^α	Yes ^α	Yes ^α
Temperature, -Air ^α	Yes ^α	Yes ^α	Yes ^α
Humidity, -Relative ^α	Yes ^α	Yes ^α	Yes ^α
Dewpoint ^α	Yes ^α	Yes ^α	Yes ^α
Barometric-Pressure ^α	Yes ^α	Yes ^α	Yes ^α
Rain/Precipitation ^α	No ^α	Yes ^α	Yes-with-user-supply-Rain-Gauge ^α
Temperature-from-a-PRT ^α	No ^α	No ^α	Yes-with-user-supply-PRT ^α
Analogue-Sensor-1 ^α	No ^α	No ^α	Yes-with-user-supply-Sensor ^α
Analogue-Sensor-2 ^α	No ^α	No ^α	Yes-with-user-supply-Sensor ^α
MetPak-Derived-Parameter ^α	MetPak ^α	MetPak-RG ^α	MetPak-Pro ^α
Status-(Sensors) ^α	Yes ^α	Yes ^α	Yes ^α
Volts-(Supply) ^α	Yes ^α	Yes ^α	Yes ^α
MetPak-Outputs ^α	MetPak ^α	MetPak-RG ^α	MetPak-Pro ^α
Gill-ASCII ^α	Yes ^α	Yes ^α	Yes ^α
Modbus ^α	Yes ^α	Yes ^α	Yes ^α
SDI-12 ^α	Yes ^α	Yes ^α	Yes ^α
NMEA ^α	Yes ^α	No ^α	No ^α

2.1.3. Wind Speed and Direction Sensors

The MetPak Range Base Stations can be used with Gill 2 axis (WindSonic or WindObserver) or 3 axis (WindMaster or WindMaster Pro) wind speed and direction sensors. They are connected via the supplied MetPak Hub Box RS422 communication and power 10 Metre cable.

MetPak Base Station Wind Sensors measure the times taken for an ultrasonic pulse of sound to travel from the North (N) transducer to the South (S) transducer, and compares it with the time for a pulse to travel from S to N transducer. Likewise times are compared between West (W) and East (E), and E and W transducer.

If, for example, a North wind is blowing, then the time taken for the pulse to travel from N to S will be faster than from S to N, whereas the W to E, and E to W times will be the same. The wind speed and direction can then be calculated from the differences in the times of flight on each axis. This calculation is independent of factors such as temperature.

The compass point and polarity of U and V if the wind components along the U and V axis are blowing in the direction of the respective arrows.

Wind Sensor Base Station units output Relative wind – wind speed and/or direction relative to the north marker.

WindSonic Range North Marker and UV Wind Components

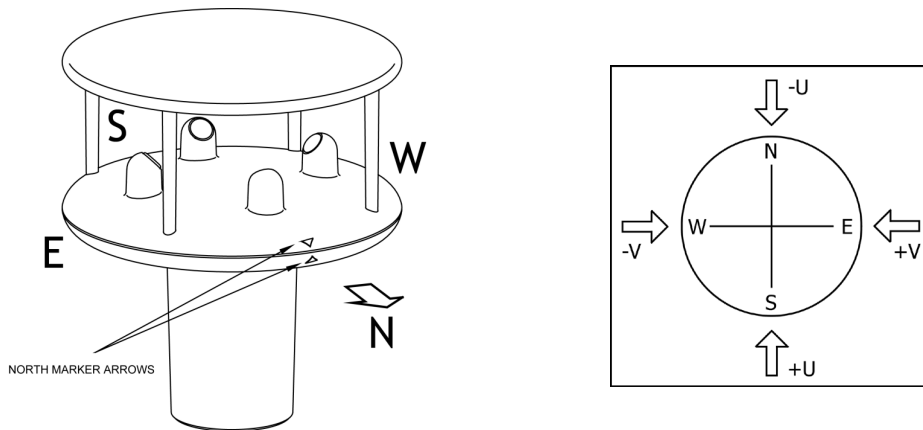

WindObserver Range North Marker and UV Wind Components

Align the WindObserver using the North Transducer Arm.

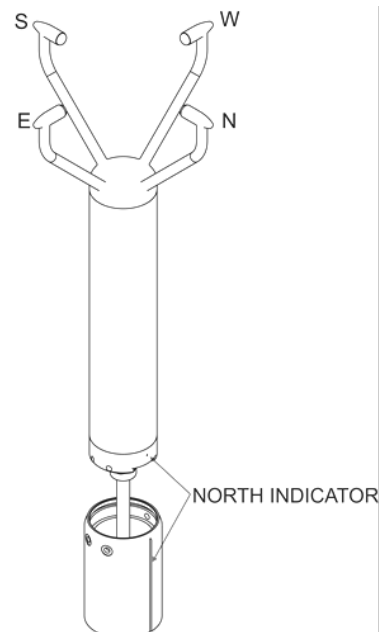

WindMaster Range North Marker and UVW Components

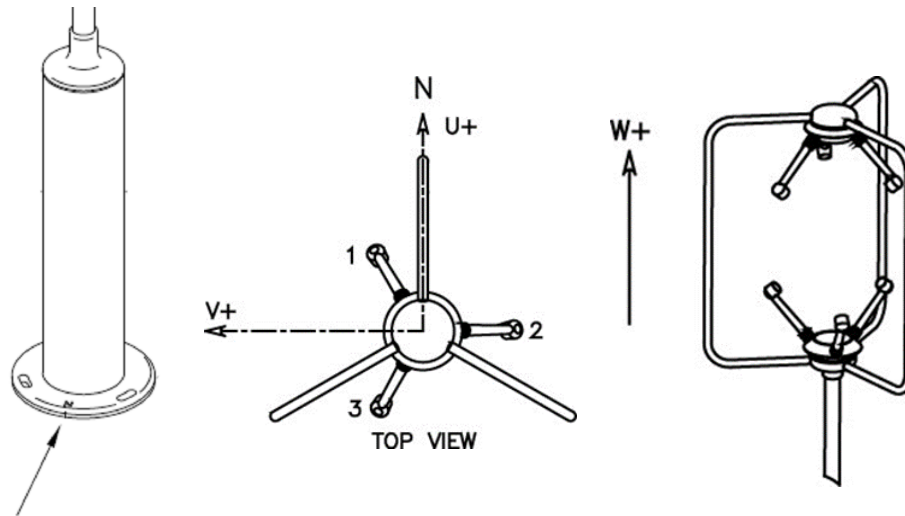

North alignment symbol and notch

2 Axis Base Station using WindSonic and required Configuration Settings:-

1405-PK-038	WindSonic Option 2 Black
1405-PK-040	WindSonic Option 3 Black
1405-PK-072	WindSonic Option 2 White
1405-PK-073	WindSonic Option 3 White
1405-PK-420	WindSonic 75 Option 2 Black
1405-PK-423	WindSonic 75 Option 3 Black
Configuration Setting M4,U1,O1,L1,P1,B4,H2,NQ,F1,E2,T1,S4,C2,G0,K0,	

2 Axis Base Station using WindSonic M and required Configuration Settings:-

1405-PK-200	WindSonic M Heated
1405-PK-201	WindSonic M Heated
1405-PK-300	WindSonic M Unheated
1405-PK-301	WindSonic M Unheated
Configuration Setting M4,U1,O1,L1,P1,B4,H2,NQ,F1,E2,T1,S4,C2,G0,K0,	

2 Axis Base Station using WindObservers and required Configuration Settings:-

1390-65-X-XXX	WindObserver 65
1390-70-X-XXX	WindObserver 70
1390-75-X-XXX	WindObserver 75
1390-90-X-XXX	WindObserver 90
Configuration for Non-Heated WindObserver is:-	
A0,B4,C1,E1,F1,G0000,H1,J1,K1,L1,M4,NQ,O1,P1,T1,U1,V1,X1,Y1,Z1	
Configuration for Heated WindObservers is:-	
A0,B4,C1,E1,F1,G0000,H2,J1,K1,L1,M4,NQ,O1,P1,T1,U1,V1,X1,Y1,Z1	
Note – Applies to Firmware Version 2387 V6.02 onwards.	

3 Axis Base Station using WindMasters and required Configuration Settings:-

1590-PK-020	WindMaster
1561-PK-020	WindMaster Pro
1590-PK-050	WindMaster Pipe Mount
1590-PK-130	WindMaster RA
M4,U1,O1,L1,P1,B4,H2,NQ,E1,T1,S1,C2,A4,I1,J1,V1,X1,G0,K0,F1 1,F2 0,F3 1	

2.1.4. Radiation Shield



A MetSpec Base Station Multi-Plate Radiation Shield provides excellent protection to the Rotronics temperature and relative humidity sensor, shielding the probe from unwanted errors, especially from secondary upward reflecting solar radiation and/or wind blown precipitation/airborne contaminants. The special shield plate geometry, with its double louvre design, provides excellent response time performance of quick ambient temperature changes while still working effectively as a baffle to stop larger contaminants such as salt or dirt from reaching the Rotronics probe. Due to the increased protection offered to the Rotronics probe by the MetSpec shield, the maintenance cycle can be extended. The shield benefits from very robust material choice and extremely high UV protection requiring no maintenance. A further benefit of the MetSpec shield design is that the measured temperature is now even closer to reference temperature measurements made using artificially aspirated motors without the drawbacks of such systems (power and the maintenance of moving parts).

2.1.5. Temperature, Relative Humidity and Dewpoint

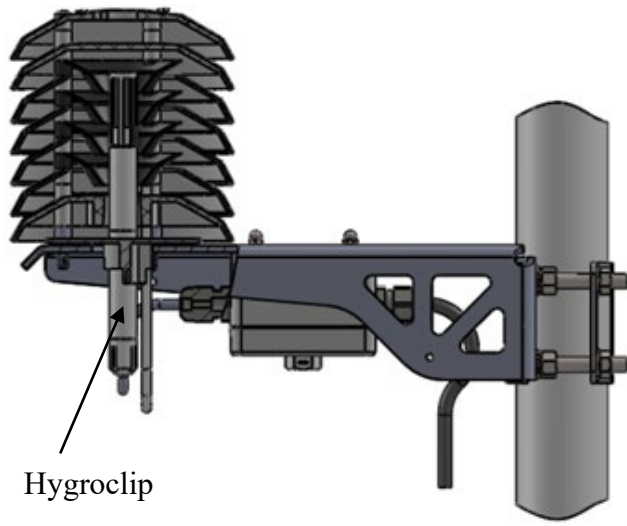

The MetPak Base Station MetSpec shield contains a Rotronic Hygroclip module. It is a complete instrument, with integrated temperature compensation. Calibration data is maintained within the integrated electronics. It provides digital output signals for Relative Humidity, Temperature and Dewpoint.

2.1.6. Barometric Pressure

Barometric pressure output is provided by a solid-state device fitted on to the circuit board in the MetPak Base Station Unit Hub box. Vent to atmosphere is via a Gore-Tex type filter which also protects the pressure sensor from the effects of wind and rain.

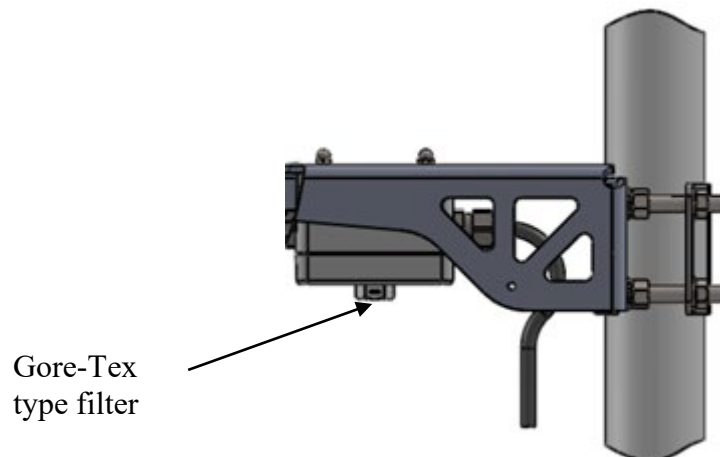

2.1.7. Precipitation (Digital Input 1).

MetPak Pro Base Station:–

Rainfall can be measured by the well-proven tipping bucket method. Rain is collected by a funnel and is passed to one of the two buckets situated at either end of a short balance arm. The balance arm tips when the first bucket is full, emptying this bucket and positioning the second bucket under the funnel. The tipping process repeats indefinitely as long as the rain continues to fall, with each tip corresponding to a fixed quantity of rainfall; at each tip the moving arm forces a magnet past a reed switch, causing contact to be made for a few milliseconds.

The Digital input (DIG1), detects when two dedicated terminals are short circuited (less than 1k ohm). Rain levels are provided by reading the number of switch closures taking place over each output rate time period (default one reading per second). Then multiplying this number by the Rain Gauge count figure set using MetSet (e.g. 0.2mm per switch closure) and outputting the result in the data string.

2.1.8 PRT Temperature (PRT Input)

An external 2 or 4 wire PT100 device can be connected to a MetPak Pro Base Station to provide an additional remote temperature measurement.

2.1.9 Analogue Sensor 1

An external remote analogue sensor, 0-5v/4-20mA output, can be connected to a MetPak Pro Base Station AN1 input.

2.1.10 Analogue Sensor 2

An external remote analogue sensor, 0-5v/4-20mA output, can be connected to MetPak Pro Base Station AN2 input.

2.1.11 Status of MetPak Sensors

Outputs the MetPak Base Station Sensors Status Code (see para 8.3.2).

2.1.12 Supply Voltage

The DC Supply voltage measured at the MetPak Base Station unit is output in the Base Station Digital Data Output string.

2.2. MetPak Base Station Range default ASCII Output Summary

MetPak 2 Axis Base Station Default Data String

Node, Relative Wind Direction, Relative Wind Speed, Pressure, Humidity, Temperature, Dewpoint, Supply Voltage, Status, Checksum.

STX>Q,170,000.08,1019.5,035.0,+024.7,+008.3,+04.9,00,<ETX>55 & (CR,LF)

MetPak 3 Axis Base Station Default Data String

Node, Relative Wind Direction, Relative Wind Speed, W Axis, Pressure, Humidity, Temperature, Dewpoint, Supply Voltage, Status, Checksum.

STX>Q,170,000.08,+000.02, 1019.5,035.0,+024.7,+008.3,+04.9,00,<ETX>55 & (CR,LF)

MetPak Pro 2 Axis Base Station Default Data String

Node, Relative Wind Direction, Relative Wind Speed, Pressure, Humidity, Temperature, Dewpoint, PRT, Analogue Input 1, Analogue Input 2, Digital Input 1, Supply Voltage, Status, Checksum.

<STX>Q,249,000.01,1017.3,049.2,+021.4,+010.3,+040.45,+000.06,+000.04,0000.000,+11.6,00,<ETX>7C & (CR,LF)

MetPak Pro 3 Axis Base Station Default Data String

Node, Relative Wind Direction, Relative Wind Speed, W Axis, Pressure, Humidity, Temperature, Dewpoint, PRT, Analogue Input 1, Analogue Input 2, Digital Input 1, Supply Voltage, Status, Checksum.

<STX>Q,249,000.01,+000.02,1017.3,049.2,+021.4,+010.3,+040.45,+000.06,+000.04,0000.000,+11.6,00,<ETX>7C & (CR,LF)

3. TECHNICAL SPECIFICATION

Wind Measurement	
Parameters	Polar Wind Speed & Direction (2 axis sensor) plus Vertical axis (3 axis sensor) or U and V Vectors (2 axis sensor) or U, V and W vectors for 3 axis sensor.
Units of Measurement	m/s, knots, mph, kph, ft/min
Wind Speed - Refer to Supplied Anemometer Manual for full details	
Range	0-45m/s WindMaster 0-60m/s WindSonic/WindSonic M 0-65m/s WindMaster Pro 0-70m/s WindObserver 70 0-75ms WindSonic 75/WindObserver 75 0-90m/s WindObserver 90
Accuracy	± 2% RMS @12m/s
Resolution	0.01m/s
Threshold	0.01m/s
Wind Direction	
Range	0-359 Degrees – No dead band
Accuracy	± 2° RMS @12 m/s
Resolution	1°
Air Temperature (Hygroclip)	
Type	Pt 100 1/3 Class B
Range	-35°C to +70°C
Accuracy	±0.1°C
Resolution	0.1°C
Units of Measure	°C or °F
Relative Humidity (Hygroclip)	
Range	0-100%
Accuracy	±0.8% @ 23°C
Resolution	1%
Units of Measure	% RH
Dew Point	
Resolution	0.1°C
Accuracy	±0.15°C (23°C ambient temperature @ 20°C dew point)
Units of Measure	°C or °F
Barometric Pressure	
Range	600 to 1100hPa
Accuracy	±0.5hPa
Resolution	0.1hPa
Units of Measure	hPa, mbar, mmHg, InHg
Compensated for Temperature dependency -20°C to +70°C	

Inputs - MetPak Pro Base Station.	
Analogue 1 (AN1)	0 to 5V or 4 to 20mA powered or Analogue Sensor Powered.
Analogue 2 (AN2)	0 to 5V or 4 to 20mA powered or Analogue Sensor Powered.
Analogue Input A-D Conversion	12 bit resolution with an accuracy of $\pm 0.1\%$ of reading, +35uV offset (voltage inputs) or $\pm 0.5\mu\text{A}$ (current inputs).
Analogue Input Impedance	Input impedance for 0-5v input is 330 k ohm. Input impedance for 4-20mA input is 47 ohms.
PRT	4 wire PRT, Pt100 conforms to IEC 60751
Digital Input (DIG1) Rain Gauge	Contact Closure input (tipping bucket rain gauge) capable of capturing events up to 10Hz
Digital Input	Capable of detecting an event with a duration of greater than 1.4mS.
Digital Input	Capable of detecting a space between events (i.e. terminals open-circuit) with a duration of greater than 11mS.
Digital Input	Capable of reading a switch contact closure providing the total Digital Switch contact resistance (contact and cabling) is less than 1k ohm.

Outputs	
Digital Outputs	RS232, RS422, *RS485 (*2 wire point to point) or SDI-12. (RS232 point to point and RS485 2 wire networkable – MODBUS RTU/ASCII)
Baud Rates	1200 (SDI-12), 4800-57600 (ASCII RS232, RS422, *RS485) 9600-19200 (MODBUS RTU/ASCII)
Protocols	ASCII, SDI-12 V1.3, NMEA 0183 (MetPak only) or MODBUS RTU/ASCII
Data Output	1 reading per second (1 Hz), 1 reading per 2 seconds, 1 reading per 4 seconds or Polled Mode
MetPak Status	Status codes provided within the data message string
* RS485 2 wire point to point only.	

Power Supply	
Input voltage (RS232, RS422, RS485)	12v to 30v dc
Current at 12v	Default setting (first value is Base Station current) 15mA MetPak Base Station Current 23mA MetPak RG Base Station Current 23mA MetPak Pro Base Station Current + 9mA at 12v with WindSonic +13mA at 12v dc with WindSonic 75 + 9mA at 12v WindSonic M (plus heater power) + 50mA at 12v WindObserver 70/75/90 (plus Heater power) + 55mA at 12v WindMaster/WindMaster Pro
Input Voltage SDI-12	9.6v to 16v dc (12v nominal)

Current	30mA MetPak Base Station Current 35mA MetPak Pro Base Station Current + 9mA at 12v with WindSonic +13mA at 12v dc with WindSonic 75 + 9mA at 12v WindSonic M (plus heater power) + 50mA at 12v WindObserver 70/75/90 (plus Heater power) SDI-12 not applicable with WindMaster/Pro
---------	--

Environmental MetPak Base Station Range

Protection Class	IP65
EMC	BS EN 61326
Operating Temperature	-35°C to +70°C
Storage Temperature	-40°C to +80°C
Humidity	0-100%
RoHS Compliant	Yes

Mechanical MetPak Base Station Range

External Construction	UV Stabilised white thermoplastic (MetSpec shield and Hydroclip Mountings) and anodized Aluminium bracket
Fittings	Stainless Steel 316 bracket fittings supplied for clamping to a vertical pipe diameter of diameter 30mm to 58mm.
Overall Dimensions MetPak Base Station MetPak Pro Base Station	201mmx287mmx129mm (excluding bracket clamp) 201mmx287mmx129mm (excluding bracket clamp)
Weight MetPak Base Station MetPak Pro Base Station	1.7kg (including bracket and 10M cable) 1.7kg (including bracket and 10M cable)

Software

MetSet Configuration	Free PC Software providing the means of configuration of the Base Station Unit.
MetView	Free PC Software providing the means of viewing Base Station data and providing a basic logging facility.

4. PRE-INSTALLATION

4.1. Equipment supplied

- 1723-xA-x-xxx 2 Axis MetPak Base Station Variant unit with a 10 metre cable from the Hub box to connect to a Gill 2 axis Anemometer.
- Or
- 1723-xC-x-xxx 3 Axis MetPak Base Station Variant unit with a 10 Metre cable from the Hub box to connect to a Gill 3 axis WindMaster range Anemometer.
- and A Gill anemometer either as part of the Base Station part structure or ordered separately.
- and 8 way connector inside the hub box for power and communication.
- and Mounting bracket plate/nuts and bolts in a box.
- and Product Test Report.

4.1.1. Optional Extras:

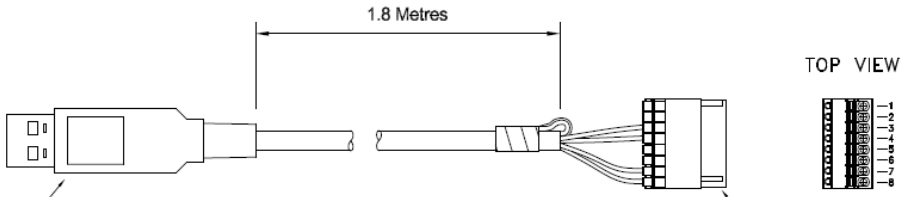
Item	Part Number
Barometric Pressure Hub Box Gore-Tex filter spares kit	1723-PK-024
Hygroclip Temperature and Humidity Filter Replacement Kit (two filters)	1723-PK-027
Hygroclip HC2A-S3-GI	037-06762
Heater Interface Box	1723-PK-099
Rain Gauge. ARG314 Tipping bucket (no cable attached)	1723-PK-077
Junction Box with internal terminating pcb (for MetPak Pro).	1723-PK-201
Terminating pcb (used in Junction box) for MetPak Pro.	1723-PK-202
Pack of 4 brackets for Pole Mounting the Junction Box for MetPak Pro	1723-PK-203
Pack of 4 feet for Panel Mounting the Junction Box for MetPak Pro.	1723-PK-204
<p>MetPak Range 1.8 Metre RS232 to USB converter including 5v dc power and communication configuration cable (8 way MetPak hub box connector fitted one end and USB connector at the other end).</p> 	1723-10-051

4.2. Base Station Anemometer 10 Metre Cable Assembly.

Base Station variants come with an integral 10 Metre, Belden 8104 cable (7 wires and a screen) fitted to the hub box connector J4, (RS422 interface).

The 10 Metre cable is terminated in pre-fitted connector contacts for installing into a WindSonic Option 2/3/M with 9 way Clipper Connector or WindMaster/WindMaster Pro 31 way Clipper Connector (connectors supplied with the Wind Sensor).

This Anemometer RS422 cable can be extended using twisted pair screened cable if required within the bounds of RS422 communication limits and ensuring the anemometer receives its minimum supply voltage.

The cable provides communication and DC power to the Wind Sensor. Care must be taken not to short out contacts should the base station be powered before a connector is fitted.

If used with a WindObserver or WindSonic M with Analogue Outputs the 10 Metre cable contact pins will need to be cut off and wire stripped/soldered for use with their respective connector contacts or termination into the optional Heater Power Interface Box.

If cutting off existing pre-fitted contacts or shortening the 10 Metre cable to a required length for use with a WindObserver or WindSonic M with analogue outputs, strip and prepare as follows:-

1. Trim back the screened cable outer PVC sheath to 50mm.
2. Trim back the braid and drain wire to 20mm from the outer sheath.
3. Separate braid and drain wire from the foil and cores. Twist braid and drain wires together.
4. Trim the twisted braid and drain wire to 15mm from the outer sheath and tin ends 5mm.
5. Cut the foil and White/Green wire (retain) back to within 5mm of the outer sheath.
6. Strip and tin one end of the White/Green wire removed to 5mm.
7. Position the White/Green wire to the twisted braid and drain wire and solder.
8. Insulate the White/Green/braid/drain wire joint.
9. Strip back the all connection wires by 5mm and tin solder.
10. Solder the contact pins supplied with the connector to the wires.
11. **Note** that the hub box sensor connector supplies the correct strain relief for cables with an outside diameter of 6-12mm.

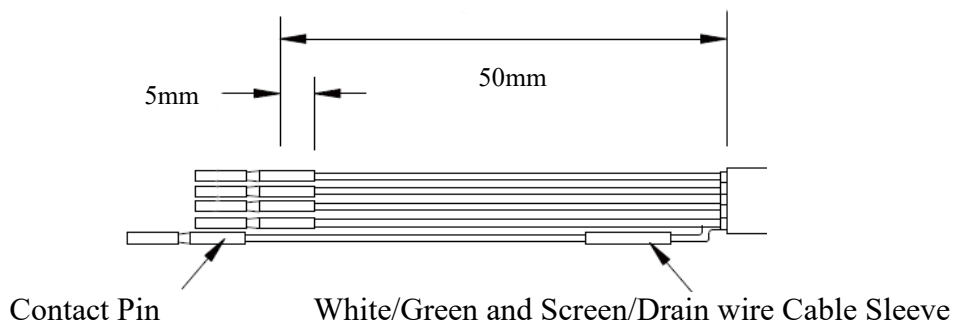

4.2.1. WindSonic and WindMaster Clipper Connector Assembly Details

Connector Assembly to the 10 Metre Lead

Route the cable through the connector parts as in direction shown below (WindSonic connector shown, the WindMaster Connector is similar).



Whilst squeezing the red retainer in the direction of ARROWS A, pull in the direction of ARROW B.



Your connector should now resemble the connector in the picture below.



Insert each contact pin until you feel a slight click. If you have inserted the contact into the incorrect hole it can be removed at this point by simply pulling it out. Please note there will be some resistance.

WindSonic (Option 2/3/M) and WindMaster/Pro RS422 10 Metre Cable Connections are as follows:-

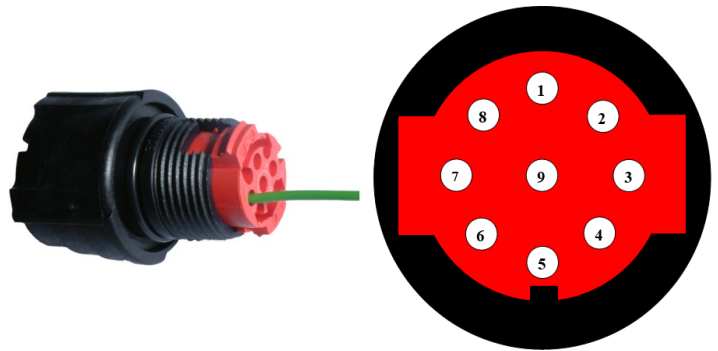
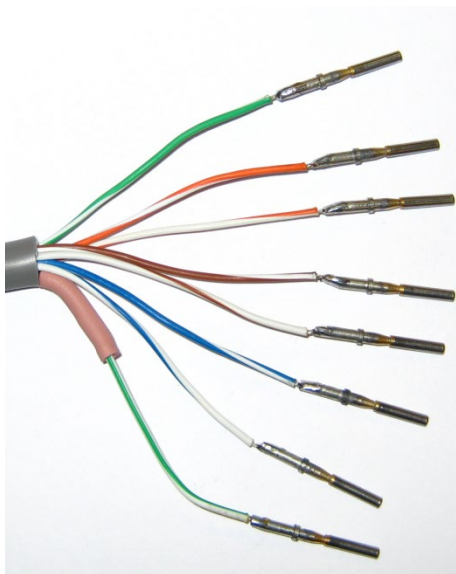

Rear View of WindSonic Connector

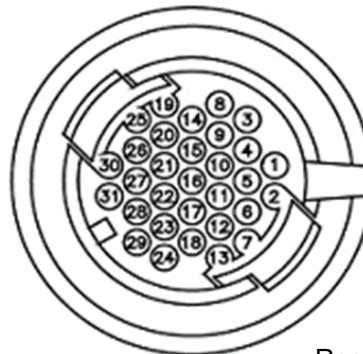

Rear View of WindMaster Connector

Base Station 10 Metre Cable	WindSonic Option 2 and 3 Connector Pin	Wind Sonic M Non Heated	WindMaster /WindMaster Pro
Green White (Sig Gnd)	1	No Connection	4
Orange White (Supply +)	2	2	11
White Orange (Supply -)	3	3	12
Brown White RS422+ input)	4	4	2
White Brown (RS422- input)	5	5	1
Blue White (RS422+ output)	6	6	5
White Blue (RS422- output)	7	7	6
White Green (Screen shield)	Cut off wire at sleeve	1	31

Continue to insert all of the contacts you require. Once all of the contacts are inserted squeeze the 2 red retainers (See Arrows A on previous page) into place. NB. The retainer can only be pushed back into place if the contacts are fully engaged.



Fit the connector to the WindSonic/WindMaster Sensor so that you can finish assembling the connector.



Screw the back shell onto the connector until it is fully in place. Please note that the final rotations can be slightly stiff.



Now screw the next part of the connector into place.



Now screw the cable-clamping nut into place.



The connector can now be removed from the WindSonic/WindMaster.

Replace the 31 way WindMaster connector sealing nut with Sealing Nut part 1723-10-109 supplied with the Base Station unit. This part allows for correct sealing around the outer surface of the wired 10 Metre cable.

NOTE: To disassemble the connector, reverse this procedure.

4.2.2. WindObserver (Non Heated units) Connector Assembly Details

Wiring between the Base Station wind sensor 10 Metre cable and a Non Heated WindObserver 19-way Cannon connector variant unit is as follows:-

Cut off the contact pins connected to the Base Station 10 Metre cable, strip and solder wires. Connect wires to the Heater Power Interface box as follows:-

Remote Base Station 10 Metre Cable	WindObserver 65/70/75/90 (Non Heated) 19 Way Connector
White/Green	Cable Screen/Drain wires
Green/White	M
Orange/White	R
White/Orange	D
Brown/White	P
White/Brown	C
Blue/White	U
White/Blue	V
No Connection	A, E and H
No Connection	B, F and G



4.2.3. WindSonic M Heated units Connector Assembly Details

WindSonic M (Heated) RS422 10 Metre Cable Connections to the Heater Power Interface Box (1723-PK-099).

Note: See also the lid of the Heater Power Interface Box for Connection Details.

Cut off the contact pins connected to the Base Station 10 Metre cable, strip and solder wires. Connect wires to the Heater Power Interface box as follows:-

Remote Base Station 10 Metre Cable	Optional Heater Power Interface Box 8 Way Terminal Block	WindSonic M (Heated) 9 Way Connector
White/Green	8	1
Green/White	7	No Connection
Orange/White	6	2
White/Orange	5	3
Brown/White	4	4
White/Brown	3	5
Blue/White	2	6

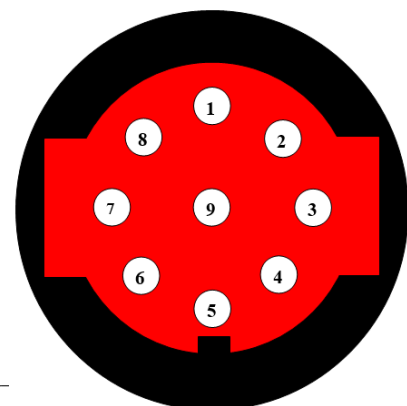

4.2.4. WindObserver Heated units Connector Assembly Details

These connection details show the use of the optional Gill Heater Interface box

WindObserver 65/70/75/90 RS422 10 Metre Cable Connections to the Heater Power Interface Box (1723-PK-099).

Note: See also the lid of the Heater Power Interface Box for Connection Details.

Cut off the contact pins connected to the MetPak Pro Base Station 10 Metre cable, strip and solder wires. Connect wires to the Heater Power Interface box as follows:-

Remote Base Station 10 Metre Cable	Heater Power Interface Box 8 Way Terminal Block	WindObserver 65/70/75/90 (Heated) 19 Way Connector
White/Green	8 or Screen Terminal Tag	Cable Screen/Drain wires
Green/White	7	M
Orange/White	6	R
White/Orange	5	D
Brown/White	4	P
White/Brown	3	C
Blue/White	2	U
White/Blue	1	V
No Connection	No Connection	A, E and H
No Connection	No Connection	B, F and G
Heater Supply +ve	3	A, E and H
Heater Supply -ve	2	B, F and G

4.3. Communication Cabling

The Base Station is supplied with a mating 8 way connector for power and communication connections.

MetPak and MetPak Pro Base Stations have five communication connection options:

USB (using the 1.8m MetPak RS232 to USB cable, Part No. 1957-10-065).

RS232.

RS422.

RS485 (two wire point to point) or networkable if using Modbus.

SDI-12.

MetPak Pro Base Station has a contact closure input and various Sensor Input connection options:

AN1 and AN2, Analogue inputs (0-5v or 4-20mA).

PRT. Platinum Resistance Thermometer Input.

It is important that the cable is appropriate for the chosen communication network. The following sections describe the recommended types and maximum lengths of cable in each case.

4.3.1 Communication and Power Cable type

Wire type: 24 AWG

Wire size: 7x32 AWG.

Cable outer diameter: 6- 8mm (to match the connector gland).

For RS422/485 operation the cable should have twisted pairs with drain wire, screened with aluminised tape, with an overall PVC sheath. Typical wire size 7/0.2mm (24 AWG).

The following table shows an example manufacturers' reference; other manufacturers' equivalents can be used.

Recommended Belden cable types

Application	No. of Pairs	24 AWG Belden Ref.
SDI-12	2	9729
Digital RS232 or RS485	3	9503
Digital RS422	4	9504
Multiple External Sensors	6	9506

4.3.2 Cable Length

The maximum cable length is dependent on the chosen communication method.

The following table shows the maximum cable lengths for the supported communication protocols at the given baud rates, using the recommended cable. If any problems of data corruption etc. are experienced, then a slower baud rate should be used. Alternatively, a higher specification cable can be tried.

Suggested maximum cable lengths for supported communication networks

Communication format	Baud rate	Max. cable length
RS232	19200	6.5M
RS422/485	19200	1000M
SDI-12	1200	90M
0-5v Analogue Input	Not Applicable	Refer to user Analogue Sensor data sheet
4-20mA Analogue Input	Not Applicable	Refer to user Analogue Sensor data sheet
Digital Switch Input	Not Applicable	Switch contact and cable resistance to be less than 1k ohm
PRT Input	Not Applicable	Refer to user PRT data sheet

4.4. Cable Connections General

Any cable wires not used should be isolated and grounded at the terminating equipment/user end.

Digital OV should be used in conjunction with RS422 TX/RX lines in order to improve noise immunity.

The Cable should be secured:-

With cable clamps or equivalent at regular intervals such that the hub box cable gland does not support the cable weight.

Away from the mounting bolts to prevent chaffing of the cable.

NOTES:-

Install appropriate strain relief support to the cable. If possible, pass the cable through the mounting pole.

The Base Station unit Hub Box cable glands contain spring loaded metal leaves that are designed to make a ground contact with cables that have an overall braid screen. Care is therefore required when inserting and removing cables through the glands to prevent damage to the metal leaves.

4.5. Earthing

To ensure correct operation and for maximum protection from lightning, a separate lightning rod system is recommended to protect the system.

You can also earth the Base Station through its mountings or by connecting a grounding cable (minimum of 6mm² copper wire) to a spare Base Station metalwork bolt hole. Clean off any paint that might prevent a good connection.

When you connect the communications cable ensure that the screen has a connection to the hub box case.

The Junction Box accessory has a plastic case, hence ensure continuity of cable screens into and out of the Junction Box using the common Earthing terminals provided in the box.

4.6. Power Supplies

Supply Voltage: 12v to 30v DC.

Average Current at 12v dc:-

MetPak Base Station	15mA plus external wind sensor current
MetPak Pro Base Station	23mA plus external wind sensor current and any Analogue 1/2 current connected units.

Base Station Units have reverse voltage polarity protection.

4.7. Power and Communication Connections

To connect Power and Communication to the MetPak Base Station Range:

Open the hub box by unfastening the four screws.

Strip the power and communication cable wires to have 8mm of exposed soldered wire.

Pass the cable through one of the gland nuts (please refer to para 4.4. Notes).

Locate the green 8 way plug in connector J5 (see below).

Connect the cable to J5 for the required communication type e.g. RS232, RS422 etc.

Attach the cable's screen wires to the Hex terminal post (see below).

After connection, securely tighten the gland nut to prevent moisture ingress.

NOTE: The MetPak Range Hub Box cable glands contain spring loaded metal leaves that are designed to make a ground contact with cables that have an overall braid screen. Care is therefore required when inserting and removing cables through the glands to prevent damage to the metal leaves.

Re-fit the hub box lid.

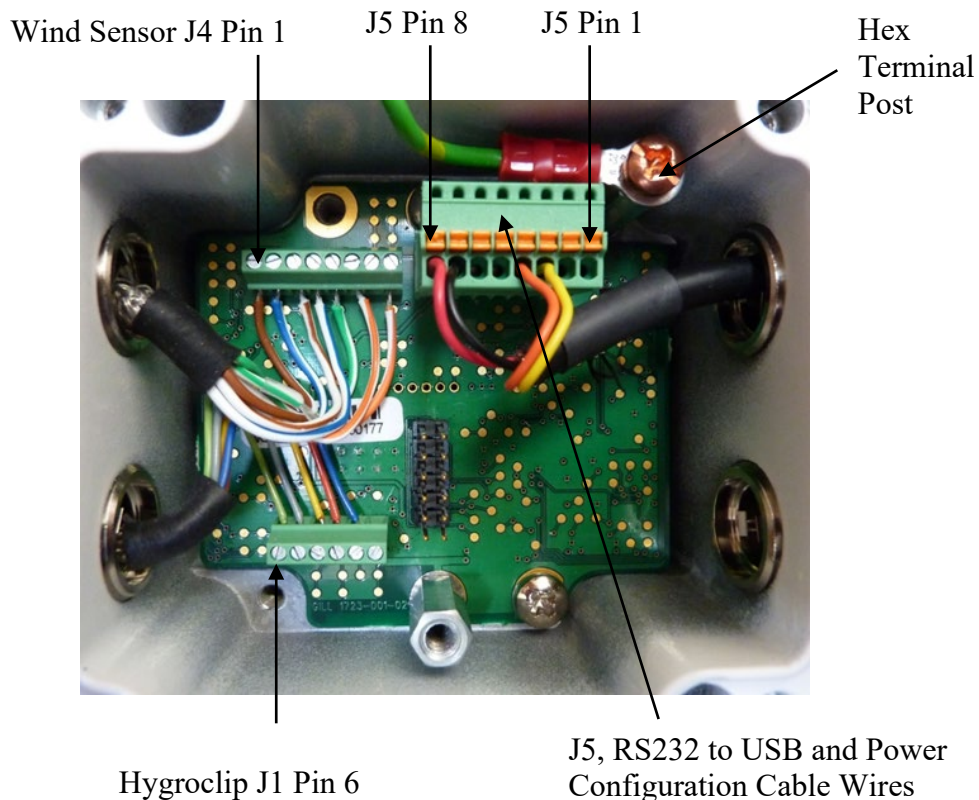

4.8. Connecting to a PC using Gill RS232 to USB Configuration Cable

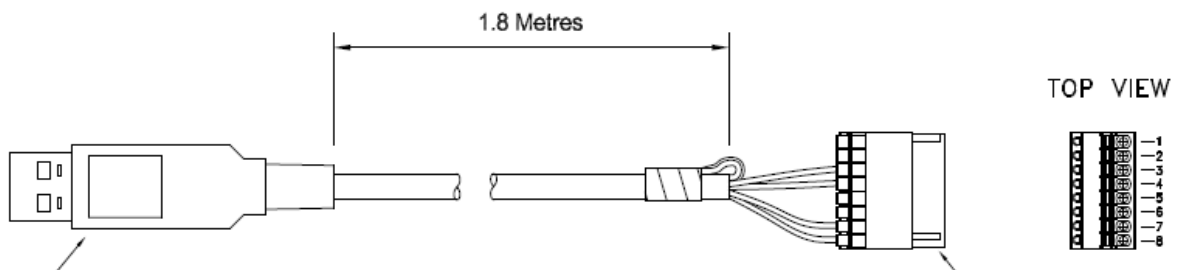
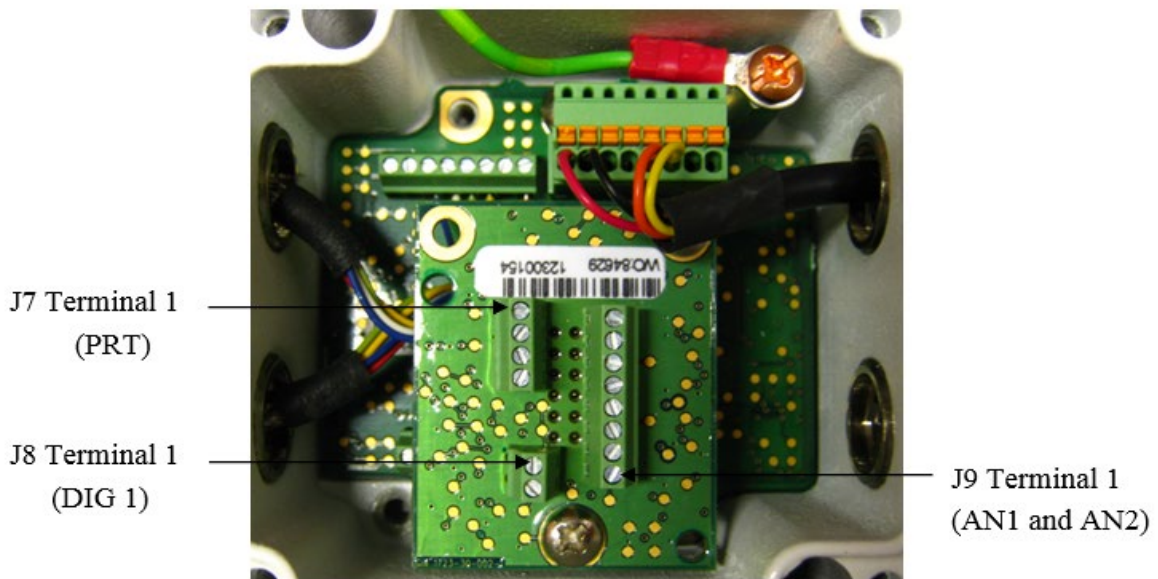

Connect MetPak to a PC USB port using the Gill Configuration Cable 1723-10-051.

J5 Pin	1	2	3	4	5	6	7	8
Colour	None	None	Yellow	Orange	None	None	Black	Red

Connection of Gill USB Cable (Part No. 1723-10-051), the J5, 8 way Phoenix connector part number is 1881383.

NOTES:-

If using the Gill Configuration RS232 to USB cable and a WindObserver or WindMaster is connected to a Base Station then the USB 5v power will not be sufficient to power them, the cable is provided only for hub box configuration.

If upon connecting the USB lead to a PC the driver is not found by the PC, then the appropriate driver to match the PC Windows version may be downloaded from:-

<http://www.ftdichip.com/Drivers/VCP.htm>

Hub Box Factory Connections

Hygroclip connections (6-way connector J1)

Connector J1	Wire Colour	Signal Name
1	-	No Connection
2	Blue	RXD from Hygroclip UART
3	Red	TXD to Hygroclip UART
4	Yellow	Analogue 0V (Not Used)
5	Grey	Supply/Signal 0V
6	Green	Supply +ve (+3.3V DC)

Wind Sensor 10 Metre cable connections (8-way connector J4)

Connector J4	Wire Colour	Signal Name
1	Brown/White	RSR422+ Anemometer Output to Hub
2	Blue/White	RS422+ Hub Output to Anemometer
3	White/Brown	RSR422- Anemometer Output to Hub
4	White/Blue	RS422- Hub Output to Anemometer
5	Green/White	Signal Ground
6	White/Orange	Supply -ve
7	-	No Connection
8	Orange White	Supply +ve

Hub Box User Connections

Power and Communications (8-way connector, J5) all units

Connector J5	Signal Name
1	SDI-12 TX/RX
2	Signal 0V
3	RS232 TX- , (or RS422/RS485 TX-) HUB to user
4	RS232 RX- , (or RS422 RX-) User to HUB
5	RS422 RX+, User to HUB
6	RS422/RS485 TX+, HUB to User
7	Supply 0v
8	Supply +ve (12v to 30v dc)

MetPak Pro Base Station PRT Sensor (4-way connector, J7)

Connector J7	Signal Name
1	PWR (PRT Power Supply +ve)
2	PRT +
3	PRT -
4	GND (PRT Power Supply Ground)

MetPak Pro Base Station Digital Switch Input, DIG1 (2-way connector, J8)

Connector J8	Signal Name
2	DIG1 (Digital Switch Contact Input)
1	GND (Ground)

MetPak Pro Base Station Analogue Sensors Input, AN1 and AN2 (8-way connector, J9)

Connector J9	Signal Name
1	VI 1 (Voltage Input 1)
2	GND (Voltage Input 1 Ground)
3	VI 2 (Voltage Input 2)
4	GND (Voltage Input 2 Ground)
5	II PWR (Current Supply for Analogue Input 1)
6	II 1 (Analogue Input 1)
7	II PWR (current Supply for Analogue Input 2)
8	II 2 (Analogue Input 2)

4.9. Connecting to a PC using RS232 (Default setting)

1. MetPak Base Station Range default factory comms setting is RS232.
2. The recommended cable length for reliable operation is limited to 6.5m (20ft).
3. For longer cable runs, we recommend use of RS422 output.

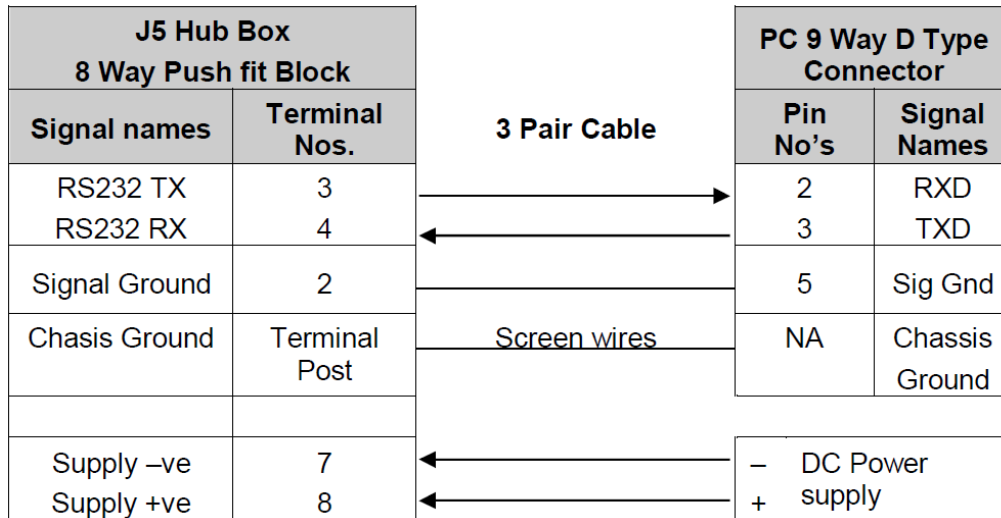

4.10. Connecting to a PC using RS422 (Not a Default Setting)

1. MetPak Base Station Range default factory comms setting is RS232.
2. To use the MetPak Range with RS422 comms use MetSet to change the COMMS Interface setting to RS422.

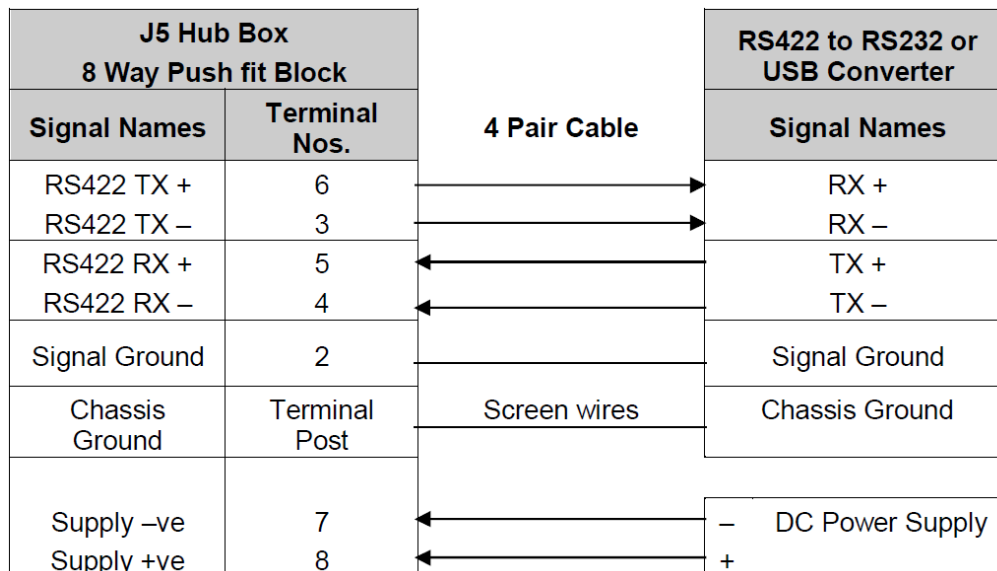

4.11. Using RS485 (2 wire point to point only, not a default setting).

1. **MetPak Base Station Range default factory comms setting is RS232.**
2. To use the MetPak Range with RS485 2 wire point to point communication use MetSet to **change the COMMS Interface setting to RS485P 2W.**
3. Use MetSet to **change the Message setting from CONT (Continuous) to POLL**, the node address letter may be changed if required.
4. **Note that it is not possible to network other devices on this 2-wire RS485 link unless the unit has been set for Modbus operation and application.**

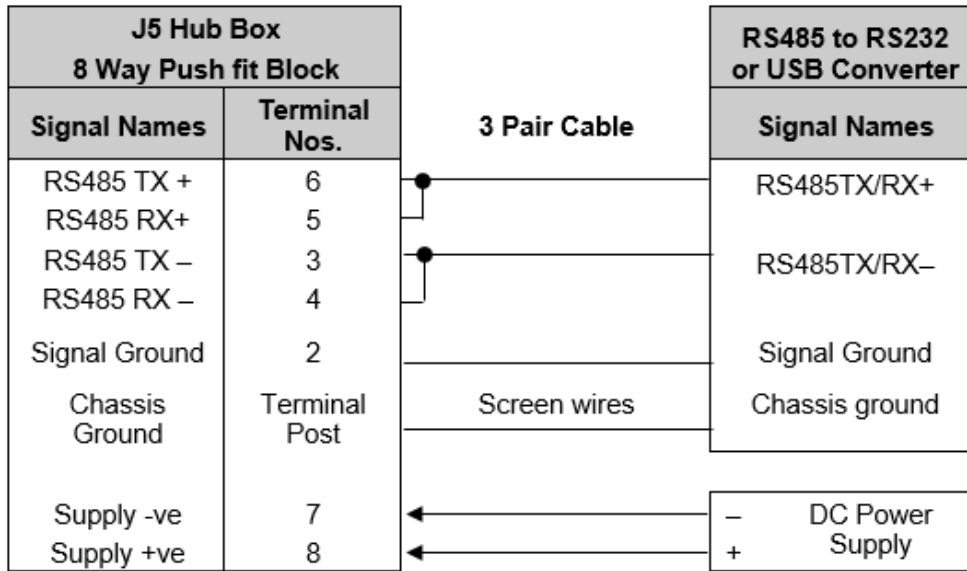

4.12. Using SDI-12 (2 wire network) not a default setting.

1. **MetPak Base Station Range default factory comms setting is RS232.**
2. Use MetSet to change the COMMS Interface setting to SDI 12.

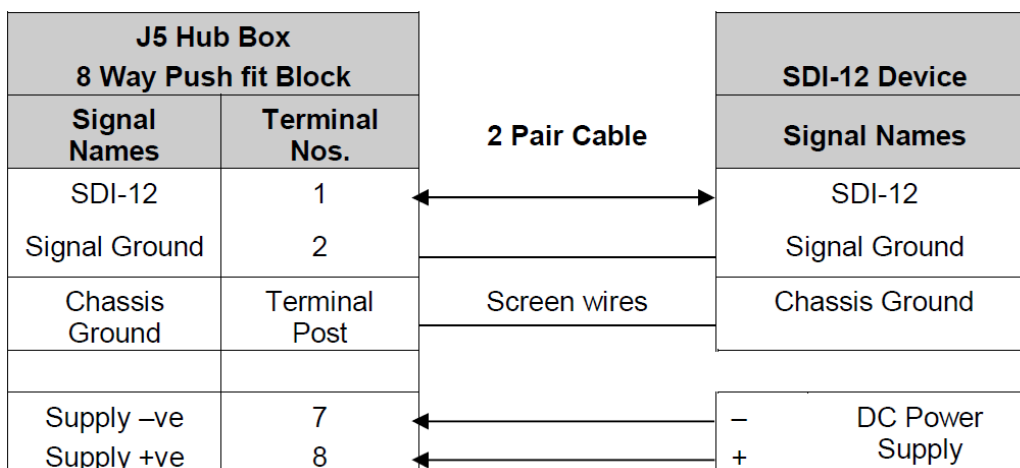

4.13. Analogue, Digital and PRT Input Connections

NOTE:

- MetPak Base Station - This section is Not Applicable.
- MetPak Pro Base Station - Analogue, Digital and PRT Input connections all applicable.

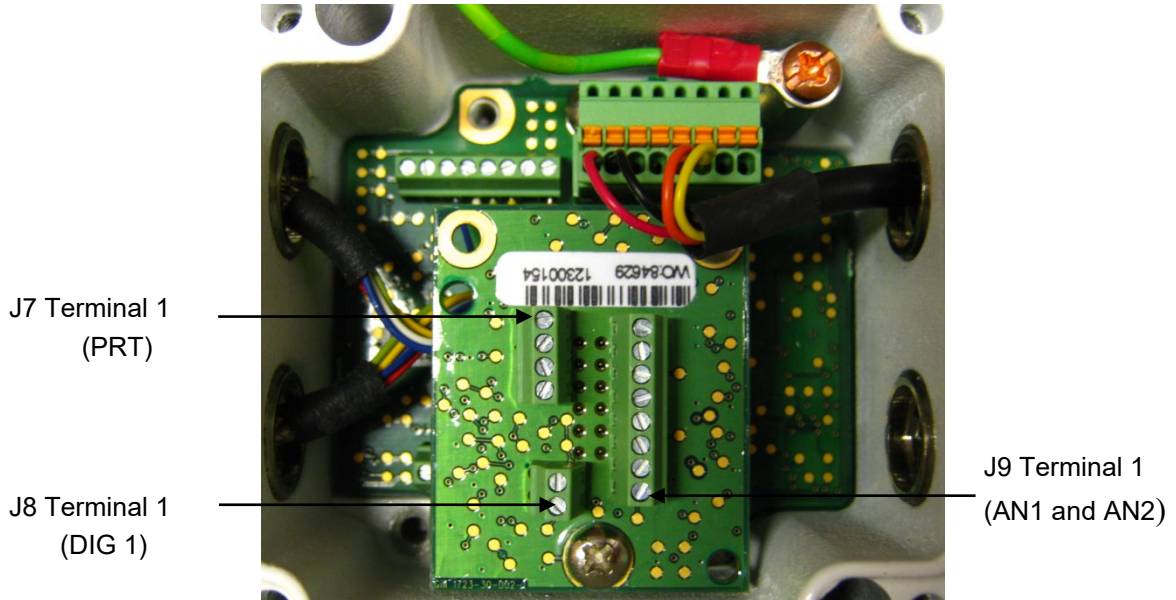

Analogue 0-5 volt Input Connections AN1 and AN2

This is not a default setting; ensure the MetPak Pro Base Station has been configured for this input requirement before wiring sensors to the Base Station.
 (See picture above for Power and Communication Connections).

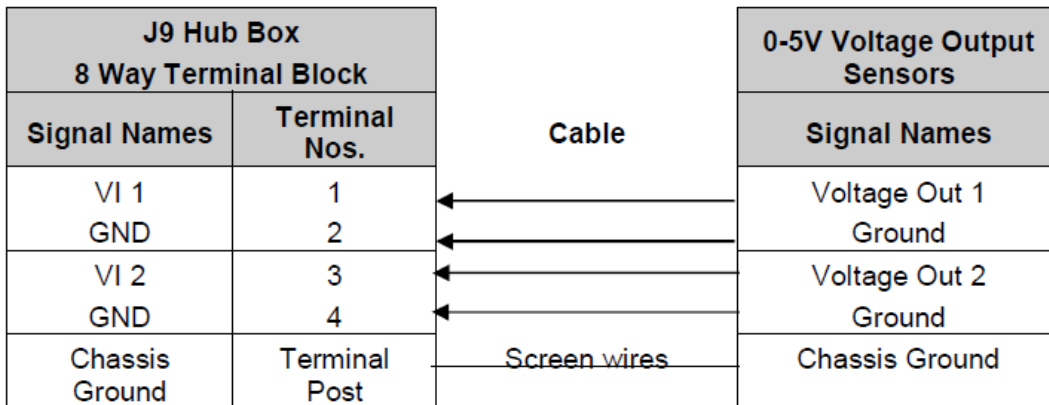

Analogue 4-20mA Input Connections (Sensor Powered) AN1 and AN2

This is not a default setting; ensure the MetPak Pro Base Station has been configured for this input requirement before wiring sensors to the Base Station.

See previous picture for Power and Communication Connections.

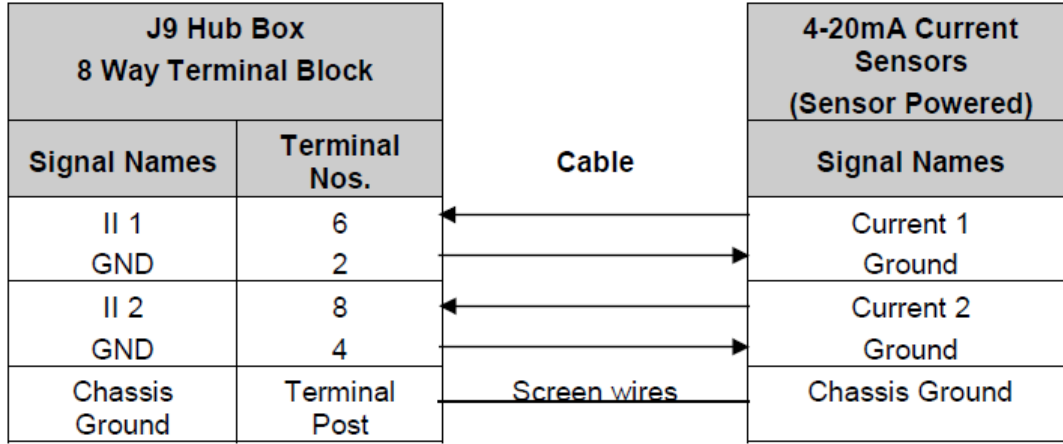

Analogue 4-20mA Input Connections (MetPak Pro Powered) AN1 and AN2

This is not a default setting; ensure the MetPak Pro Base Station has been configured for this input requirement before wiring sensors to the Base Station.

See previous picture for Power and Communication Connections.

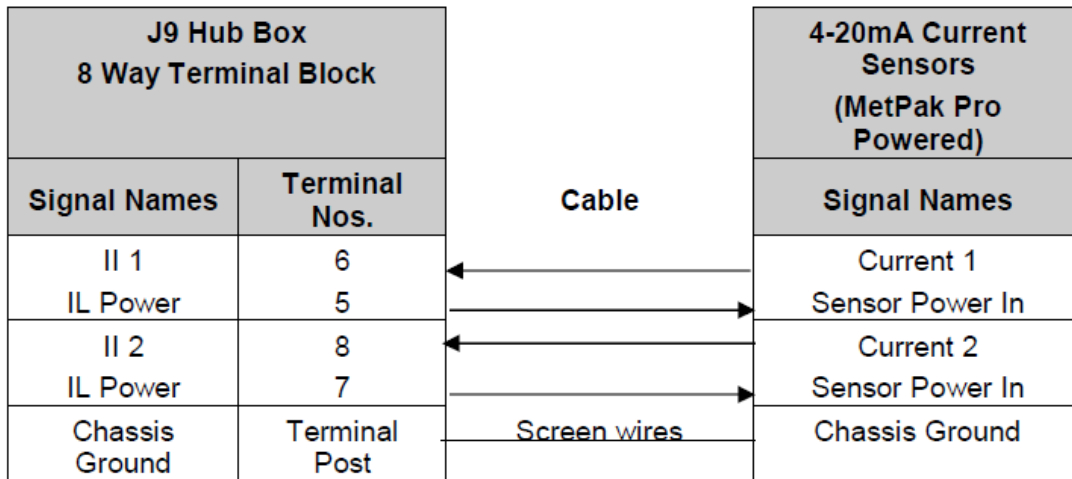

NOTE: If the input current drops below 4mA, an X will be shown in the data string instead of a valid reading. If the current rises above 20mA, an E will be shown in the data string instead of a valid reading.

Digital Switch Connection (Rain Gauge) DIG1

Ensure the MetPak Pro Base Station has been configured for this input requirement before wiring sensors to the Unit.

Digital Rain Gauge Connections

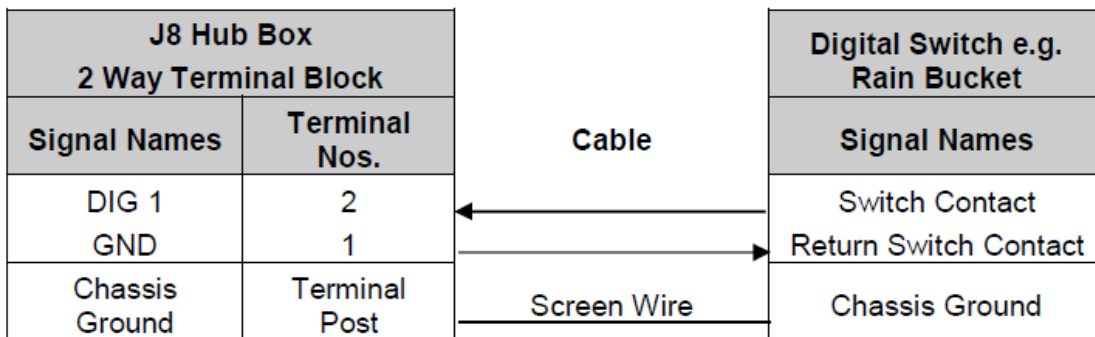
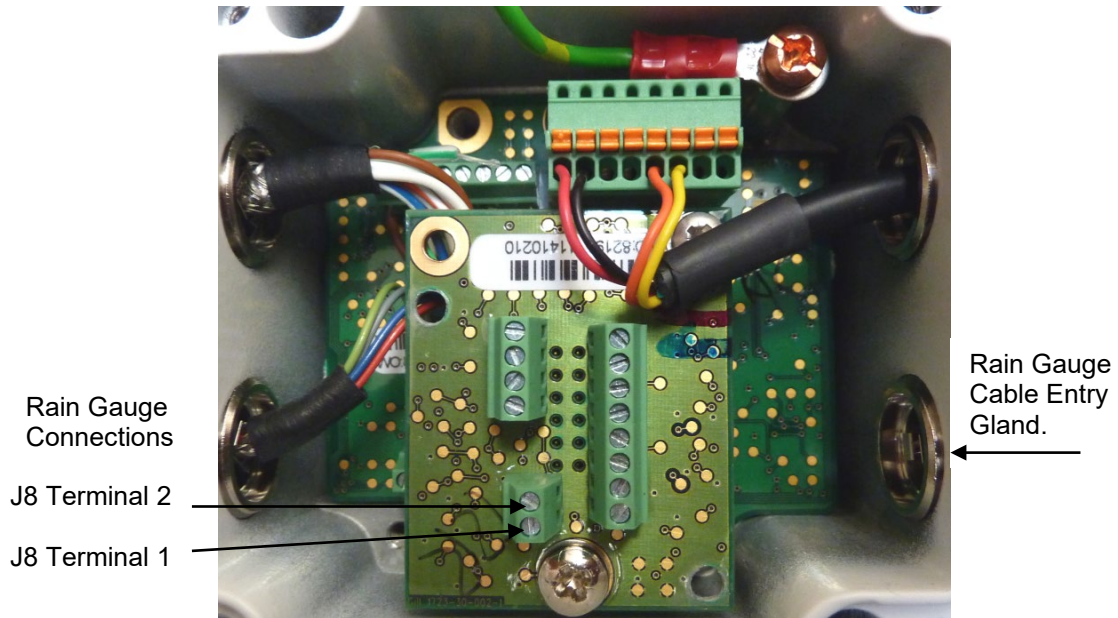

To connect a Rain gauge lead to the MetPak Pro Base Station Hub Box:-

1. Open the MetPak hub box by unfastening the four lid screws.
2. Locate connector J8.
3. Pass the cable through one of the gland nuts (see Note below).
4. Connect the cable to connections as detailed above.
5. Attach the cable's screen wire to a terminal post.
6. After connection, securely tighten the gland nut to prevent moisture ingress
7. Re-fit the hub box lid.

NOTE: The Base Station Hub Box cable glands contain spring loaded metal leaves that are designed to make a ground contact with cables that have an overall braid screen. Care is therefore required when inserting and removing cables through the glands to prevent damage to the metal leaves.

Platinum Resistance Thermometer (PRT) Input

Ensure the MetPak Pro Base Station has been configured for this input requirement before wiring sensors to the unit.

See the previous picture for Power and Communication Connections.

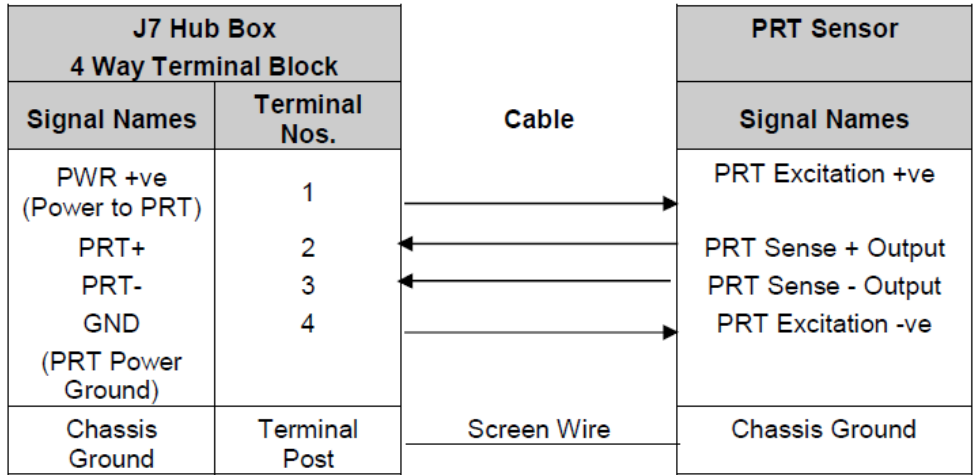

4.14. MetPak Pro Base Station Junction Box (Part 1723-PK-021)

As part of a MetPak Pro Base Station system, Gill Instruments can provide a Junction Box containing a pcb with removable terminal connectors and optional mounting hardware to provide a means of connecting external sensor and Base Station wiring at a convenient common point.

Alternatively the pcb with removable terminal connectors can be supplied as a standalone item for mounting in a customer supplied box.

Junction Box parts if required are:

- | | |
|-------------|--|
| 1723-PK-201 | Junction Box with internal terminating pcb. |
| 1723-PK-202 | Terminating pcb (to mount in customer box). |
| 1723-PK-204 | Pack of 4 feet for Panel Mounting the Junction Box. |
| 1723-PK-203 | Pack of 4 brackets for Pole Mounting the Junction Box. |

Junction Box 1723-PK-201 (containing Terminating pcb 1723-PK-202)

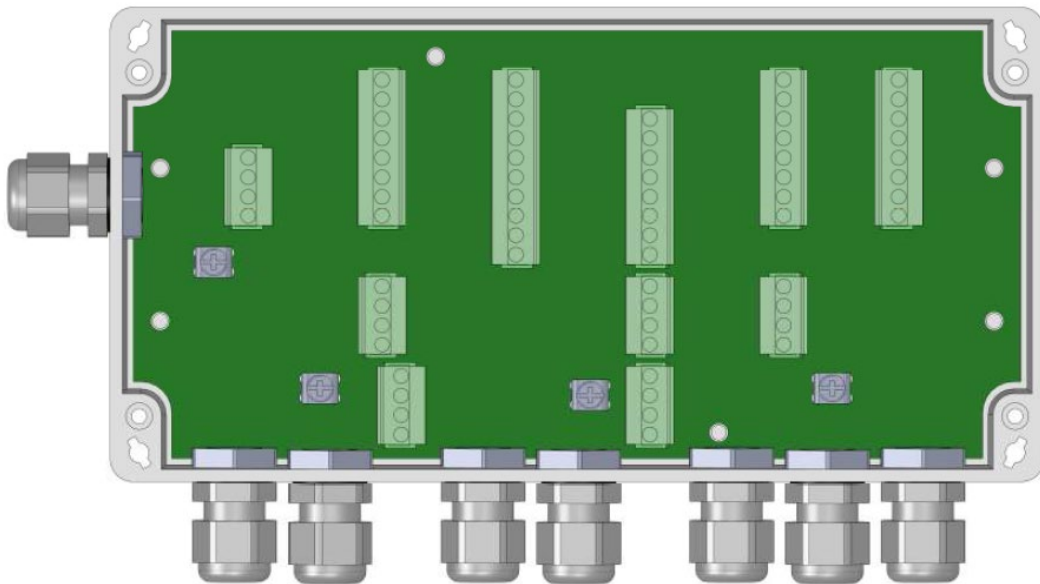

Junction Box terminating pcb circuit track layout

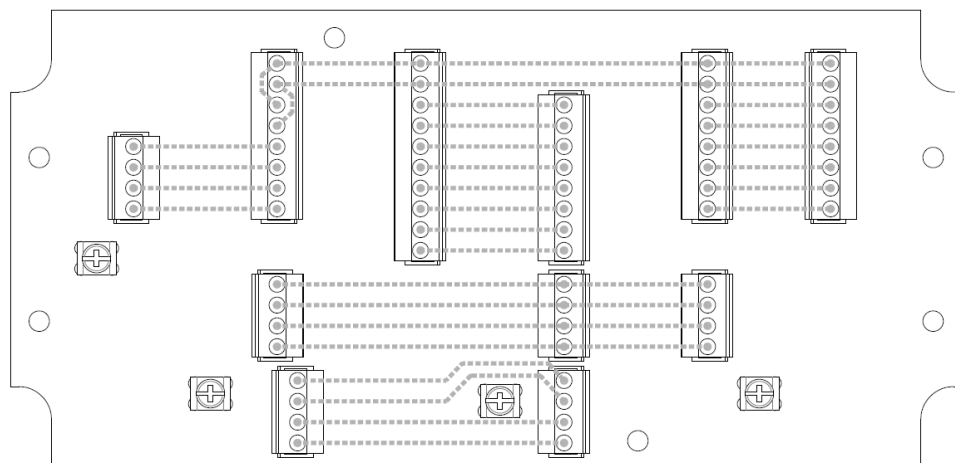

Junction Box Terminal Block Connections

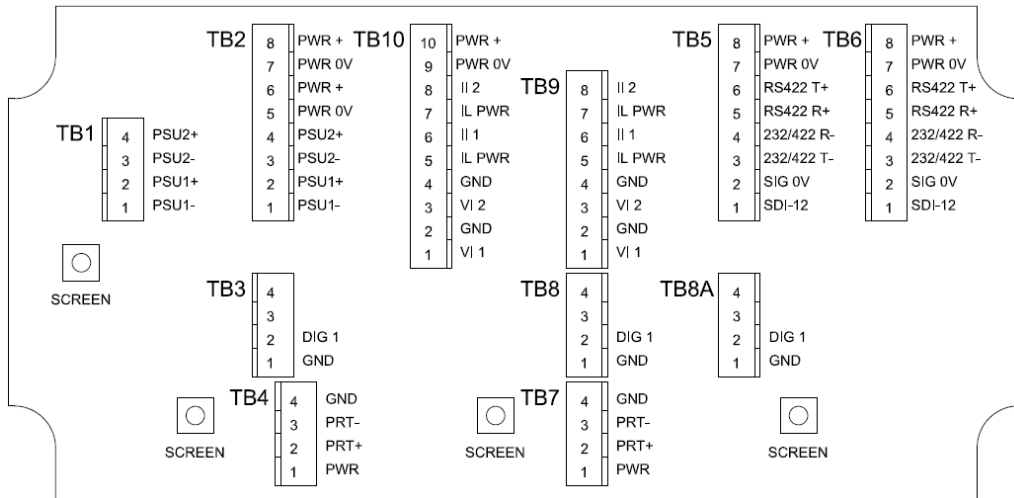

Note that the Junction box glands will accept cables with an outer diameter between 3-10mm. If a smaller diameter cable is to be used bulk out with heat shrink or suitable sleeve to ensure the gland can secure the cable and provide an environmental seal.

Communication System Connections

Only connect cables that meet the required data interface requirement (e.g. RS232 etc.).

MetPak Pro Hub Box Connector J5		Hub to Junction Box Cable	MetPak Pro Junction Box TB5	MetPak Pro Junction Box TB6	Junction Box to User Cable	User PC/Logger Interface
Signal Name	Terminal Number		Signal Name	Signal Name		Signal Name
SDI-12 TX/RX	1		SDI-12	SDI-12		SDI-12
Signal 0v	2		SIG 0v	SIG 0v		SIG 0v
RS232/422/485 TX-	3		232/422 T-	232/422 T-		232/422 R-
RS232/422 RX-	4		232/422 R-	232/422 R-		232/422 T-
RS422 RX+	5		RS422 R+	RS422 R+		422 T+
RS422/485 TX+	6		RS422 T+	RS422 T+		422 R+
Supply 0v	7		PWR 0v	PWR 0v		PWR 0v
Supply +ve	8		PWR +	PWR +		PWR +
Chassis	Terminal Tag	Screen	Screen Tag	Screen Tag	Screen	Screen Tag

• **4-20mA Current Sensor System Connections (Sensor Powered)**

MetPak Pro Hub Box Connector J9		Hub to Junction Box Cable	MetPak Pro Junction Box TB9	MetPak Pro Junction Box TB10	Junction Box to User Cable	User Current Interface
Signal Name	Terminal Number		Signal Name	Signal Name		Signal Name
II1	6		II1	II1		II1
GND	2		GND	GND		GND
II 2	8		II 2	II 2		II2
GND	4		GND	GND		GND
Chassis	Terminal Tag	Screen	Screen Tag	Screen Tag	Screen	Screen Tag

• **4-20mA Current Sensor System Connections (MetPak Pro Base Station Powered)**

MetPak Pro Hub Box Connector J9		Hub to Junction Box Cable	MetPak Pro Junction Box TB9	MetPak Pro Junction Box TB10	Junction Box to User Cable	User Current Interface
Signal Name	Terminal Number		Signal Name	Signal Name		Signal Name
II1	6		II1	II1		II1
IL PWR	5		IL PWR	IL PWR		IL Power
II 2	8		II 2	II 2		II2
IL PWR	7		IL PWR	IL PWR		IL Power
Chassis	Terminal Tag	Screen	Screen Tag	Screen Tag	Screen	Screen Tag

• **0-5 Volt Voltage Sensor System Connections**

MetPak Pro Hub Box Connector J9		Hub to Junction Box Cable	MetPak Pro Junction Box TB9	MetPak Pro Junction Box TB10	Junction Box to User Cable	User Voltage Interface
Signal Name	Terminal Number		Signal Name	Signal Name		Signal Name
VI 1	1		VI 1	VI 1		V Out 1
GND	2		GND	GND		Ground
VI 2	3		VI 2	VI 2		V Out 2
GND	4		GND	GND		Ground
Chassis	Terminal Tag	Screen	Screen Tag	Screen Tag	Screen	Screen Tag

• **Digital Switch Sensor System Connections**

MetPak Pro Hub Box Connector J8		Hub to Junction Box Cable	MetPak Pro Junction Box TB8 or TB8A	MetPak Pro Junction Box TB3	Junction Box to User Cable	User Switch Interface
Signal Name	Terminal Number		Signal Name	Signal Name		Signal Name
DIG 1	2		DIG 1	DIG 1		Contact
GND	1		GND	GND		Contact
Chassis	Terminal Tag	Screen	Screen Tag	Screen Tag	Screen	Screen Tag

• **PRT System Connections**

MetPak Pro Hub Box Connector J7		Hub to Junction Box Cable	MetPak Pro Junction Box TB7	MetPak Pro Junction Box TB4	Junction Box to User Cable	User PRT Interface
Signal Name	Terminal Number		Signal Name	Signal Name		Signal Name
PWR+ve	1		PWR+ve	PWR+ve		PRT Excitation +ve
PRT+	2		PRT+	PRT+		PRT Sense + Output
PRT-	3		PRT-	PRT-		PRT Sense - Output
PRT GND	4		GND	GND		PRT Excitation -ve
Chassis	Terminal Tag	Screen	Screen Tag	Screen Tag	Screen	Screen Tag

• **External Power Supply Connections**

User Power Supplies	User to Junction Box Cable	MetPak Pro Junction Box TB1	MetPak Pro Junction Box TB2	Cable to Sensors	User Sensor Supplies
Signal Name		Signal Name	Signal Name		Signal Name
PSU1 +ve		PSU1 +ve	PSU1 +ve		PSU1 +ve
PSU1 -ve		PSU1 -ve	PSU1 -ve		PSU1 -ve
PSU2 +ve		PSU2 +ve	PSU2 +ve		PSU2 +ve
PSU2 -ve		PSU2 -ve	PSU2 -ve		PSU2 -ve
Chassis	Screen	Screen Tag	Screen Tag	Screen	Screen Tag

4.15. Set up requirements

4.15.1. Host System:

Note: The default delivery output communication (COMMS) setting of MetPak Range Base Station units is RS232.

Use an RS232 to USB converter e.g. Gill part 1957-10-065, 1.8M configuration cable fitted with 8 way Base Station Hub Box connector and with integral 5v USB connector power for the Base Station (see Para 4.8). **Note** that if a WindObserver or WindMaster is connected to a Base Station that 5v will not be sufficient to power them, the cable is provided only for hub box configuration.

If an install driver is required for this cable it can be downloaded from:-

<http://www.ftdichip.com/FTDrivers.htm>

Or

Use an RS232 to USB adaptor or equivalent for example EasySynch part ES-U-1001-A (if not using Gill part 1723-10-051) or connect directly to an RS232 COM port.

Use a PC running Windows software up to and including Windows 10 and with an internal or external interface compatible with the output from the MetPak.

Use a Power Supply, 12V to 30Vdc at 200mA if not using the Gill Instruments Configuration cable.

Use 3 pair cable e.g. Belden 9503 (if not using Gill Part 1723-10-051), length as required if not using the Gill Instruments Configuration cable.

4.15.2. Software:

Gill MetSet Software can be used as a configuration Tool, will run on PC's with up to and including Windows 10 and can be downloaded free from:-

<http://www.gillinstruments.com/main/software.html>.

4.15.3. Bench system test

Prior to physically mounting the Base Station in its final location, we strongly recommend that a bench system test be carried out to confirm the system is configured correctly, is fully functional and electrically compatible with the selected host system and cabling (preferably utilising the final cable length). The required data format, units, output rate, and other options should also all be configured at this stage.

Connect the Base Station to a PC wired as per RS232 connections in Para 4.9.

Alternatively use a Gill configuration cable (1723-PK-051) with an 8 way connector fitted on one end and USB converter at the other if required to simplify set up between Base Station and a PC.

Open Gill MetSet software provided to read, check settings or change settings as per para 6.2.

Use MetSet View Output button to check the data string and confirm that the Status field reads 00.

4.16. Packaging

Whilst the Base Station is being moved to its installation site, the unit should be kept in its packaging. Retain the packaging for use if the unit has to be moved or returned to Gill Instruments.

5. INSTALLATION

General Installation Guidelines are as follows:-

5.1. Example System Installations

5.1.1 Non Heated Wind Sensor System

MetPak Base Station System

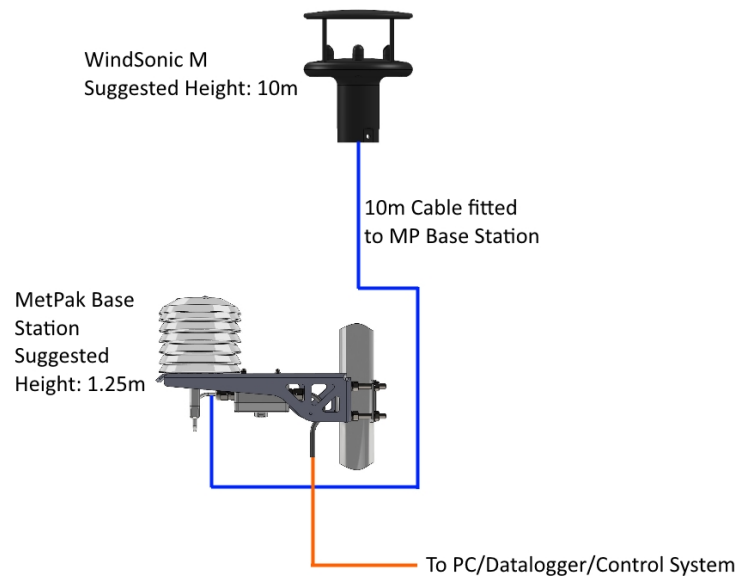

MetPak Pro Base Station system with a non-heated wind sensor system might look like the following illustration.

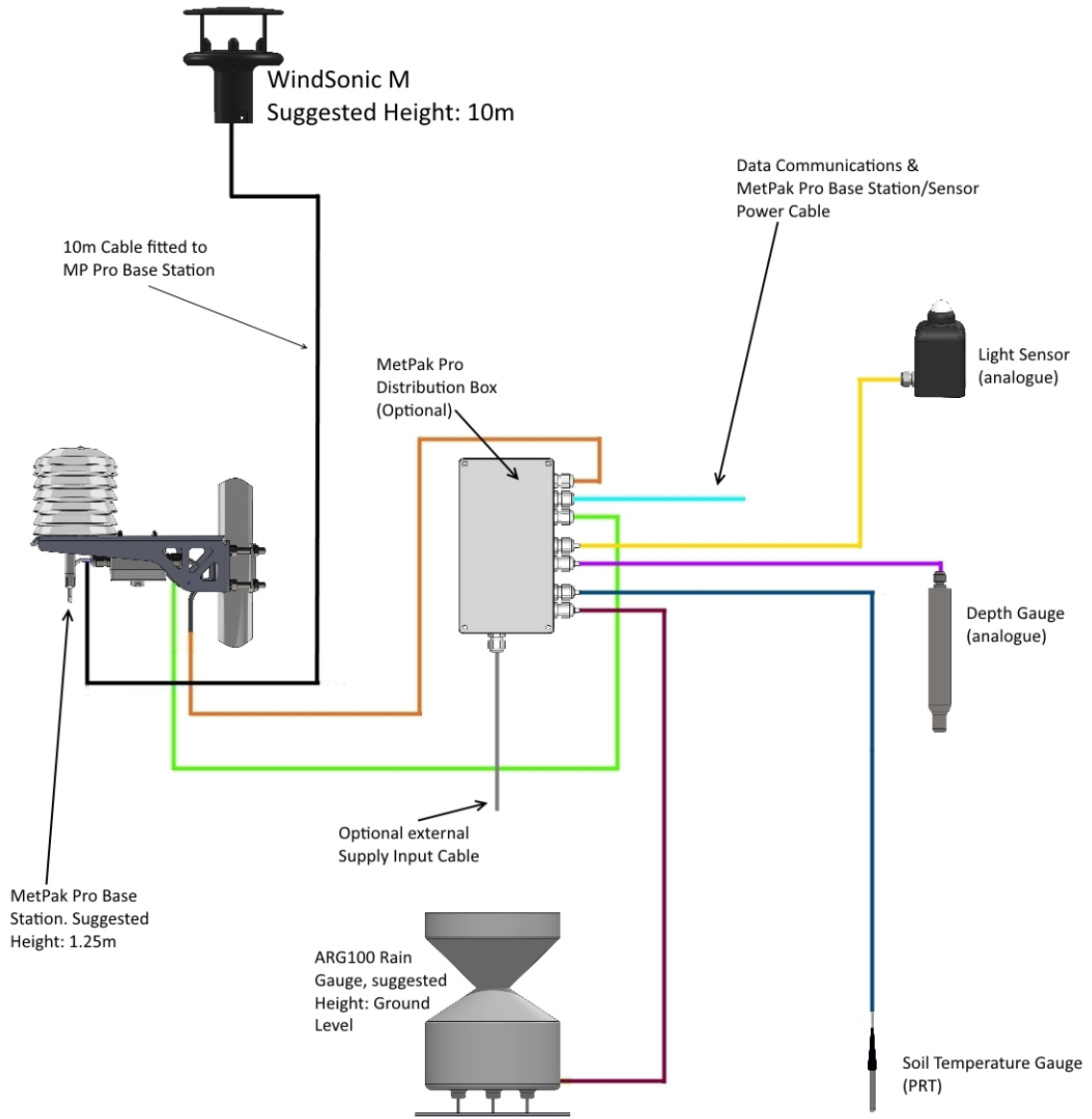

5.1.2 Heated Wind Sensor System

MetPak Base Station

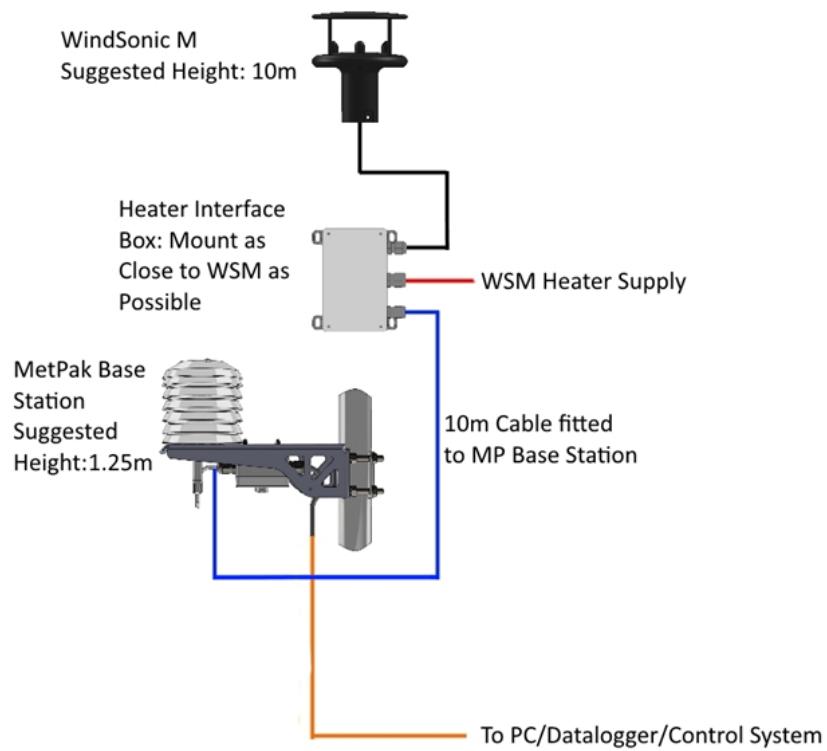

MetPak Pro Base Station example system with a heated wind sensor might look like the following illustration.

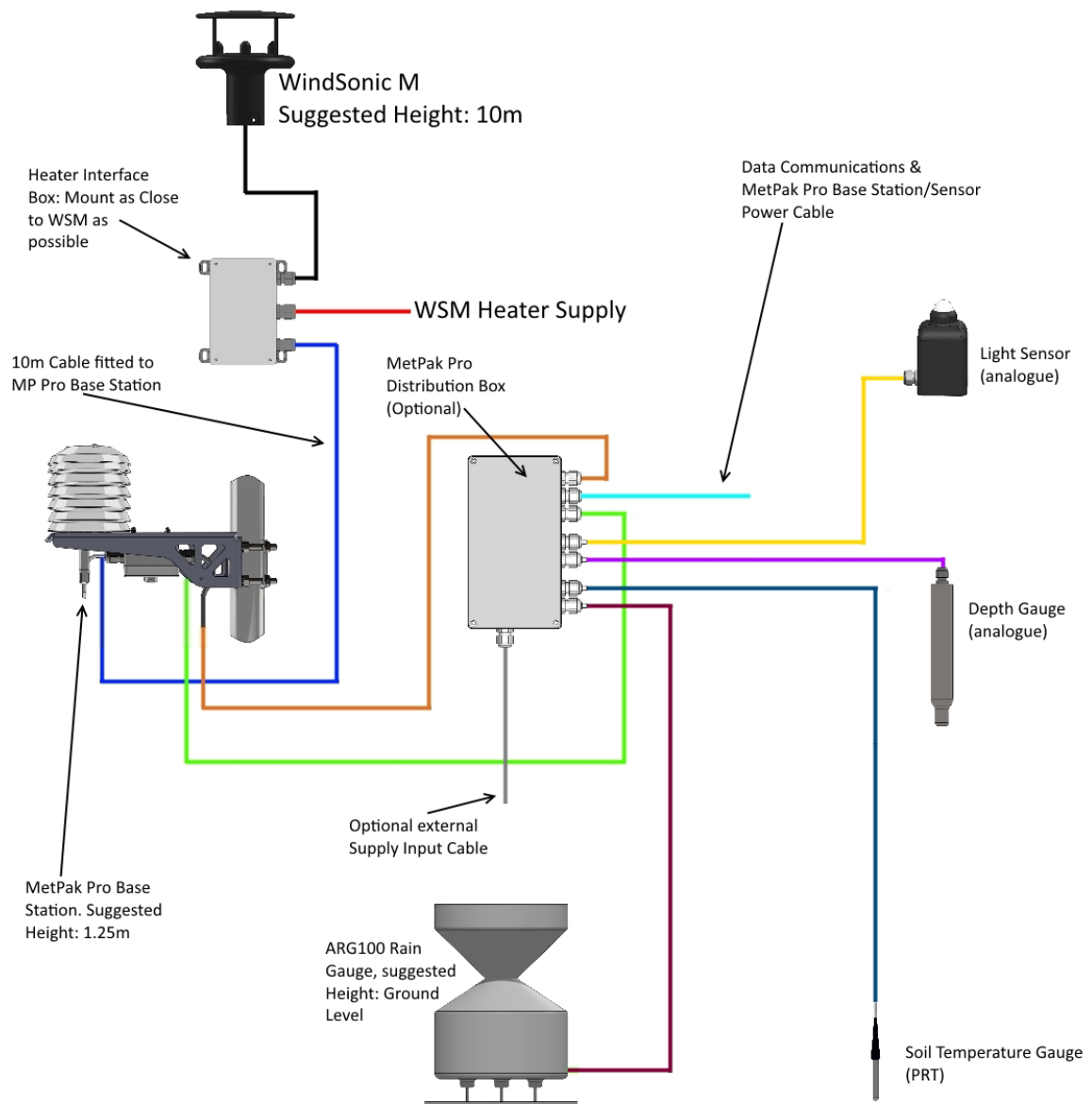

5.2. Interference

As with any sophisticated electronics, good engineering practice should be followed to ensure correct operation.

Always check the installation to ensure the Base Station and Wind sensor is not affected by other equipment operating locally, which may not conform to current standards, e.g. radio/radar transmitters, boat engines, generators etc.

Do NOT mount the Base Station Wind Sensor in close proximity of high-powered radar or radio transmitters. A site survey may be required if there is any doubt about the strength of external electrical noise.

Guidelines –

Avoid mounting in the plane of any radar scanner – a vertical separation of at least 2m should be achieved.

Radio transmitting antennas, the following minimum separations (all round) are suggested

VHF IMM – 1m

MF/HF – 5m

Satcom – 5m (avoid likely lines of sight)

Ensure the product is correctly earthed in accordance with this manual.

Use cables recommended by Gill, keeping the length below the maximum allowed. Where the cables are cut and re-connected (junction boxes, plugs and sockets) the cable screen integrity must be maintained, to prevent the EMC performance being compromised.

Earth loops should not be created – earth the system in accordance with the installation guidelines.

Ensure the power supply operates to the Base Station and Wind Sensor specification at all times.

5.3. Wind Sensor Installation

Avoid turbulence caused by surrounding structures that will affect the accuracy of the Wind Sensor such as trees, masts and buildings.

The World Meteorological Organisation makes the following recommendation:

The standard exposure of wind instruments over level open terrain is 10m above the ground. Open terrain is defined as an area where the distance between the sensor and any obstruction is at least 10 times the height of the obstruction.

If mounting on a building then theoretically the sensor should be mounted at a height of 1.5 times the height of the building.

If the sensor is to be mounted on a mast boom, part way up a tower or mast, then the boom should be at least twice as long as the minimum diameter or diagonal of the tower. The boom should be positioned on the prevailing wind side of the tower.

It is important to ensure that the Wind Sensor is mounted in a position clear of any structure, which may obstruct the airflow or induce turbulence.

Mount the Wind Sensor so as to have a clear view of prevailing winds.

The Wind Sensor should be set to point North (or to another known reference direction), using the North Pointers, which can be identified by arrows or dots or an alignment notch to aid alignment (see the illustrations in para 2.1.3).

5.4. MetPak Base Station Range Mounting and Dimensions (in mm)

MetPak Base Stations use a mounting clamp suitable for attaching to a vertical pipe with a diameter of 30-58mm. When mounting the Base Station, consider the position, orientation and alignment of the unit.

Note that the mounting pipe should first be degreased and when assembling the Base Station clamp assembly the outer clamp nuts need to be tightened evenly to a torque figure of 3 Nm.

The moving plate part of the clamp needs to be reversed for poles below 38 mm diameter.

Mounting Bracket Assembly Exploded View

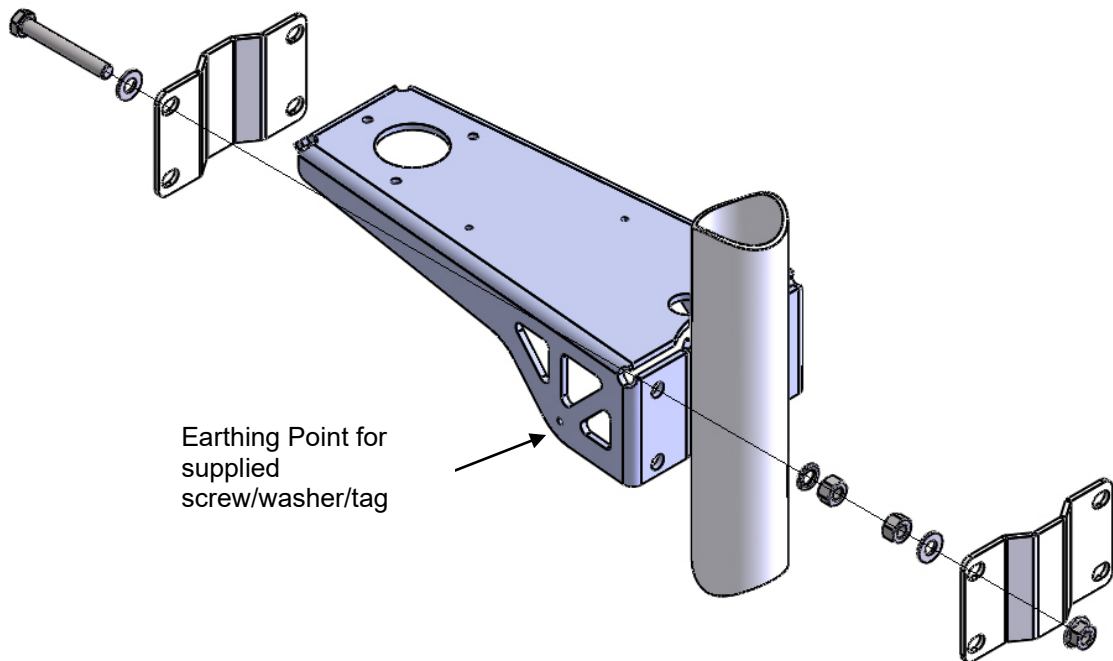

Mounting Bracket Assembled View

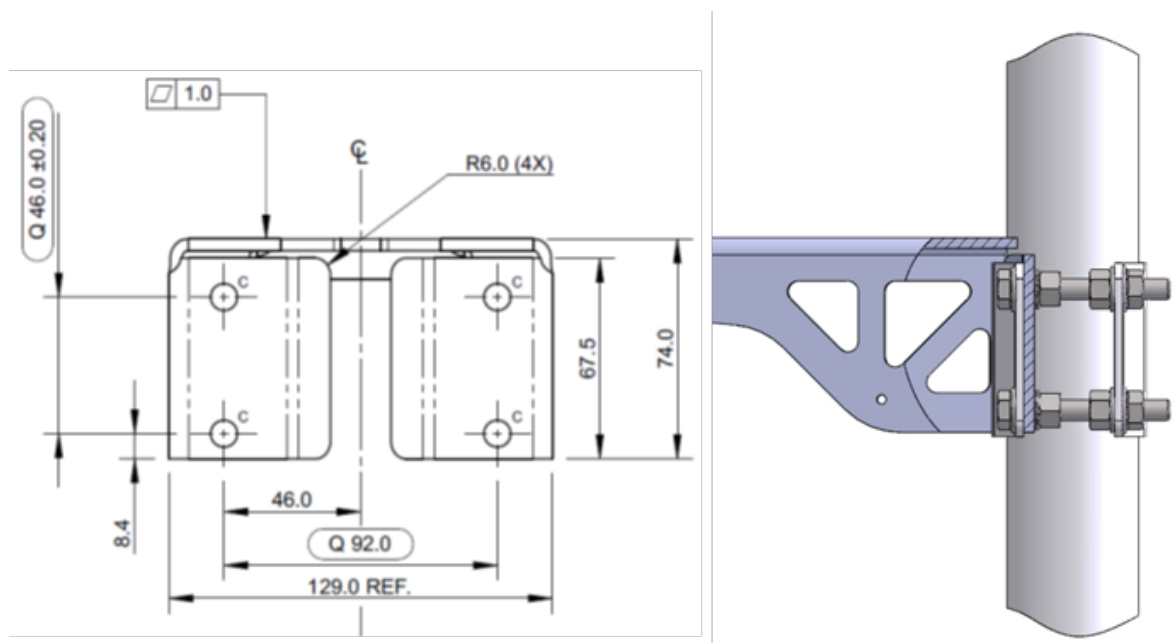

C Holes are 8.5mm diameter

MetPak Base Station Range Overall Dimensions

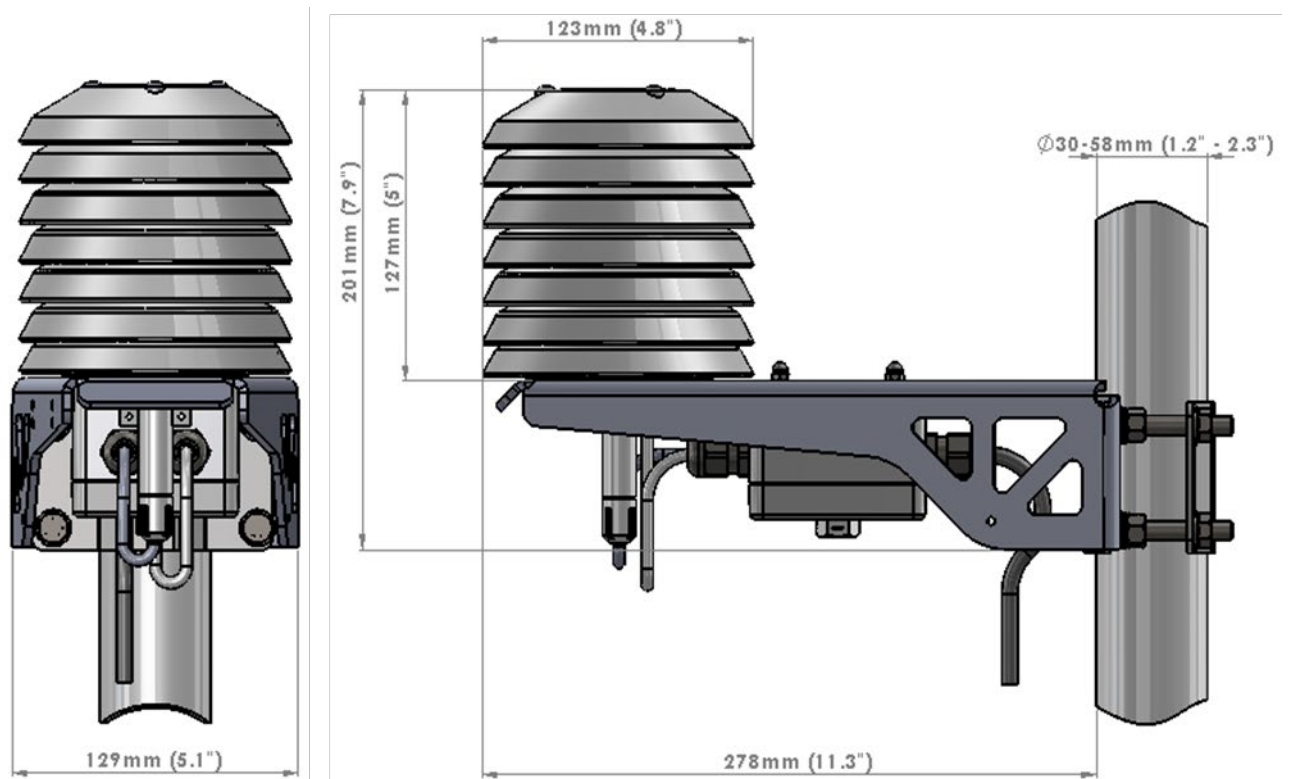

5.5. MetPak Pro Base Station Junction Box Mounting (1723-PK-021)

The optional MetPak Pro Base Station Junction Box comes with two mounting arrangement options: -

- **Junction Box Pole Mount**

Using Gill Instruments part 1723-PK-203 Pole Mount brackets set for Junction Box.

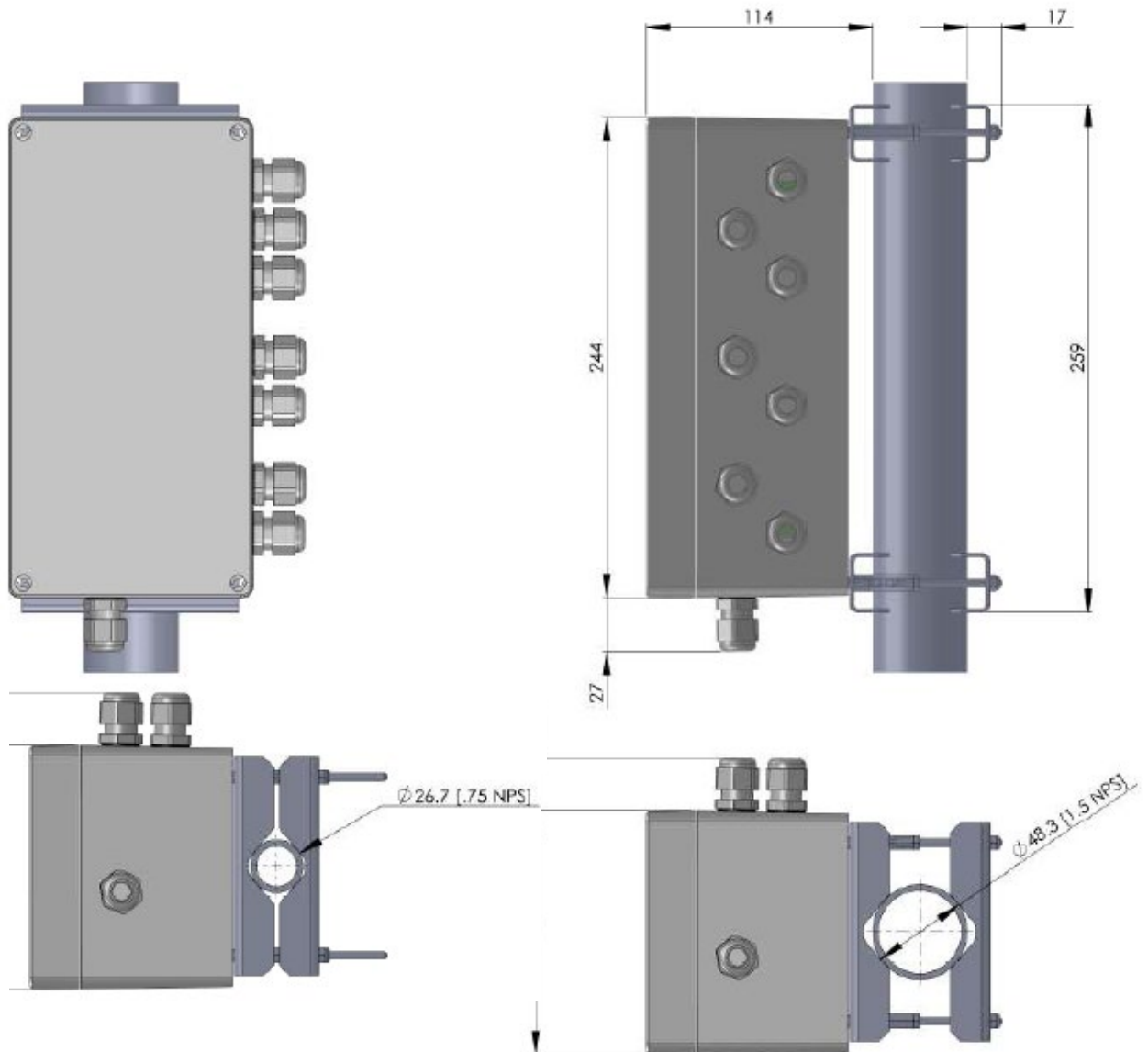

Junction Box (1723-PK-201) Panel or Wall Mount

Using Gill Instruments part 1723-PK-204 Pack of 4 feet for Wall or Panel Mounting the Junction Box.

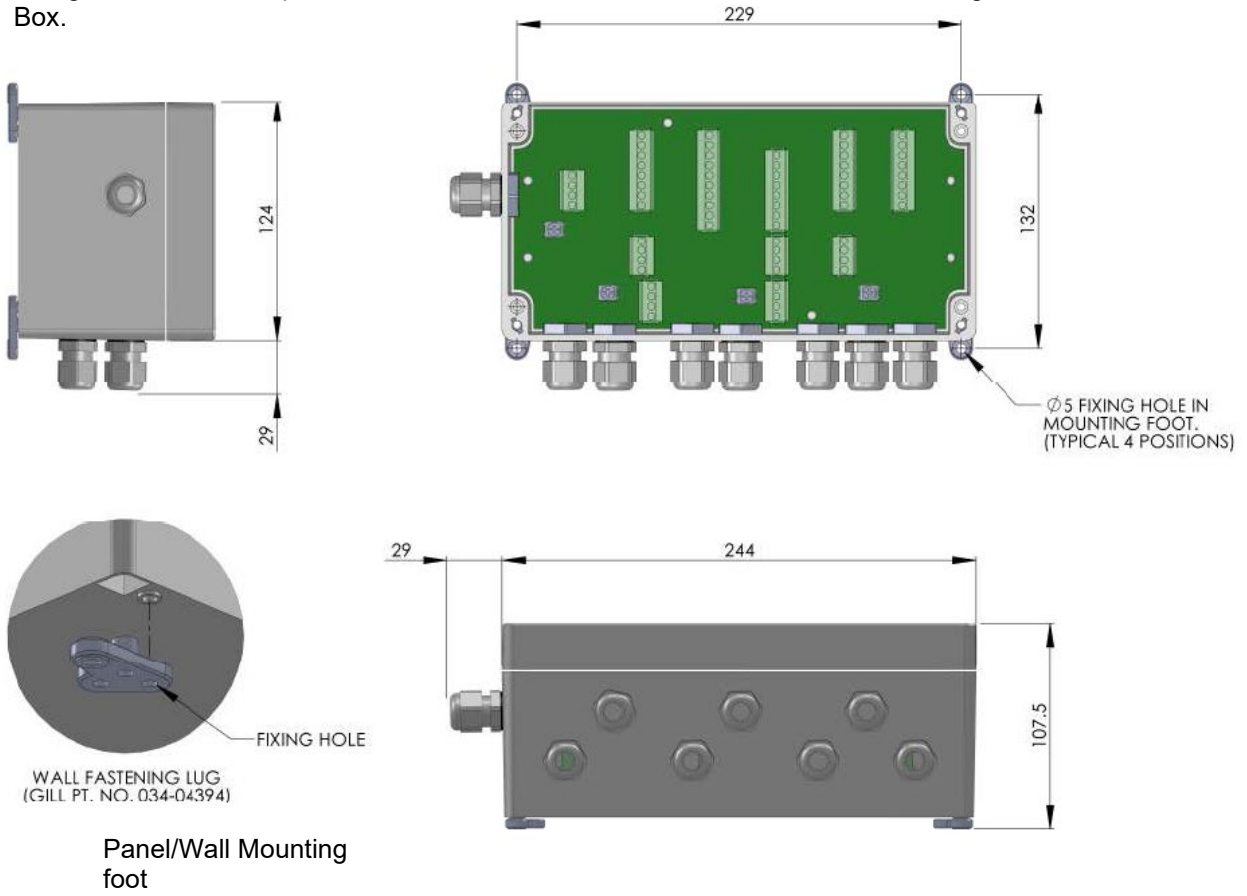

5.6. Mounting MetPak Base Station Heater Power Interface Box (Optional Item part 1723-PK-099)

This Interface box is an optional extra for orders for:-

MetPak Base Station 1723-1A-3-211 (with Heated WindSonic M).

MetPak Base Station 1723-1A-4-311 (with Enhanced Heated WindObserver).

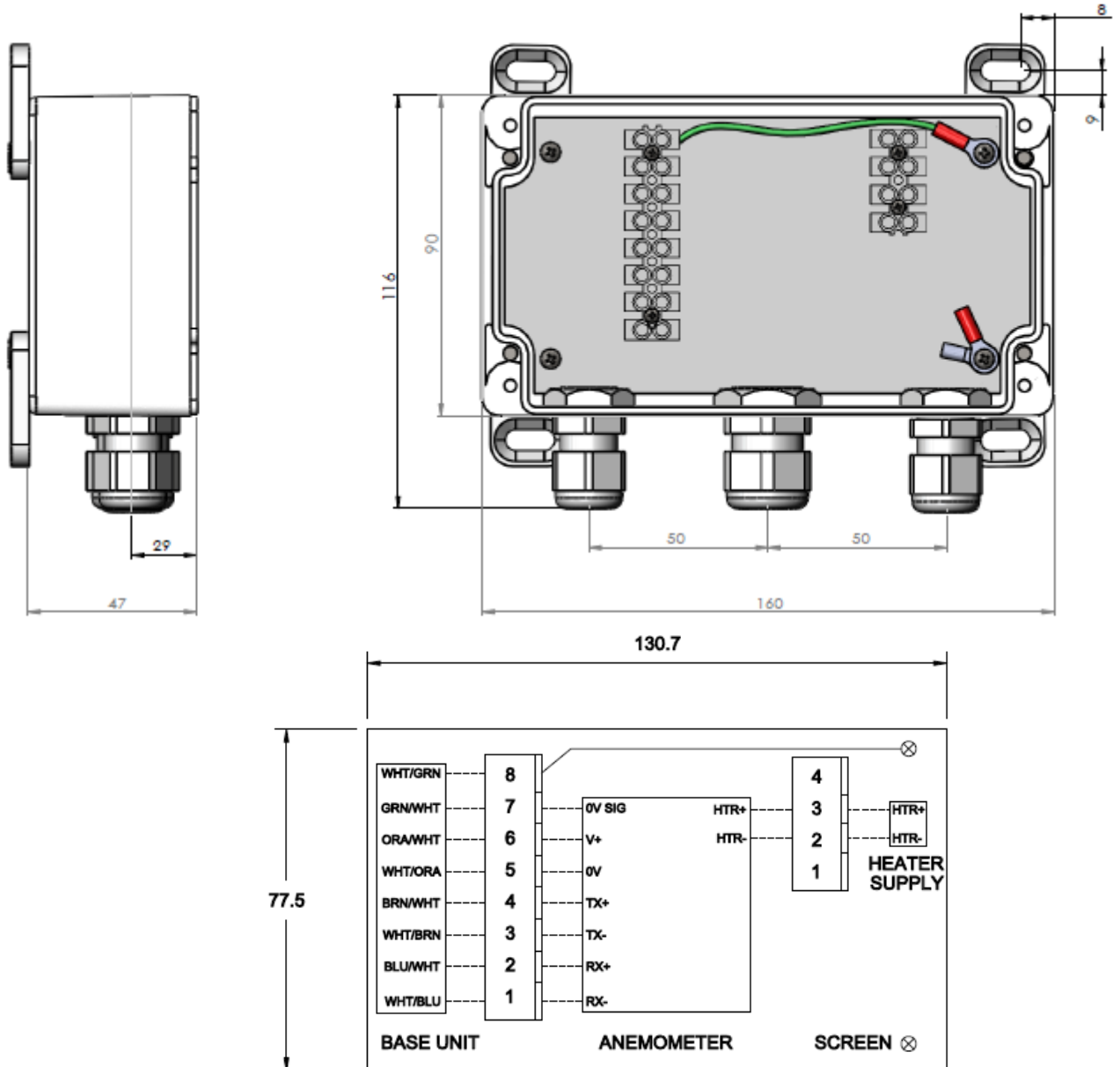

5.7. Solar Installation

If a Solar Sensor is used with a MetPak Pro Base Station it should be mounted horizontally and as level as possible.

A clear view of the sky is best for an optimal solar measurements. Mounting obstructions, tree canopy, hills, mountains and tall buildings that obscure the view overhead or of the horizon can impede solar readings.

If a solar sensor is incorporated with the Base Station then mount the unit as vertical as possible during installation for optimal readings.

6. CONFIGURING WITH METSET

MetPak Range Base Stations can be configured using Gill Instruments MetSet Software which can run on PC's running up to and including Windows 10 and can be downloaded from the Gill Website: <http://www.gillinstruments.com/main/software.html>.

6.1. MetPak Base Station Default Configurations

MetPak Base Station Factory Default Data String with 2 or 3 Axis Anemometer

NODE DIR SPEED **W-AXIS** PRESS RH TEMP DEWPOINT VOLT STATUS.

Q,170,000.08,+000.02,1019.5,035.0,+024.7,+008.3,+04.9,00, **55**

Where

<input type="checkbox"/>	STX
Q	Node Letter
170	Wind Direction
000.08	Wind Speed
+000.02	W Axis Wind Speed
1019.5	Pressure
035.0	Relative Humidity
+024.7	Temperature
+008.3	Dewpoint
+04.9	Supply Voltage
00	Status
<input type="checkbox"/>	ETX
55	Checksum

NOTES:

Items highlighted in Red apply to 3 Axis Base Stations only.

<STX> is the Start of String character (ASCII value 2).

<ETX> is the End of String character (ASCII value 3).

Checksum, the 2 digit Hex Checksum sum figure is calculated from the Exclusive OR of the bytes between (and not including) the STX and ETX characters

MetSet Reading MetPak Base Station Default Settings

Setting	Function	Setting	Function
Comms Levels	RS232	Sensor WindSpeed	On
Baud Rate	19200	Wind Speed Units	MS (Metres/Second)
Data Connection	Data Bits 8, Parity None, Stop Bits 1, Flow Control None.	Temperature Sensor	On
Node ID	Q	Temperature Units	C (Degrees Celsius)
Output rate	1Hz	Dewpoint Sensor	On
Message Mode	Continuous	Dewpoint Units	C (Degrees Celsius)
ASCII Set Up	Carriage return and line feed, Echo on	Pressure Sensor	On
North Alignment	0	Pressure Units	Hecto Pascals
		Humidity Sensor	On
Status Message Output	On	Humidity Units	%
Report Message Output	On	Report Format	Node, Polar (Wind Direction/Wind Speed), W Axis (wind speed) Pressure, Humidity, Temperature, Dewpoint, Volts, Status, Checksum.
Units Message Output	On		
Inputs Message Output	On		
Output Sentence	Comma Separated Variable		

MetPak Pro Base Station Factory Default Data String with 2 and 3 Axis Anemometer:

NODE,DIR,SPEED,W **AXIS**, PRESS, RH, TEMP, DEWPOINT,PRT,AN1,AN2,DIG1,VOLT, STATUS

□Q,014,000.06,**+000.02**,1011.2,042.1,+023.0,+009.4,,#,#,#,+04.9,00,□40

Where:-

□	STX
Q	Node letter
014	Wind direction
000.06	Wind speed
+000.02	W Axis Wind Speed
1011.2	Pressure
042.1	Humidity
+23.0	Temperature
+009.4	Dewpoint
,,	PRT (PRT not configured).
#	Analogue Input 1 (not configured)
#	Analogue Input 2 (not configured)
#	Digital Input 1(not configured)
+04.9	Supply voltage
00	Status code
□	ETX
40	Checksum

NOTES:

Items highlighted in Red apply to 3 Axis Base Stations only.

<STX> is the Start of String character (ASCII value 2).

,, is the default output for PRT until configured by MetSet.

is the default output for Analogue Inputs 1 & 2 and Digital Input 1 until configured by MetSet.

<ETX> is the End of String character (ASCII value 3).

Checksum, the 2 digit Hex Checksum sum figure is calculated from the Exclusive OR of the bytes between (and not including) the STX and ETX characters.

Example configured string is:-

Q,249,000.01,**+000.02**,1017.3,049.2,+021.4,+010.3,+040.45,+000.06,+000.04,0000.000,+11.6,00,7C

MetSet reading MetPak Pro Base Station Default Settings

Setting	Function
Comms Levels	RS232
Baud Rate	19200
Data Connection	Data Bits 8, Parity None, Stop Bits 1, Flow Control None.
Node ID	Q
Output rate	1Hz
Message Mode	Continuous
ASCII Set Up	Carriage return and line feed, Echo on
North Alignment	0
Sensor WindSpeed	On
Wind Speed Units	MS (Metres/Second)
Temperature Sensor	On
Temperature Units	C (Degrees Celsius)
Dewpoint Sensor	On
Dewpoint Units	C (Degrees Celsius)
Pressure Sensor	On
Pressure Units	Hecto Pascals
Humidity Sensor	On
Humidity Units	%
Report Format	Node, Polar (Wind Direction and Wind Speed), W Axis , Pressure, Humidity, Temperature, Dewpoint, PRT, AN1, AN2, DIG1, Volts, Status, Checksum.
Status Message Output	On
Report Message Output	On
Units Message Output	On
Inputs Message Output	On
PRT Sensor	On
PRT Units	C (Degrees Celsius)
AN1 Sensor Type	Not Configured
AN1 Units	#
AN1 Analogue Input Type	Not Configured
AN1 Substitute Name	-
AN2 Sensor Type	Not Configured
AN2 Units	#
AN2 Analogue Input Type	Not Configured
AN2 Substitute Name	-
DIG1 Sensor Type	Not Configured
DIG1 Units	#
DIG1 Digital Count	Not Configured
DIG1 Substitute Name	-
Output Sentence	Comma Separated Variable

6.2. Configuring MetPak Range Base Stations with MetSet

Before you use MetSet check that MetPak Base Station is correctly connected to a Serial COM port or USB COM port on your PC.

The optional Gill 1.8M, RS232 to USB cable (1723-PK-051) can be used to power and provide a suitable communication link for configuring a Base Station unit. If using the Gill Configuration RS232 to USB cable and a WindObserver or WindMaster is connected to a Base Station then the USB 5v power will not be sufficient to power them, the cable is provided only for hub box configuration.

NOTES:

MetSet is compatible with RS232 and RS422 connected units only.

The availability of certain functions and parameters illustrated will depend on the Base Station model and Options see Page 6, Para 2.1.2.

Opening MetSet

Click on the MetSet button on your PC's desktop or choose:

Start > All Programs > MetSet > MetSet

The MetSet Control Centre window is displayed. If you have more than one Base Station connected to your PC, MetSet, by default, selects the first device detected.

For most applications it is recommended to click on the MetSet **Connect and Read** button.

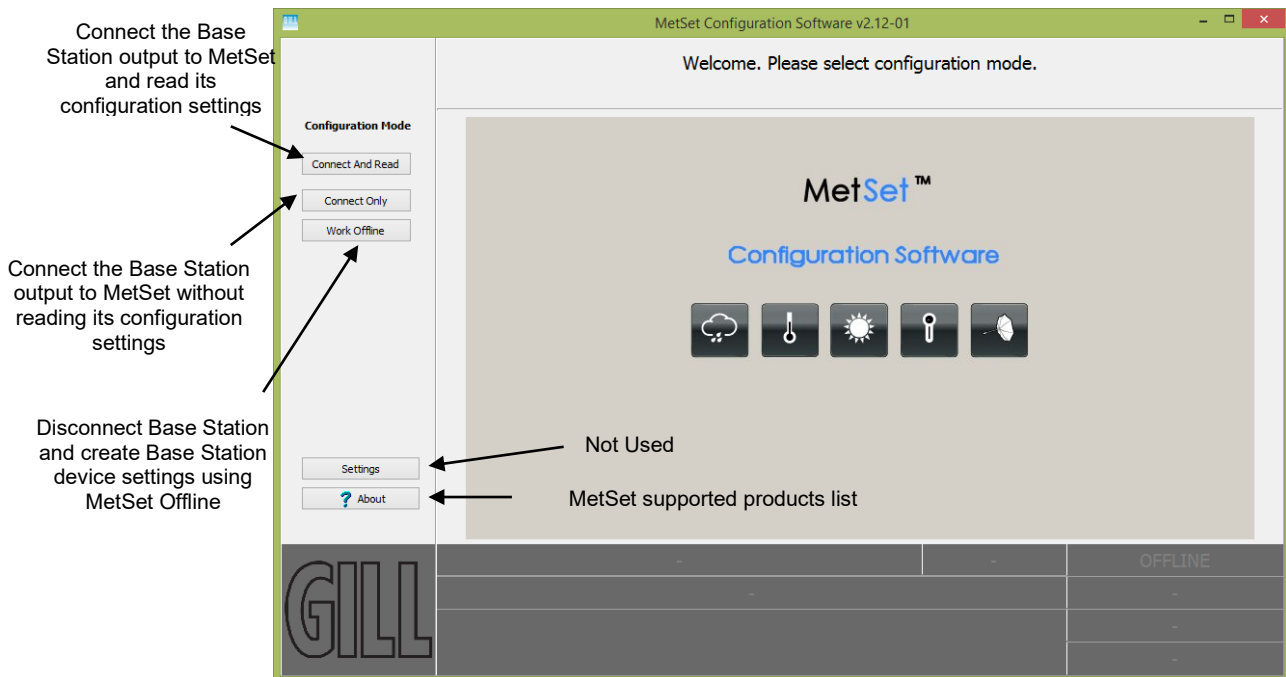

MetSet interrogates the Base Station and returns a summary of the device settings.

Depending on the Base Station Sensors connected only settings and parameters appropriate to the connected Base Station unit will be shown.

Note that MetSet also saves a copy of this screen to the connected PC as a Session Report File that can be accessed from the following destination.

C:\GillAppsData\Metset\SessionReports.

Example Summary of Device Settings (2 Axis MetPak Pro Base Station shown):-

SETTINGS ARE AS FOLLOWS:

PROTOCOL : GILL
COMMS : RS232
(BAUD) : 19200
NODE : Q
OUTFREQ : 1HZ
MSGMODE : CONT
ASCTERM : CRLF
ECHO : ON
ALIGN : 0
SENSOR WIND : ON
UNITS WIND : MS
NODIR : 0.00
SENSOR TEMP : ON
UNITS TEMP : C
SENSOR DEWPOINT : ON
UNITS DEWPOINT : C
SENSOR PRESS : ON
UNITS PRESS : HPA
SENSOR RH : ON
UNITS RH : %
REPORT NODE DIR SPEED PRESS RH TEMP DEWPOINT PRT AN1 AN2 DIG1 VOLT STATUS
PUPMSG STATUS : ON
PUPMSG REPORT : ON
PUPMSG UNITS : ON
PUPMSG INPUTS : ON
SENSOR PRT : ON
UNITS PRT : C
SENSOR AN1 : ON
SENSTYPE AN1 : NOT CONFIGURED
UNITS AN1 : #
ANIP AN1 : VOLTAGE 99999 99998
SUBST AN1 : NOT CONFIGURED
SENSOR AN2 : ON
SENSTYPE AN2 : NOT CONFIGURED
UNITS AN2 : #
ANIP AN2 : VOLTAGE 99999 99998
SUBST AN2 : NOT CONFIGURED
SENSOR DIG1 : ON
SENSTYPE DIG1 : NOT CONFIGURED
UNITS DIG1 : #
DIGCOUNT DIG1 : 10.000
SUBST DIG1 : NOT CONFIGURED
MODBUS : RTU
MODADDR : 1
DATABITS : 8
STOPBITS : 1
PARITY : NONE
MODTERM : 10
MODICT : 1000

Note changes to BAUD and COMMS settings will take place after next power-up.

Click on the Close button to continue to the MetSet set up screen.

MetSet Editing Screen

When connected correctly a MetSet editing screen is available to read configuration settings, change configuration settings, save Base Station configuration settings to a PC file location, upload Base Station configuration settings from a PC file and view the Base Station raw data string output.

MetSet Editing Screen

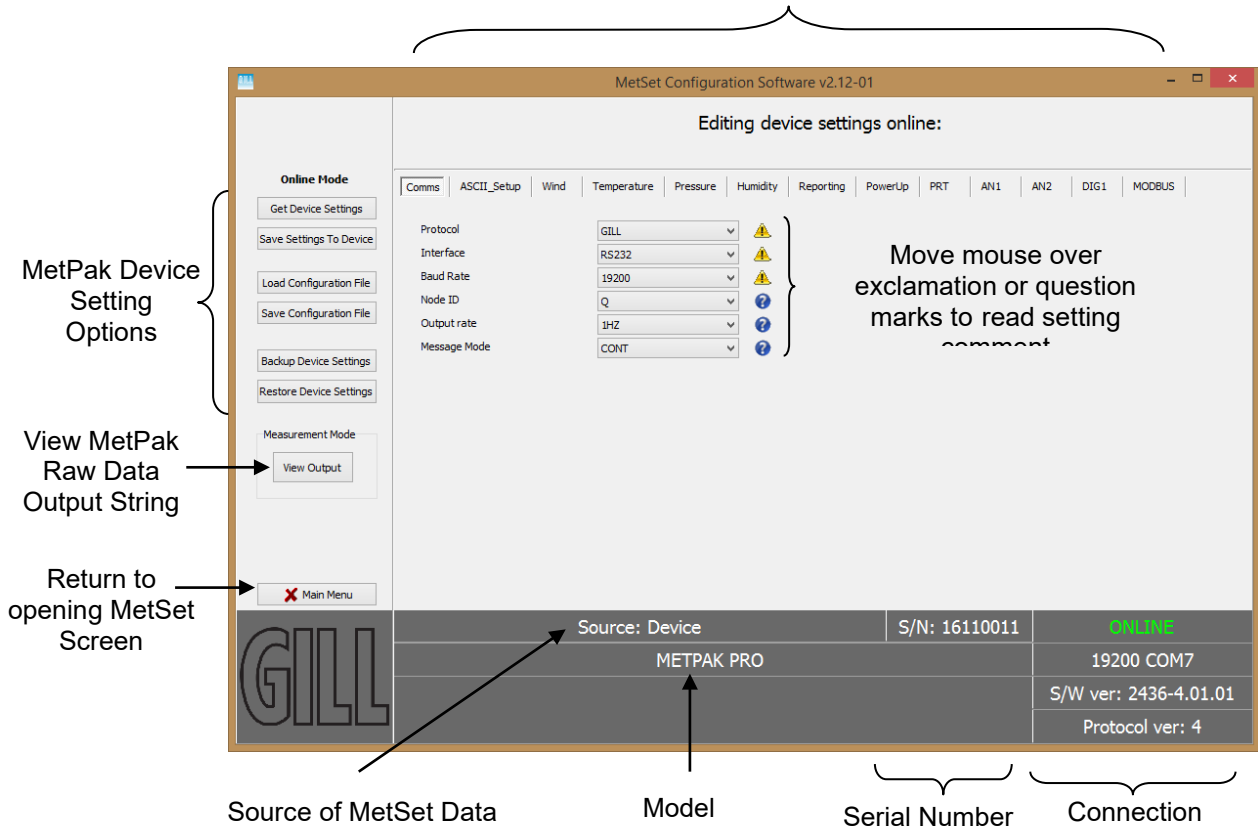

MetSet Connection Status Information.

Reading	Function
ONLINE	ONLINE in green indicates the Base Station has been successfully connected to MetSet. OFFLINE in Grey indicates that MetSet is being used without a Base Station in communication with MetSet.
19200 COM7	19200 is a report on the Base Station Baud rate setting. COM 7 is a report on the Base Station COM Port connection number.
S/W ver 2436-4.01.01	2436 is the Base Station Firmware number. 4.01.01 is the firmware revision. PV=4 is the Protocol Version (Gill Internal Reference).
Source:Device	MetSet reads 'Device' when the source of the data that MetSet has retrieved has come from the Base Station Model. MetSet reads 'File' when the source of data has come from a saved file. MetSet reports on the connected Base Station device (METPAK PRO) and reads the unit Serial Number (S/N: 16110011)

If the Source Device is a 3 Axis Base Station then this will be identified by including UVW alongside its title.

Source: Device	S/N: 14290004
METPAK II UVW	

• **MetSet Online Settings.**

Online Mode

Get Device Settings

Save Settings To Device

Load Configuration File

Save Configuration File

Backup Device Settings

Restore Device Settings

Online Mode Buttons	Function
Get Device Settings	MetSet retrieves the Base Station Configuration settings.
Save Settings to Device	MetSet configuration settings are saved to a connected Base Station.
Load Configuration File	When selected MetSet retrieves a MetSet edit PC file and updates MetSet with these settings.
Save Configuration File	When selected MetSet edit settings are saved to a PC file location.
Back Up Device Settings	When selected the Base Station configuration settings are transferred to MetSet and then to a file location selected on a PC.
Restore Device Settings	When selected MetSet retrieves a Base Station configuration setting from a PC file, loads it into the Base Station and updates the MetSet edit settings.
Measurement Mode View Output	Click on View Output to view the raw ASCII Base Station data string scrolling at the output rate. (View only feature). E.g. Q,127,000.03,000,2000-01-01T00:40:50.2,+10.5,0000, 21
Main Menu	Click here to go back to the opening MetSet screen

MetSet Editing Pages.

Features and Parameters available to view and select will depend on the Base Station model connected. See page 6 for a summary of available sensor outputs and parameters.

NOTE: Items shown in Bold are the default settings.

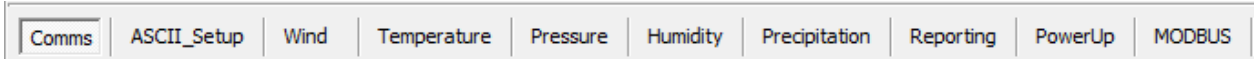

The Comms Page can be used to Select:-

Protocol	GILL	
Interface	RS232	
Baud Rate	19200	
Node ID	Q	
Output rate	1HZ	
Message Mode	CONT	

- Protocol:- **GILL**, or MODBUS
- Interface:- **RS232**, RS422, RS485P2W (point to point), SDI-12.
- Baud Rate:- 4800, 9600, **19200**, 38400 or 57600
(1200 baud auto selected with SDI-12 setting).
- Node ID:- A to P, **Q** to Z.
- Output Rate:- **1Hz (1 per second)**, 1/2Hz and 1/4Hz.
- Message Mode:- **CONT** (Continuous output) or POLL (Polled Mode).

NOTES:

When COMMS or Baud Rate settings are changed and Saved to Device a warning is issued by MetSet. These setting changes will not become active until the Base Station power is turned off and turned on again. The connecting device will then also need its Comms and Baud rate settings changed to match the Base Station.

When selecting Modbus then Message Mode must be set for CONT.

The ASCII Set up Page can be used to select:-

- Termination:- **CRLF** or CR
- Echo:- **ON** or OFF.

The **Wind Page** can be used to select:-

North Alignment from **0-359** degrees. If the unit is installed on the mast and found to be off North alignment then an offset figure can be set to correct for this.

Sensor WindSpeed **ON** or OFF.

Wind Speed Units **MS**, KTS, MPH, KPH, FPM.

(Metres/Second, Knots (Nautical miles/hour), Miles/Hour, Kilometres/Hour, Feet/Minute).

No-Direction Wind Speed **0.00**m/s to 5.00m/s speed above which direction readings are output.

The **Temperature Page** can be used to select:-

Temperature Sensor **ON** or OFF

Temperature Units **C**, K or F (Centigrade, Kelvin, Fahrenheit)

Dew Point Sensor **ON** or OFF

Dew Point Units **C**, K or F

The **Pressure Page** can be used to select:-

Pressure Sensor **ON** or OFF

Pressure Units **HPA**, MB, MMHG, INHG (Hecto Pascals, Milli-Bars, Millimetres Mercury, Inches Mercury).

The **Humidity Page** can be used to select:-

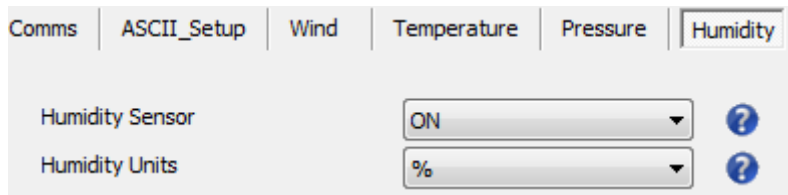

Humidity Sensor **ON** or OFF

Humidity Units **%**

The **Reporting Page** can be used to select:-

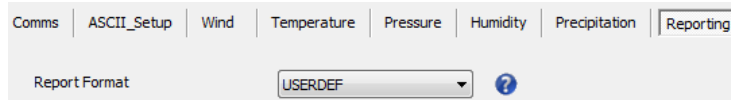

Report Format **USERDEF**, FULL or NMEA (NMEA MetPak unit only not RG or Pro versions)

FULL Factory setting, outputs each available sensor field.

USERDEF Report parameters can be selected in any order or on or off in USERDEF setting.

NMEA Sets the unit to output an NMEA data string (MetPak Base Station unit only not MetPak RG/MetPak Pro Base Station units).

Select Parameters to Report.

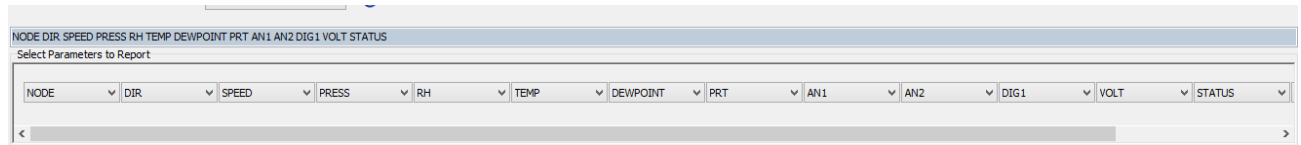

Actual reported parameters and order of output shown will depend on the Base Station Model and for more details on derived parameters refer to page 6.

- Blank Field ,,,
- NODE Outputs a Node letter (A to Z).
- DIR Outputs Wind Direction readings.
- SPEED Outputs Wind Speed readings.
- PRESS Outputs the Barometric Pressure reading.
- RH Outputs Relative Humidity reading.
- TEMP Outputs the Temperature reading.
- DEWPOINT Outputs the Dewpoint reading.
- VOLT Outputs the Base Station Supply Voltage.
- PRT MetPak Pro Base Station only, with a connected Platinum Resistance Thermometer, outputs a temperature reading.
- STATUS. Outputs the Base Station Sensors Status Code (see para 8.3.2).
- AN1 MetPak Pro Base Station only. Outputs data from a connected analogue instrument.
- AN2 MetPak Pro Base Station only. Outputs data from a connected analogue instrument.
- DIG1 MetPak RG and MetPak Pro Base Stations only, with a connected Tipping Bucket Rain Gauge it outputs precipitation in the output period.

The **PowerUp Page** can be used to select:-

Status Message Output **ON** or OFF.

E.g. METPAK PRO 2436 V4.01.01
STARTUP: OK.

Report Message Output **ON** or OFF.

E.g. NODE,DIR,SPEED,PRESS,RH,TEMP,DEWPOINT,PRT,AN1,AN2,DIG1,VOLT,STATUS,CHECK.

Units Message Output **ON** or OFF

E.g. - DEG,MS,HPA,%,C,C,C,#,#,V,-,-

Inputs Message Output **ON** of OFF.

E.g. PRT = CONFIGURED
AN1 = NOT CONFIGURED
AN2 = NOT CONFIGURED
DIG1 = NOT CONFIGURED

The **PRT Page** (MetPak Pro Base Station) can be used to select:-

PRT Sensor **ON** or OFF

PRT Units **C**, K or F

(Celsius, Kelvin or Fahrenheit)

The output data format for PRT data is Sign (+ or -), 3 integral digits, and 2 decimal places.

The **AN1** and **AN2** Pages (MetPak Pro Base Station) can be used to select:-

AN1 or 2 Sensor **ON** or OFF

Sensor Type – Choose a title from drop down list.

Units – Allows a choice of measurement units depending on sensor chosen.

Analogue Input Type – Select Voltage or Current.

Substitute Name field available for typing in a substitute name between 3 to 8 characters long.

Low – Match to low scale of external sensor (± 9998.0000 possible).

High – Match to high scale of external sensor (± 9998.0000 possible).

MetSet AN1 and AN2 Edit pages can be used to set a MetPak Pro Base Station low value and high value range figure to be input to match the output range of the connected sensor.

For instance if a 0-5v Pressure Sensor scaled over a range of 600 to 1100 Milli-bars is connected to AN1, then set MetSet AN1 Edit Screen for low value 600 and high value to 1100 and save this as device setting.

The MetPak Pro Base Station will then output the actual pressure reading value e.g. 1027.1 in the AN1 position of the digital data string.

Similarly if a 0-5v Temperature probe were used on AN2 scaled over a range -50 to $+70$ degrees, then set AN2 low value to -50 and high value to 70.

NOTE:

In the event that the input voltage exceeds 5.05v dc an overflow character E will appear in the digital data string.

In the event that the input current is less than 3.96mA an error character X will appear in the digital data string.

In the event that the input current is more than 20.2mA an overflow character E will appear in the digital data string.

The **DIG1 Page** (MetPak Pro Base Station) can be used to select:-

DIG1 Sensor **ON** or OFF

Sensor Type - Choose a title from a drop down list.

Units - Allows a choice of measurement units depending on sensor chosen. For instance MM or IN for Rain.

Count can be set from 0.001 to **10.000** in 0.001 unit steps to represent one switch closure taking place.

If using a Rain Gauge it should be set to match the Rain Gauge calibration figure for example 0.199 (mm/hr.).

Substitute Name - A field available for typing in a user name between 3 to 8 characters long.

In Continuous Output Mode

A count will occur of the number of switch closure events taking place over 1 second (default 1Hz output rate or during 2 seconds (0.5Hz) or during 4 seconds (0.25Hz)) and will be output in each digital data output reading (when DIG 1 enabled).

In Polled Mode

The MetPak Pro Base Station will store and output the cumulative total number of switch closures since the last poll request. Once the cumulative total has been output the count will be reset to zero.

The maximum number of count events will be 9999, if the number counted exceeds 9999 an overflow character E will be output in the data string.

NOTE:

Once all settings have been chosen then save Edited Page Settings to MetPak RG/Pro Base Station by clicking on 'Save Settings to Device' this will change the MetPak RG/Pro Base Station configuration to reflect the new MetSet settings.

The **MODBUS Page** can be used to select:-

Comms	ASCII_Setup	Wind	Temperature	Pressure	Humidity	Precipitation	Reporting	System	PowerUp	MODBUS
Mode	RTU									
Address	1									
Data bits	8									
Stop bits	1									
Parity	NONE									
Termination Char ASCII code	10									
Inter-char timeout (ms)	1000									

Mode	RTU or ASCII.
Address	1 to 247.
Data Bits	8 for Modbus RTU , 7 for Modbus ASCII.
Stop Bits	2 for No Parity , 1 for Even/Odd Parity.
Parity	NONE , ODD, or EVEN.
Termination Char ASCII code	10 , (0-255).
Inter Char Timeout (mS)	1000 (500 to 10000).

6.3. Configuring a Base Station for Polled Mode

6.3.1 To Configure a Base Station Unit for Polled Mode:

Connect a default set Base Station to a PC as described in Para 4.9.

Open MetSet as described on Para 6.2.

Click on the Edit Comms page and select:-

Set Protocol for required poll mode interface e.g. RS485P2W and

Set Message Mode to Poll.

Click on Save Settings to Device on the Online Mode Menu.

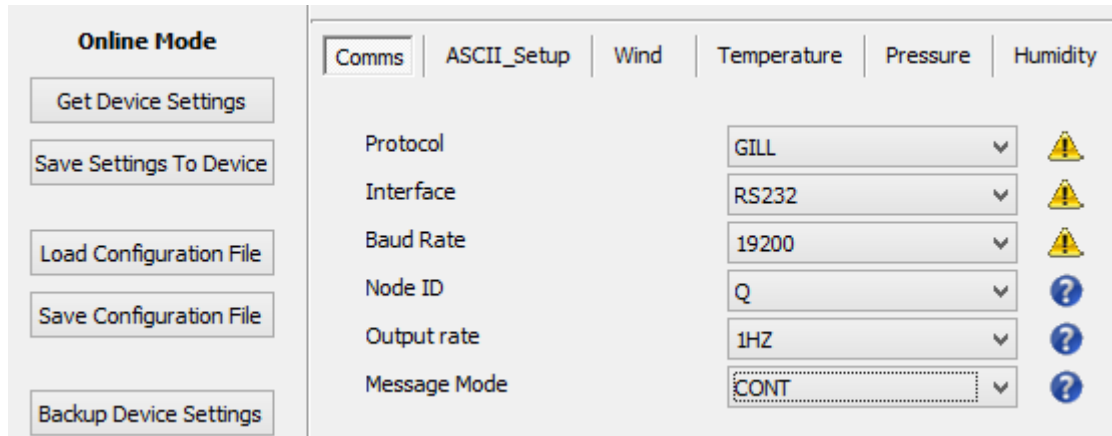

Shut down the Base Station unit.

Change the hardware connections for the required Poll Mode Interface.

E.g. RS485P2W in para 4.11.

6.3.2 Using Polled Mode:

When in the Polled mode, an output is only generated when the host system sends a Poll signal to the Base Station consisting of a ? Character followed by the Base Station Node ID – that is, the relevant letter A – Z.

The commands available in Polled mode are:

Description	Command	Base Station Response
Enable Polled mode	?	(None)
Base Station ID	A Z	Data output generated
Disable Polled mode	!	(None)
Request Base Station Unit Identifier	?&	A Z (as configured)

It is suggested that in polled mode the following sequence is used for every poll for information.

? Ensures that the Sensor is enabled to cover the event that a power down has occurred.

A-Z Appropriate unit designator sent to retrieve a line of data (default is Q).

! Sent to disable poll mode and reduce possibility of erroneous poll generation.

When in polled mode the system will typically respond to the data command within 30mS with the last valid data sample when set for 1Hz output rate.

If a Wind Sensor is not connected to the base station then allow at least 3 seconds for a poll request reading output.

If the unit is powered down after use or upon switch on then allow 10 seconds from switch on before sending poll commands.

6.4. Configuring a Base Station for SDI-12

To configure a Base Station unit for SDI-12:

Connect a default set Base Station to a PC as described in Para 4.9.

Open MetSet as described on Para 6.2.

Click on the Edit Comms page and select:-

Set Interface for SDI-12.

No other settings changes are required.

Click on Save Settings to Device on the Online Mode Menu.

The screenshot shows the MetSet software interface. On the left, the 'Online Mode' menu is visible with buttons for 'Get Device Settings', 'Save Settings To Device', 'Load Configuration File', 'Save Configuration File', and 'Backup Device Settings'. The main window displays the 'Comms' configuration page, which includes tabs for 'Comms', 'ASCII_Setup', 'Wind', 'Temperature', 'Pressure', and 'Humidity'. The 'Comms' tab is active, showing the following settings:

Protocol	GILL	⚠
Interface	RS232	⚠
Baud Rate	19200	⚠
Node ID	Q	?
Output rate	1HZ	?
Message Mode	CONT	?

Shut down the Base Station unit.

Change the hardware connections for SDI-12 (see Para 4.12).

Power up the Base Station unit (**SDI-12 supply voltage 9.6v to 16v dc**).

6.4.1. SDI-12 Units of Measure

NOTE

Not all the following outputs are available and will depend on the Base Station variant, see page 6, Para 2.1.2.

Base Station SDI-12 Output Parameters.

Relative Wind Speed:	Metres/Second.
Relative Wind Direction:	Degrees
Temperature:	Degrees C
Relative Humidity:	%
Dewpoint:	Degrees C
Pressure:	Hecto Pascals
Total precipitation:	mm
AN1	As defined by MetSet
AN2	As defined by MetSet
DIG1	As defined by MetSet
PRT	As defined by MetSet
Date:	yyyymmdd
Time:	hhmmss
Status	4 Digit Sensor Status code (e.g. 00 for a no fault condition)

6.4.2. SDI-12 Commands

Note: Unavailable measurements shall be "padded", e.g.: +999.99.

?!	Unit Address (default is 0).
aAb!	Change unit address (a = 0).
al!	Unit identifier Firmware and Serial Number.
aM!	Wind Direction/Speed (direction in Degrees, speed in Metres/Sec), Temperature (degrees C), Pressure (Hecto Pascals/millibars) and Humidity (%).
aM1!	Wind Direction/Speed (direction in Degrees, speed in Metres/Sec), Temperature (degrees C), Pressure (Hecto Pascals/millibars) and Dewpoint (degrees C).
aM2!	Wind Direction/Speed (direction in Degrees, speed in Metres/Sec) and a 2 digit Wind only Status Codes.
aM3!	Temperature (degrees C), Humidity (%), Dewpoint (Degrees C) and full Base Station Status Codes.
aM4!	Pressure (Hecto Pascals/millibars).
aM5!	PRT, Analogue Input 1, Analogue input 2 and Digital Input 1.
aM6!	PRT.
aM7!	Analogue Input 1 and Analogue Input 2.
aM8!	Digital Input 1.
aM9!	Power Supply Voltage (Volts).
aD0!	Request a line of the above data.

Command	Description	Response	Example
?!	Unit Address	a<CR><LF>	0<CR><LF>
aAb!	Change the unit address a = 0, the default. b = the new address.	b<CR><LF>	1<CR><LF>
al!	Send Unit Identification	a><firmware><sn><CR><LF>	013GillInst 40116370005<CR><LF>
aM!	Wind Direction/Speed (direction in Degrees, speed in Metres/Sec), Temperature (degrees-C), Pressure (Hecto Pascals/millibars), Humidity (%) and a 2 digit Status Code	atttn<CR><LF> a is unit identifier. t is time in seconds. n is number of data values. Measurement command to retrieve a reading of the maximum time the Base Station will take to complete a measurement, have data ready and the number of data values.	00055<CR><LF> 0 is unit identifier. 005 is 5 sec. measurement. 5 is the number of data readings (Direction, Speed, Temperature, Pressure and Humidity).
0D0!	Retrieve a line of the above data.	a<dir><mag><temp><pressure><humidity><CR><LF>	0+220+000.01+021.6+1013.0+041.9<CR><LF>

aM1!	Wind Direction/Speed (direction in Degrees, speed in Metres/Sec), Temperature (degrees C), Pressure (Hecto Pascals/millibars) and Dewpoint (degrees C).	atttn<CR><LF>	00055<CR><LF>
0D0!	Retrieve a line of the above data.	a<dir><mag><temp><pressure><dewpoint><CR><LF>	0+357+000.03+021.6+1013.0+008.0<CR><LF>
aM2!	Wind Direction/Speed (direction in Degrees, speed in Metres/Sec) and a 2 digit Wind only Status Code.	atttn<CR><LF>	00053<CR><LF>
0D0!	Retrieve a line of the above data.	a<dir><mag><status><CR><LF>	0+029+000.01+00<CR><LF>
aM3!	Temperature (degrees C), Humidity (%), Dewpoint (Degrees C) and Full Sensor Status Codes.	atttn<CR><LF>	00054<CR><LF>
0D0!	Retrieve a line of the above data.	a<temp><humidity><dewpoint><status><CR><LF>	0+21.6+041.0+0007.8+00<CR><LF>
aM4!	Pressure (Hecto Pascals/millibars).	atttn<CR><LF>	00051<CR><LF>
0D0!	Retrieve a line of the above data.	a<pressure><CR><LF>	0+1013.0<CR><LF>
aM5!	PRT, Analogue Input 1, Analogue Input 2 and Digital Input 1	atttn<><CR><LF>	00054<CR><LF>
0D0!	Retrieve a line of the above data.	a<prt><AI1><AI2><dig1><CR><LF>	0+027.65+0.0034-099903+0135.000<CR><LF>
AM6!	PRT.	atttn<CR><LF>	00051<CR><LF>
0D0!	Retrieve a line of the above data.	a<prt><CR><LF>	0+027.65<CR><LF>
AM7!	Analogue Input 1 and Analogue Input 2	atttn<><CR><LF>	00052<CR><LF>
0D0!	Retrieve a line of the above data.	a<AI1><AI2><CR><LF>	0+3.5380+017947<CR><LF>
AM8!	Digital Input 1.	atttn<CR><LF>	00051<CR><LF>
0D0!	Retrieve a line of the above data.	a<dig1><CR><LF>	0+0408.000<CR><LF>
aM9!	Power Voltage (Volts)	atttn<CR><LF>	00011<CR><LF>
0D0!	Retrieve a line of the above data.	a<voltage><CR><LF>	0+12.5<CR><LF>

6.4.3. SDI-12 Commands with CRC

Note: Unavailable measurements shall be "padded", e.g.: +999.99.

aMC!	Wind Direction/Speed (direction in Degrees, speed in Metres/Sec), Temperature (degrees C), Pressure (Hecto Pascals/millibars), Humidity (%) and CRC.
aMC1!	Wind Direction/Speed (direction in Degrees, speed in Metres/Sec), Temperature (degrees C), Pressure (Hecto Pascals/millibars), Dewpoint (degrees C) and CRC.
aMC2!	Wind Direction/Speed (direction in Degrees, speed in Metres/Sec), a 2 digit Status Code and CRC.
aMC3!	Temperature (degrees C), Humidity (%), Dewpoint (degrees C) and CRC.
aMC4!	Pressure (Hecto Pascals/millibars) and CRC.
aMC5!	PRT, Analogue Input 1, Analogue input 2, Digital Input 1 and CRC.
aMC6!	PRT and CRC.
aMC7!	Analogue Input 1, Analogue Input 2 and CRC.
aMC8!	Digital Input 1 and CRC.
aMC9!	Power Supply Voltage (Volts) and CRC.
aD0!	Request a line of the above data.

Command	Description	Response	Example
aMC!	Wind Direction/Speed (direction in Degrees, speed in Metres/Sec), Temperature (degrees C), Pressure (Hecto Pascals/millibars) Humidity (%) and CRC.	atttn<CR><LF> a is unit identifier. t is time in seconds. n is number of data values. Measurement command to retrieve a reading of the maximum time the Base Station will take to complete a measurement, have data ready and the number of data values.	00055<CR><LF> 0 is unit identifier. 005 is 5 sec. measurement. 6 is the number of data readings (Direction, Speed, Temperature, Pressure, Humidity and CRC).
0D0!	Retrieve a line of the above data.	a<dir><mag><temp><pressure><humidity><CRC><CR><LF>	0+139+000.06+022.2+1017.8+042.7BIQ<CR><LF>
aMC1!	Wind Direction/Speed (direction in Degrees, speed in Metres/Sec), Temperature (degrees C), Pressure (Hecto Pascals/millibars), Dewpoint (degrees C) and CRC.	atttn<CR><LF>	00055<CR><LF>
0D0!	Retrieve a line of the above data.	a<dir><mag><temp><pressure><dewpoint><CRC><CR><LF>	0+140+000.06+022.2+1017.7+009.0D{Z<CR><LF>
aMC2!	Wind Direction/Speed (direction in Degrees, speed in Metres/Sec), a 2 digit Status Code and CRC.	atttn<CR><LF>	00053<CR><LF>
0D0!	Retrieve a line of the above data.	a<dir><mag><status><CRC><CR><LF>	0+098+000.04+00@sh<CR><LF>

aMC3!	Temperature (degrees C), Humidity (%), Dewpoint (Degrees C) and CRC.	atttn<CR><LF>	00053<CR><LF>
0D0!	Retrieve a line of the above data.	a<temp><humidity><dewpoint><status><CRC><CR><LF>	0+022.2+042.7+009.0+00LV{<CR><LF>
aMC4!	Pressure (Hecto Pascals/millibars) and CRC.	atttn<CR><LF>	00051<CR><LF>
0D0!	Retrieve a line of the above data.	a<pressure><CRC><CR><LF>	0+1017.8GM□<CR><LF>
aMC5!	PRT, Analogue Input 1, Analogue Input 2, Digital Input 1 and CRC.	atttn<><CR><LF>	00054<CR><LF>
0D0!	Retrieve a line of the above data.	a<prt><AI1><AI2><dig1><CRC><CR><LF>	0-001.19+0000.6+0000.4+0000.000 CQx <CR><LF>
aMC6!	PRT and CRC.	atttn<CR><LF>	00051<CR><LF>
0D0!	Retrieve a line of the above data.	a<prt><CRC><CR><LF>	0-001.19IT@<CR><LF>
aMC7!	Analogue Input 1, Analogue Input 2 and CRC.	atttn<><CR><LF>	00052<CR><LF>
0D0!	Retrieve a line of the above data.	a<AI1><AI2><CRC><CR><LF>	0+0000.6+0000.4FE~<CR><LF>
aMC8!	Digital Input 1 and CRC.	atttn<CR><LF>	00051<CR><LF>
0D0!	Retrieve a line of the above data.	a<dig1><CRC><CR><LF>	0+0000.000EgO<CR><LF>
aMC9!	Power Voltage (Volts) and CRC	atttn<CR><LF>	00011<CR><LF>
0D0!	Retrieve a line of the above data.	a<voltage><CRC><CR><LF>	0+12.2K@R<CR><LF>

6.5. Configuring a Base Station for MODBUS

NOTE:- Applies only to Parts 1723-XX-X-X31 or X32 with firmware 2436 4.02.04.

6.5.1 Base Station Supported Modbus Specification

MODBUS RTU or ASCII.
 Baud Rate 9600 or 19200 Baud.
 COMMS RS232 point to point only, RS485 2 wire networkable.
 Modbus Parameters ASCII or RTU.

Parameter	Modbus ASCII		Modbus RTU	
Character	ASCII 0 to 9 and A to F (Hex)		Binary 0 to 255	
Error Check	Longitudinal Redundancy Check (LRC)		Cyclic Redundancy Check (CRC)	
Frame Start	Character ':' (3A Hex)		3.5 Characters Silence	
Frame End	Characters CR/LF (0D/0A Hex)		3.5 Characters Silence	
Gaps in Message	1 Second		1.5 Times Character Length	
Start Bit	1		1	
Data Bits	7		8	
Parity	Even/Odd	None	Even/Odd	None
Stop Bits	1	2	1	2

Read Holding Registers function code is 0x03
 Diagnostics 0x08
 Get Comm event counter 0x0B
 Report slave/server ID 0x11

Requires:-

Base Station units with version 2346-4.02.04 firmware.

MetSet Software version 2.12-01 and onwards.

Connect a Base Station to a PC COM port (default communication is RS232).

Open Gill MetSet Software.

Click on Connect and Read to reach the Editing Pages as shown below.

Configuration

Click on the MODBUS Page.

- Mode: Choose between RTU and ASCII, in this case RTU.
- Address: Choose a Base Station Address number between 1 to 247.
- Data Bits: Choose 7 for Modbus ASCII and 8 for Modbus RTU.
- Stop Bits: Choose 1 for Even/Odd Parity or 2 for No Parity (None).
- Parity: Choose Even/Odd or None.
- Termination Char ASCII code: Choose between 0-255.
- Inter Char Timeout (ms): Choose between 500ms to 10000ms.

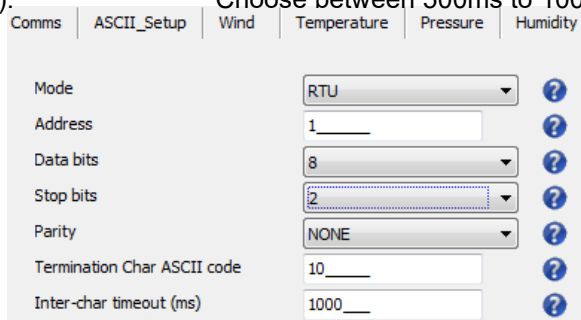

Select the COMMS Page

- Protocol: Default is Gill. Select MODBUS
- Interface: Default is RS232. Select RS232 or RS485P2W. RS232 will only allow a single point to point non multi drop network connection. RS485 2 wire will allow networking with up to 32 connected devices.
- Baud Rate: Default is 19200. Select required Baud rate (9600 or 19200 supported).
- Node ID: Default is Q. Not used for MODBUS.
- Output Rate: Default is 1Hz. Set update rate for Base Station Data.
- Message Mode: Default is CONT. Select POLL mode and the Base Station will only make and output a measurement (set by the output rate) on demand from the Modbus Master. In CONTinuous mode the Base Station continuously makes measurements set by output rate (0.25Hz to 1Hz) and only outputs a result when demanded from the Modbus Master.

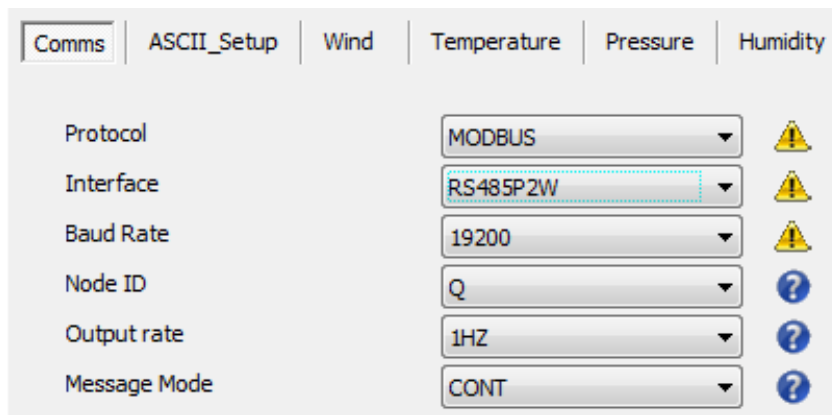

When required settings have been selected click on Save Settings to Device

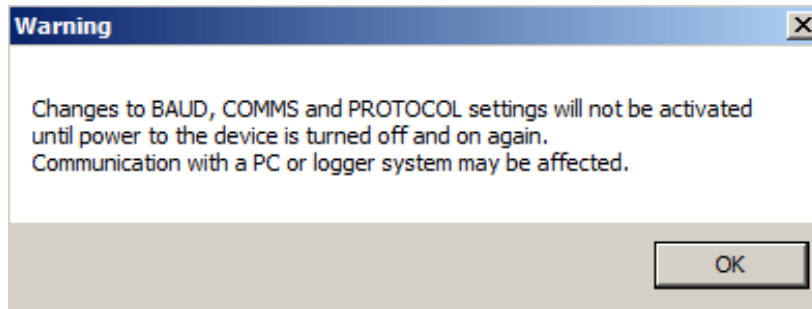

Click on Yes and OK.

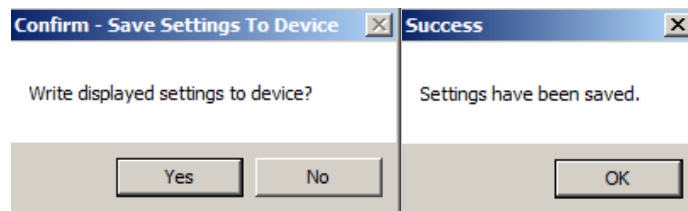

Power down the Base Station and apply power back to the Base Station to complete setting changes.

Note: now that the unit is in MODBUS mode if any further changes need to be made use the SAFE MODE connection and method to re-establish communication with MetSet (See Para 6.7).

Base Station MODBUS NOTES

To work out Modbus register numbers applicable to a Base Station parameter, start out with setting up the Base Station in ASCII mode and determining which parameters are to be output, and the exact order that they are to be output before setting to Modbus Comms.

Refer to the Modbus output parameter tables (shows 2 axis Base Stations) below to determine how many registers each chosen parameter will take up.

Fill up the register table, starting at 40001, with the required output parameters in the order in which they will be output.

Note: After powering up the Base Station, wait 10 seconds before requesting any measurements.

MetPak Base Station Output Parameters	Type	No. of Registers	Register Numbers
NODE	4 Bit Character String	2	40001-2
DIRECTION	32 Bit Floating Point Value	2	40003-4
SPEED	32 Bit Floating Point Value	2	40004-5
PRESSURE	32 Bit Floating Point Value	2	40006-7
RELATIVE HUMIDITY	32 Bit Floating Point Value	2	40008-9
TEMPERATURE	32 Bit Floating Point Value	2	40010-11
DEWPOINT	32 Bit Floating Point Value	2	40012-13
SUPPLY VOLTAGE	32 Bit Floating Point Value	2	40014-15
STATUS	32 Bit Unsigned Integer (UINT)	2	40016-17

MetPak Pro Base Station Output Parameters	Type	No. of Registers	Register Numbers
NODE	4 Bit Character String	2	40001-2
DIRECTION	32 Bit Floating Point Value	2	40003-4
SPEED	32 Bit Floating Point Value	2	40005-6
PRESSURE	32 Bit Floating Point Value	2	40007-8
RELATIVE HUMIDITY	32 Bit Floating Point Value	2	40009-10
TEMPERATURE	32 Bit Floating Point Value	2	40011-12
DEWPOINT	32 Bit Floating Point Value	2	40013-14
PRT	32 Bit Floating Point Value	2	40015-16
AN1	32 Bit Floating Point Value	2	40017-18
AN2	32 Bit Floating Point Value	2	40019-20
DIG1	32 Bit Floating Point Value	2	40021-22
SUPPLY VOLTAGE	32 Bit Floating Point Value	2	40023-24
STATUS	32 Bit Unsigned Integer (UINT)	2	40025-26

ModBus Parameter tables for Default set 3 Axis Base Stations.

MetPak Base Station Output Parameters	Type	No. of Registers	Register Numbers
NODE	4 Bit Character String	2	40001-2
DIRECTION	32 Bit Floating Point Value	2	40003-4
SPEED	32 Bit Floating Point Value	2	40004-5
W AXIS	32 Bit Floating Point Value	2	40006-7
PRESSURE	32 Bit Floating Point Value	2	40008-9
RELATIVE HUMIDITY	32 Bit Floating Point Value	2	40010-11
TEMPERATURE	32 Bit Floating Point Value	2	40012-13
DEWPOINT	32 Bit Floating Point Value	2	40014-15
SUPPLY VOLTAGE	32 Bit Floating Point Value	2	40016-17
STATUS	32 Bit Unsigned Integer (UINT)	2	40018-19

MetPak Pro Base Station Output Parameters	Type	No. of Registers	Register Numbers
NODE	4 Bit Character String	2	40001-2
DIRECTION	32 Bit Floating Point Value	2	40003-4
SPEED	32 Bit Floating Point Value	2	40005-6
W AXIS	32 Bit Floating Point Value	2	40007-8
PRESSURE	32 Bit Floating Point Value	2	40009-10
RELATIVE HUMIDITY	32 Bit Floating Point Value	2	40011-12
TEMPERATURE	32 Bit Floating Point Value	2	40013-14
DEWPOINT	32 Bit Floating Point Value	2	40015-16
PRT	32 Bit Floating Point Value	2	40017-18
AN1	32 Bit Floating Point Value	2	40019-20
AN2	32 Bit Floating Point Value	2	40021-22
DIG1	32 Bit Floating Point Value	2	40023-24
SUPPLY VOLTAGE	32 Bit Floating Point Value	2	40025-26
STATUS	32 Bit Unsigned Integer (UINT)	2	40027-28

1. All registers are 16bit.
2. The first byte is high order and the second is low.
3. Each measurement is comprised of two 16bit registers.
4. For all registers, the order of the two data bytes comprising the 16-bit register's value shall be: High Byte/Low Byte.
5. For each 32-bit data type (whether floating point or integer), the order of the first pair of bytes and last pair of bytes shall be: High Word/Low Word.
6. Registers start at address 40001.
7. Holding registers available in the order of the Base Station data string (which can be established by the REPORT command in non-Modbus Gill ASCII Mode).
8. If measurements cannot be computed (i.e. a blank field in Gill mode output string), their Holding Register contents shall be set to the Maximum Positive value (0x7FFFFFFF for 32-bit format data (both floating point and integer), and as 0x7FFF for 16-bit format data).

See Simply Modbus program reading example MetPak Pro Base Station MODBUS Data as follows:-

The screenshot shows the 'Simply Modbus 7.0' application window. The interface is divided into several sections:

- Configuration:** mode (RTU), COM port (1), baud (19200), data bits (8), stop bits (2), parity (none). Slave ID (1), First Register (40001), No. of Regs (26). Function code (3), minus offset (40001), register size (16 bit registers).
- Request:** 01 03 00 00 00 14 45 C5
- Response:** 01 03 38 00 00 00 51 43 9D 80 00 3D B8 51 EB 44 81 A6 66 42 24 CC CD 41 B6 14 7B 41 0E E1 48 41 D0 E1 48 3A 03 12 6E 41 C8 00 00 00 00 00 41
- Register List:** A table with columns for register type, register #, bytes, results, notes, and clear notes.
- Advanced Settings:** High byte/Low byte, High word/Low word, expected response bytes (lrc: 33, 45), send continuously, response time (0.2), pause between sends (30.0), responses (153), failed (0), RTS delay (0).

copy down	register #	bytes	results	notes	clear notes
4chString	40001	0000 0051	Q	NODE	
32bit Float	40003	439D 8000	315.00000	DIR	
32bit Float	40005	3DB8 51EB	0.09000000	SPEED	
32bit Float	40007	4481 A666	1037.2000	PRESS	
32bit Float	40009	4224 C0CD	41.20000	RH	
32bit Float	40011	41B6 147B	22.760000	TEMP	
32bit Float	40013	410E E148	8.930000	DEWPOINT	
32bit Float	40015	41D0 E148	26.110001	PRT	
32bit Float	40017	3A03 126E	5.000000E-4	AN1	
32bit Float	40019	41C8 0000	25.000000	AN2	
32bit Float	40021	0000 0000	0.0000000	DIG1	
32bit Float	40023	4140 0000	12.000000	VOLT	
32bit UINT	40025	0000 0000	0	STATUS	

6.6. Configuring a MetPak Base Station for NMEA Output

Applicable to MetPak Base Station units Part 1723-1A-3-xxx only.

Not applicable to MetPak Pro Base Station.

Connect a default set MetPak Base Station to a PC as described in Para 4.9.

Set unit for NMEA output using MetSet.

Open MetSet as described on Para 6.2 and click on the Reporting page.

Change the Report Format drop down menu from USERDEF to NMEA.

On the Comms Page select the required Interface, generally RS422.

On the Comms Page Select the required Baud rate, normally 4800 bauds (or sometimes 9600 baud).

Click on Save Settings to Device.

Alternatively set for NMEA using a Terminal Program.

Open a Terminal program (such as Tera term/Putty/HyperTerminal).

Place the MetPak into SETUP MODE by Typing the * command.

Type **REPORT NMEA** and press Enter.

Type **BAUD 4800** and press Enter.

Type **COMMS RS422** and press Enter. Until the unit is restarted, the COMMS setting will remain unchanged.

Shut down the MetPak Base Station unit.

Change the hardware connections for RS422 communication.

Restart the MetPak Base Station unit.

Example NMEA data string produced at the output rate (default every 1Hz):-

```
$WIMWV,008,R,000.09,N,A*0C
```

```
$WIXDR,C,+023.0,C,TEMP,P,1.0199,B,PRESS,H,039.6,P,RH*33
```

The NMEA data string comprises of: -

```
$WIMWV,008,R,000.09,N,A*0C,<CR>,<LF>
```

Where: -

\$WIMWV	Wind Instrument Mean Wind direction and Velocity
008	Wind Direction
R	Wind Measurement R elative to the North Marker
000.09	Wind Speed
N	Knots (NMEA output fixed to Knots measurement only)
A	Acceptable measurement (V is a void fail measurement)
0C	Hex CheckSum

And

\$WIXDR,C,+023.0,C,TEMP,P,1.0199,B,PRESS,H,039.6,P,RH*33,<CR><LF>

Cont.

Where: -

\$WIXDR	Wind Instrument Cross track error Dead Reckoning
C	Type of Sensor (Temperature)
+023.0	Temperature Reading
C	Temperature Reading in Degrees Centigrade
TEMP	Name of Temperature Sensor
P	Type of Sensor (Pressure)
1.0199	Pressure Reading in Bars.
B	Pressure Units of Measure (Bars)
PRESS	Name of Pressure Sensor
H	Type of Sensor (Humidity)
039.6	Humidity Reading in Percent
P	Humidity Units of Measure (Percent)
RH	Name of Relative Humidity Sensor
33	Hex CheckSum

<CR> is a Carriage return character (ASCII hex value d)

<LF> is a Line Feed Character (ASCII hex value a)

Checksum, the 2 digit Hex Checksum sum figure is calculated from the Exclusive OR of the bytes between (and not including) the \$ and * characters.

6.7. Safe Mode

The Base Station Range Safe Mode provides a means of recovering communication with the Base Station whatever configuration settings may have been made. For instance if the unit has been set for SDI-12 or Modbus operation Safe Mode can be used to change the communication option back to RS232 , RS422 or RS485 etc.

6.7.1. Safe Mode Method 1

Connect the Base Station for RS232 communication as detailed in Para 4.9.

Open Gill MetSet Software (see Para 6.2).

Click on Connect and Read. MetSet will scan COM port settings for a connected Base Station but as the COMMS protocol is not matched will be unable initially to find the Base Station.

Now Click on the Safe Mode button.

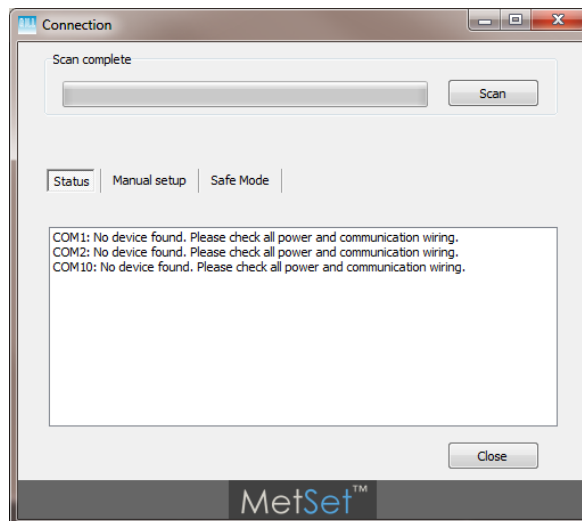

Ensure the Base Station is wired for RS232 operation and power and Click on Next.

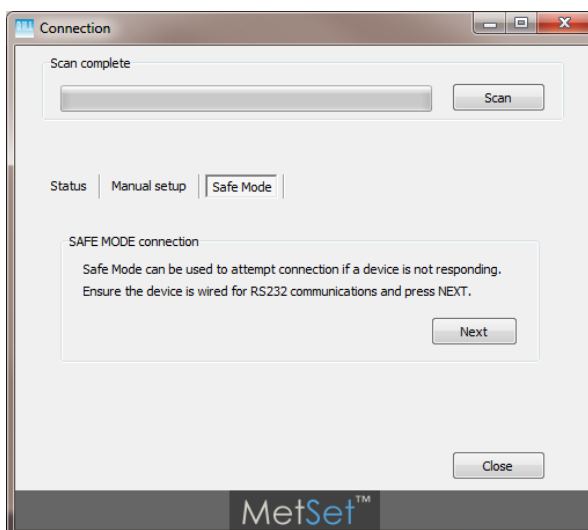

Enter the Base Station COM Port connection number.

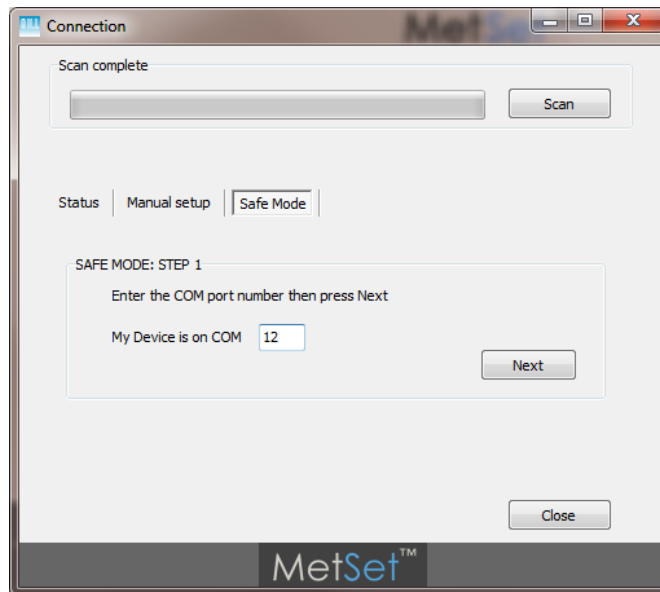

Ensure power is now disconnected from the Base Station.

If using the Gill RS232 to USB configuration lead then unplug the 8 way connector from J5 in the Base Station hub box.

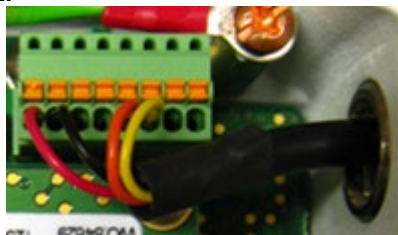

(Do not remove the Gill Configuration lead USB connector from the PC as this will stop Safe Mode being achieved).

Now click on Next.

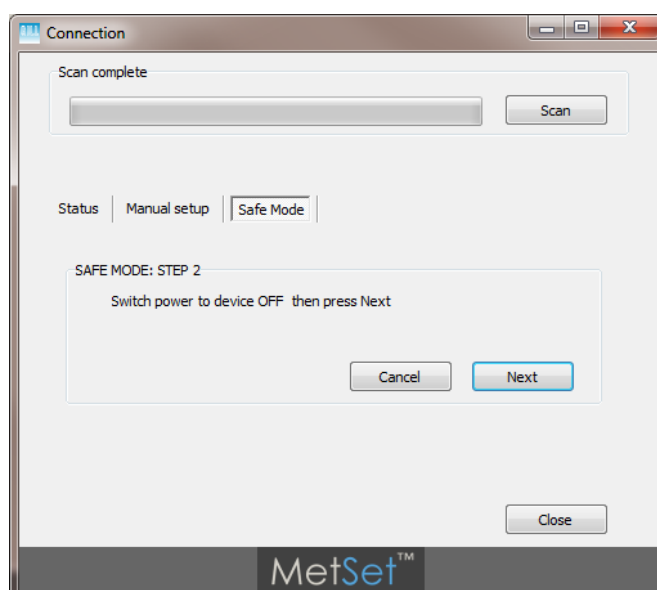

Now re-connect power to the Base Station.

If using the Gill Instrument RS232 to USB configuration cable then plug in the 8 way connector to J5 in the Base Station Hub box.

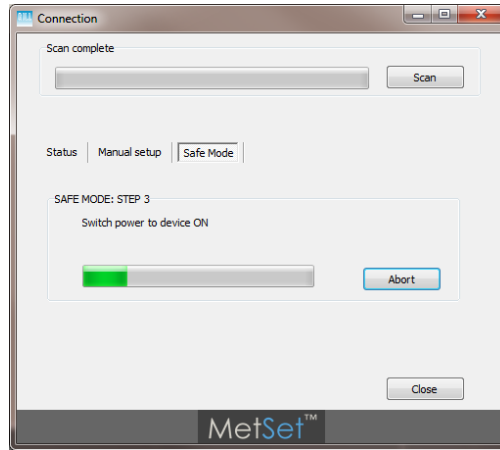

MetSet should now find the Base Station as follows to read settings.

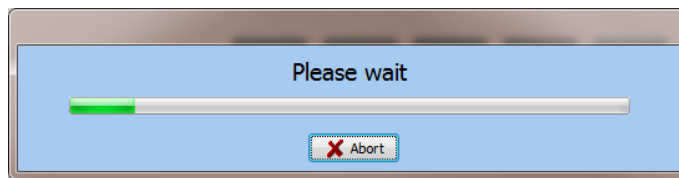

Base Station settings read as follows and reports Comms mode setting as RS485P2W. Click on Close.

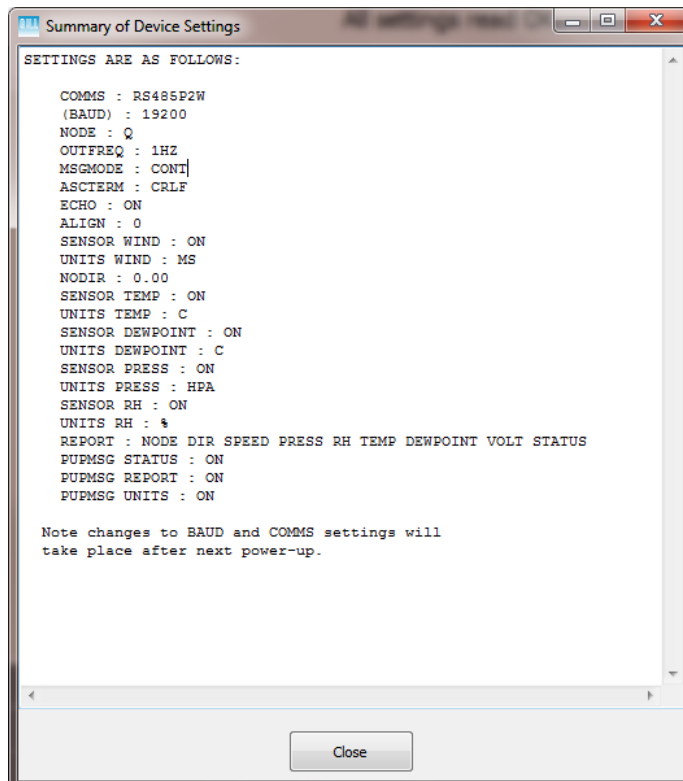

MetSet now opens a Safe Mode 4800 baud connection from which all settings can now be read and changed.

MetSet has detected the Base Station settings in this case Comms were set for RS485, 2 Wire.

Now use the MetSet Interface Menu to make any required changes e.g. change comms back to RS232.

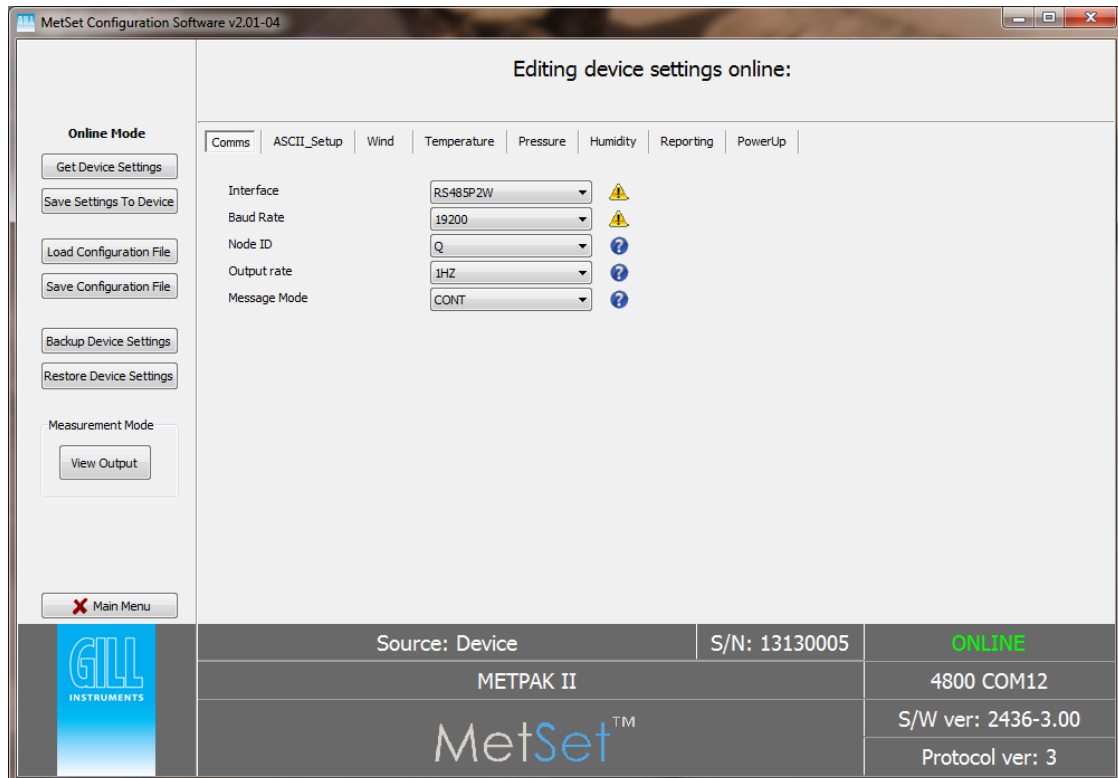

6.7.2. Safe Mode Method 2

Connect the Base Station for RS232 communication as detailed in Para 4.9.

Note at this stage the Base Station supply to be switched off.

Open a Terminal program e.g. Gill WIND Software (obtainable from <http://www.gillinstruments.com/main/software.html>) or equivalent terminal program e.g. Tera-Term, Putty etc.

If using Gill Wind Software note that the Tools features are not applicable.

Open Gill Wind Software.

Serial Port: Set the drop down menu to the required COM Port Connection.

Click on the **OK** button.

Baudrate: Set the drop down menu to **4800** Bauds.

A blank Wind Terminal screen will be opened.

Left Click the mouse in the blank terminal screen.

Hold down the * key on the keypad.

With the * key still held down, apply power to the Base Station.

This will result in placing the unit into SAFE MODE.

Press Enter to start a new line (Ignore illegal command line).

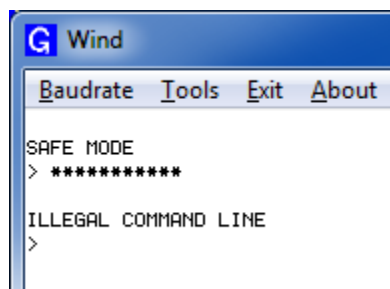

To now change communication from say SDI-12 (or MODBUS) or RS422 or RS485 to Default RS232.

Type **COMMS RS232** and press Enter.

Type **Q** and press Enter to exit SAFE MODE.

Data will now scroll on screen.

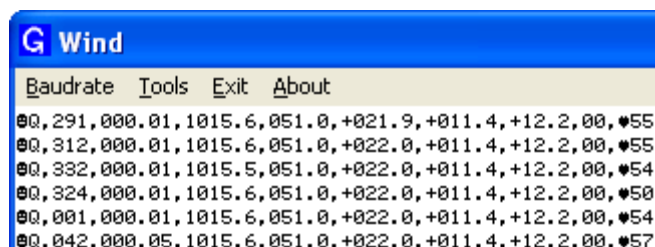

Close the 4800 baud rate Wind or Terminal Program.

Power down the Base Station and re-apply power.

Open a new Wind or Terminal program at **19200** baud rate.

RS232 data will now scroll on screen at the Base Station default 19200-baud rate.

7. VIEWING METPAK BASE STATION DATA

7.1. Use MetView to View the Base Station Data

Gill MetView Software allows you to view the Base Station range data string graphically.

MetView can be downloaded from:-

<http://www.gillinstruments.com/main/software.html>

Before you can use MetView, check that the Base Station is correctly connected to a Serial COM port or USB COM port on your PC.

NOTES: MetView is compatible with RS232 and RS422 connected units only.
MetView will not read SDI-12 or MODBUS data strings.

7.1.1. Opening MetView

Click on the MetView button on your PC's desktop or choose:

Start > Programs > MetView > MetView

The MetView Control Centre window is displayed.

Connect to first device found – Default setting and when selected and Scan operated will connect to the Base Station with the lowest COM port number if multiple Base Stations are connected to the PC COM ports.

Scan Button– If Base Station transmit and receive wires are connected to the PC then use the Scan button to connect to MetView.

Connection is Receive Only Tick Box – Use if the Base Station connection to the PC has only transmit wires connected and a MetSet version of its current device settings is available to upload to MetView. Select 'Connection is Receive only' tick box and click on the Scan button. Upload a MetSet generated Device file from a PC location as directed.

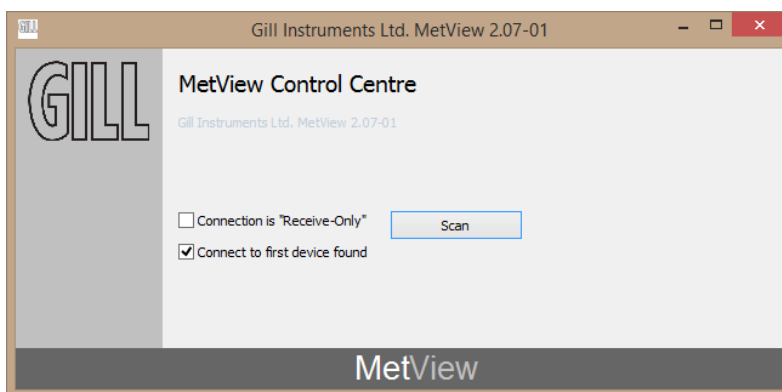

7.1.2. Scanning for Devices

To set up communicate between MetView and a connected Base Station Range unit:-

Click on the **Scan** button to search the available COM ports for Base Station devices.

When a device is found, MetView obtains the Base Station unit configuration settings and then retrieves and displays Base Station data.

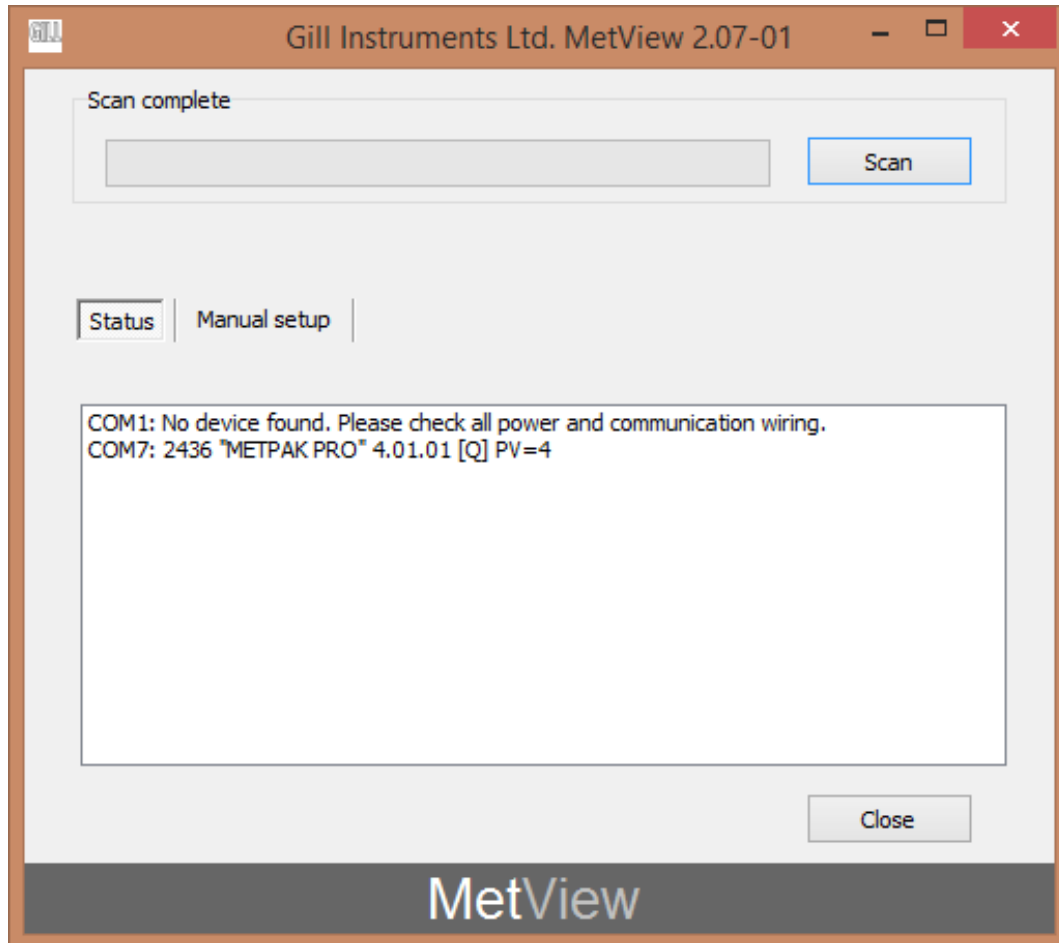

7.1.3. The MetView Console

MetView opens with a data-monitoring console. This consists of gauges showing: the appropriate Base Station parameter which could include Wind Direction, Wind Speed, Pressure, Humidity, Temperature, PRT, Analogue Input 1 and Analogue Input 2. There are also digital readouts of Dew Point and Digital Input 1. Buttons beneath each of the gauges allow you to choose the displayed units and other options. Each gauge also shows the maximum and minimum values recorded during the current session. The wind speed gauge also shows the maximum gust speed.

Note: MetView will not show data if the unit is set for MODBUS or SDI-12 format.

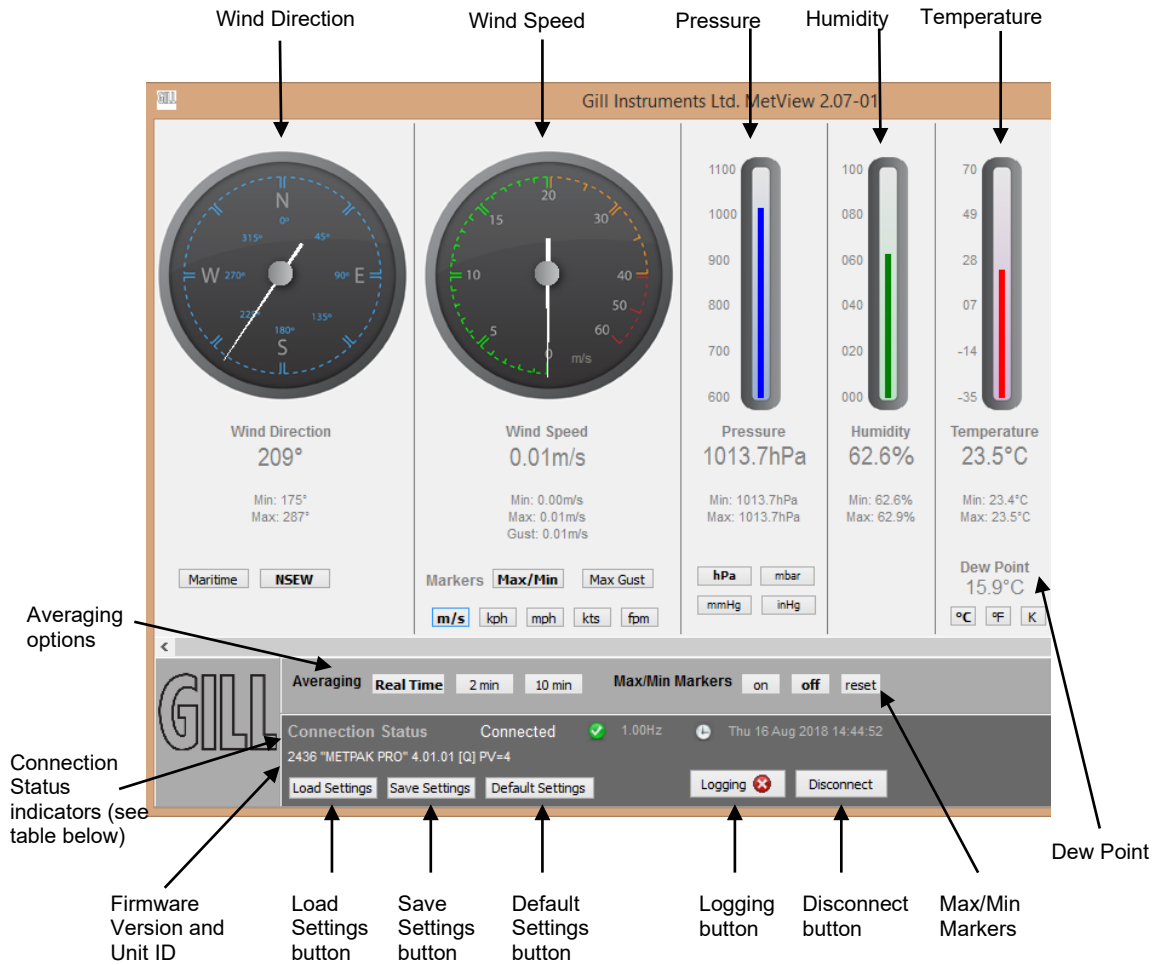

Connection status indicators

Reading	Function
Green Background Tick	Indicates Base Station Unit logging or communicating correctly with MetView along with reading the Base Station firmware version.
Red Background Cross	Indicates Base Station not logging or connected/communicating to MetView.
1.00Hz	Indicates the output rate of the Base Station when connected. Reads when the unit is communicating correctly with MetView.
Thu 16 Aug 2018 14:35:19	Real Time PC date and time indication.

7.1.4. MetPak Pro Base Station User External Sensor Display Example

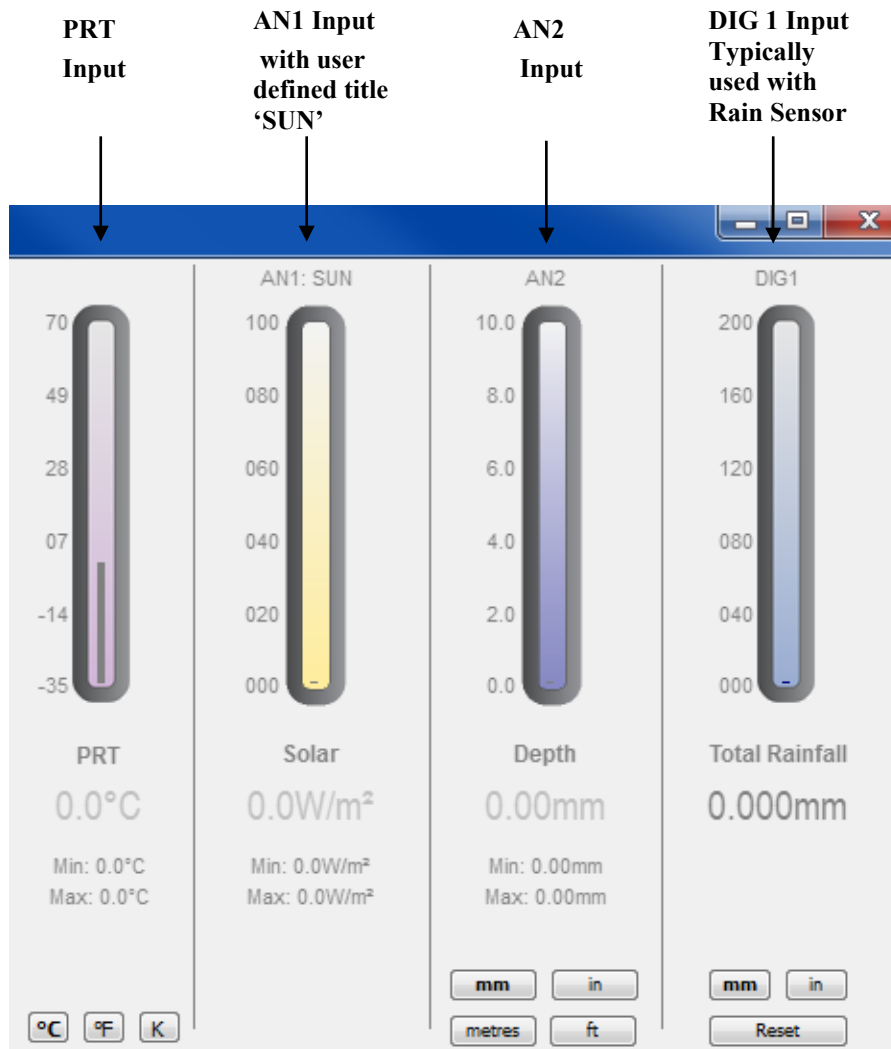

NOTE: The order in which the instruments are shown in the MetView display reflects the order in which the instrument data appears in the Base Station data string.

7.1.5. MetView Console Display Options

MetView Console buttons can convert data from the Base Station unit to read different units or scale settings. This does not alter the actual Base Station unit configuration.

Units shown in **bold** denote default settings.

MetView scale and unit options

Gauge	Function
Wind Direction	Use buttons to choose from two display styles: NSEW or Maritime
Wind Speed Markers	Use buttons to add markers on the gauge for Max/Min or Max Gust.
Wind Speed	Use buttons to choose from five wind speed units: m/s , kph, mph, kts, fpm
Pressure	Use buttons to choose from pressure scales: hPa , mbar, inHg, mmHg
Humidity	Displays Max and Min values during current session in %
Temperature & DewPoint	Use buttons to choose from three temperature scales: °C , °F, K
PRT	Use buttons to choose from three temperature scales: °C , °F, K
AN1	Buttons displayed will depend on Analogue input type selected.
AN2	Buttons displayed will depend on Analogue input type selected.
DIG1	Typically for Rain, reads total rainfall since connected, buttons available for inches or millimetres and a reset button.

MetView averaging options

Setting	Function
Real Time	Choose this button for no averaging
2 Min	Select for 2 minute rolling average of all sensor readings except DIG1
10Min	Select for 10 minute rolling average of all sensor readings except DIG1

Max/min markers

Setting	Function
Off	Maximum and Minimum Markers on all gauges turned off
On	Maximum and Minimum Markers on all gauges turned on
Reset	Reset all Gauge Maximum/Minimum Markers and all digital Maximum/Minimum reading at will

MetView Screen Settings Options

Setting	Function
Save Settings	Will Save all the current MetView screen settings to a file for later retrieval if required.
Load Settings	Will load and update the MetView screen with a previously saved setting.
Default Settings	Will return all MetView screen settings to factory default.

7.1.6. MetView Gauge Ranges and Graphs

Gauge Range Settings.

MetView Pressure, Humidity, Temperature, PRT, AN1 and AN2 Gauge ranges may be altered to view changes in conditions more visibly.

Note, these changes only affect MetView settings and do not affect the Base Station Unit output.

For instance if the typical temperature measurement range required is from +10 degrees to +40 deg C then the temperature gauge range can be adjusted to reflect this.

Place the mouse pointer over the Temperature display gauge and double click to bring up the Set Gauge Range screen. Change Max and Min readings to required values, e.g. +10 min and +40 max.

Click on Set.

The Temperature gauge range will be updated to reflect the change.

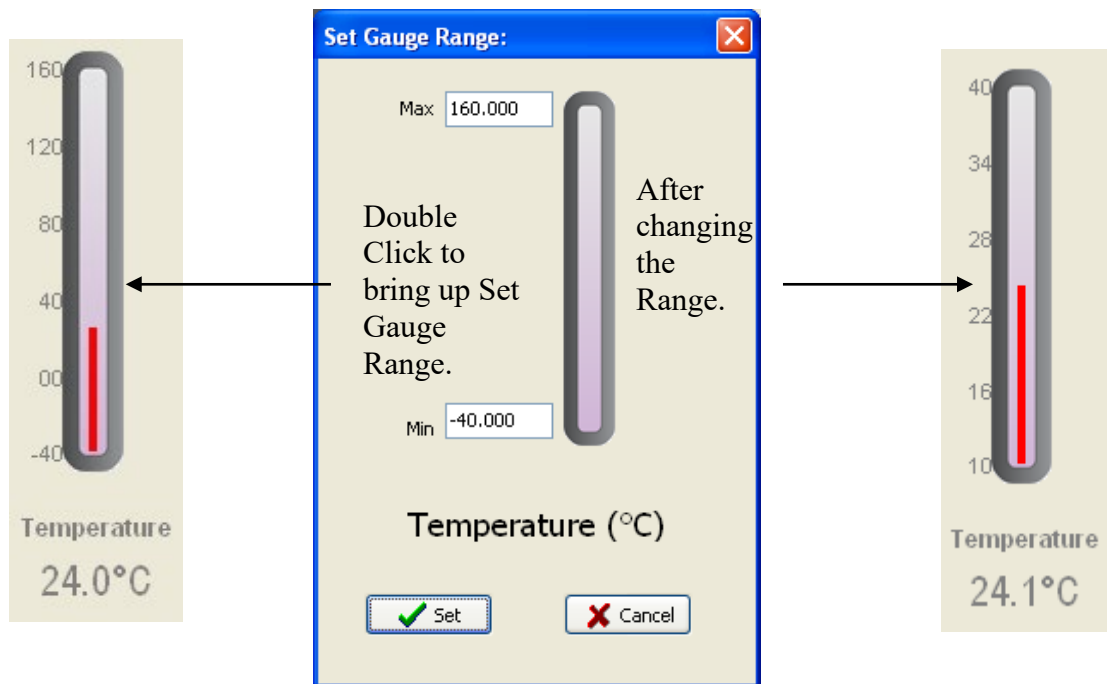

MetView Gauge Range Setting

Graphs

MetView allows data detected over the last minute, last 1 hour and last 24 hours to be accessed and shown on a graph.

Note. Data is only shown up to the time when the graph function is selected; the graph is not updated once opened. Data is collected from the time that MetView is opened and reading data from a Base Station unit.



Double Click on the reading to bring up the graph.

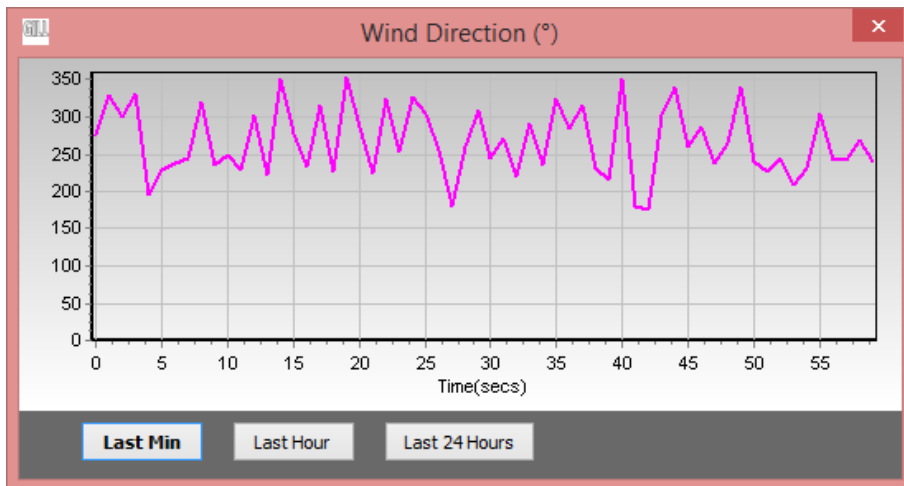

Click on the Last Min, Last Hour or Last 24 Hours buttons as required to view data.

7.1.7. Data logging

NOTE. MetView logs data based on the Base Station configuration not on the MetView console settings.

To log Base Station data, click on the **Logging** button on the MetView console. The *Logging* dialog box is displayed.

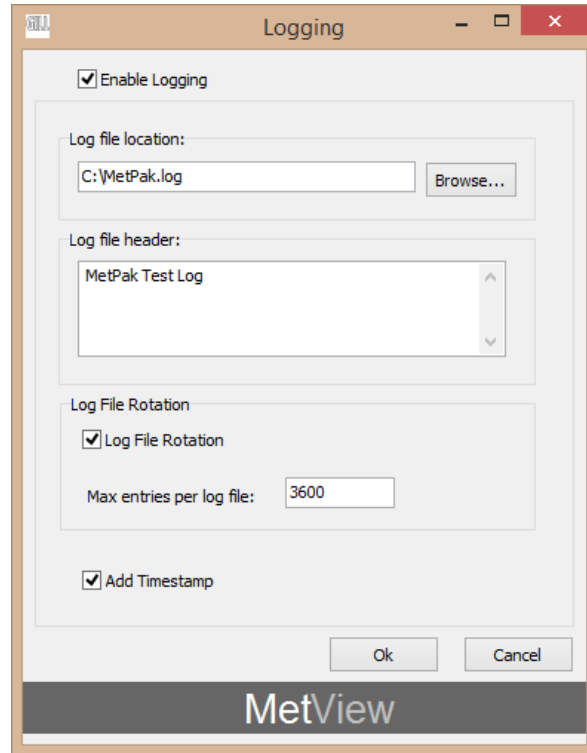

Setting up data logging

Setting up a logging file -

Select **Enable Logging**.

Log File location

Click on the **Browse** button to identify the folder where you want to store the data file. Enter the name of the file.

Log file header

If required type some notes on the data that is to be recorded which will appear at the top of the saved data log file.

Log File Rotation

If required set up segmented logging with each logged file length determined by the number entered in the text box below. The figure 3600, for example, means that each log file length will be 3600 lines of data. Maximum entries per log file is limited to 65535 and a maximum of 2048 log files can be created.

Add Timestamp

Adds the date and time to the logged data file taken from the PC clock.

To start logging



Check that the **Enable Logging** option is selected.

Click on the **OK** button to commence logging and return to the console.

To show that data is being recorded, the Logging button's icon changes to a tick with a green background:

To stop logging



Click on the **Logging** button on the MetView console. Clear the **Enable Logging** check box.

Click on the **OK** button. If logging has stopped, the Logging button shows a red background cross instead of the green background tick (see above).

Example Logged Data

MetView Logged data is stored to a file with a **.log** extension. This can be viewed in any text/HTML editor or spreadsheet application.

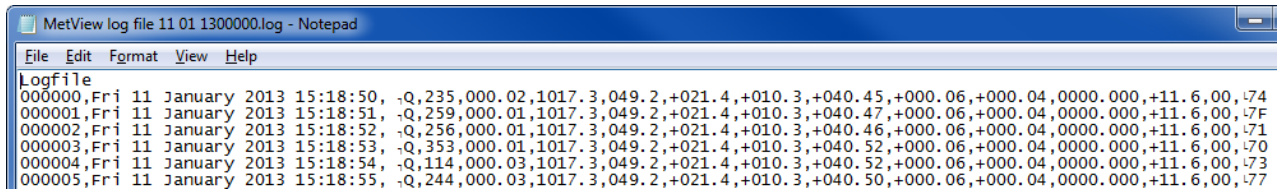

Example MetPak Pro Base Station Data

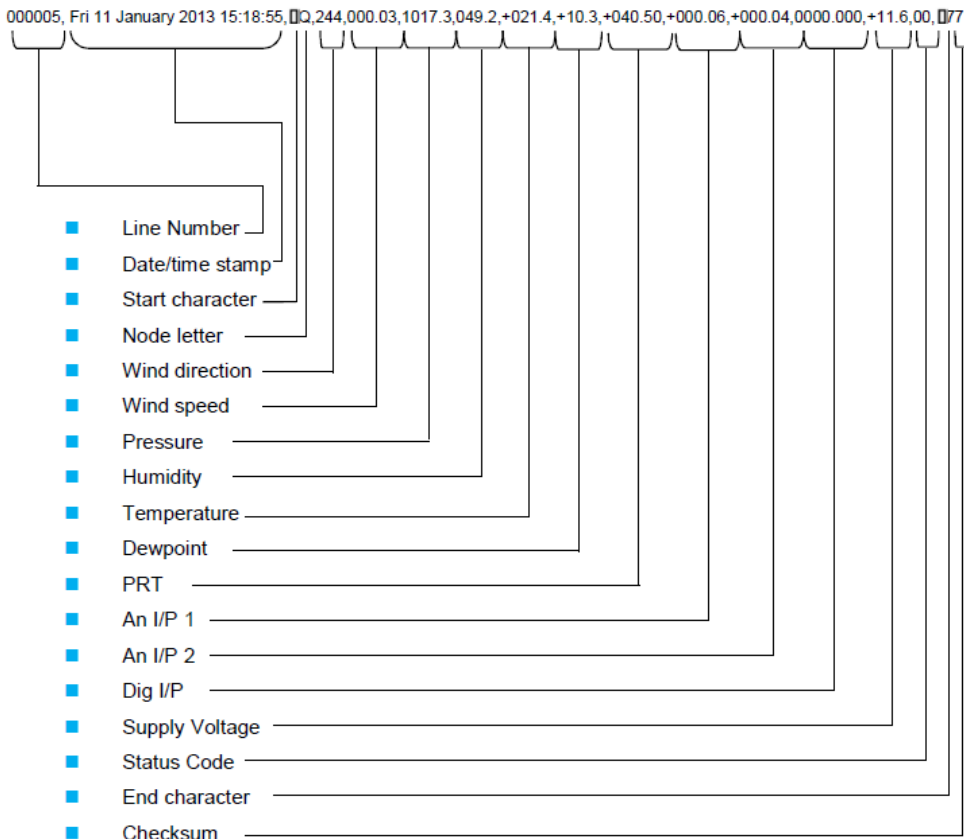

7.2. Use a Terminal Program to View the Base Station Data

There are many terminal programs that might be used to view the Base Station data string examples include: HyperTerminal, Putty, Tera Term etc.

If for example Tera Term is used.

Open Tera Term

Select Serial.

Select the Base Station connected Com port.

Click on Ok.

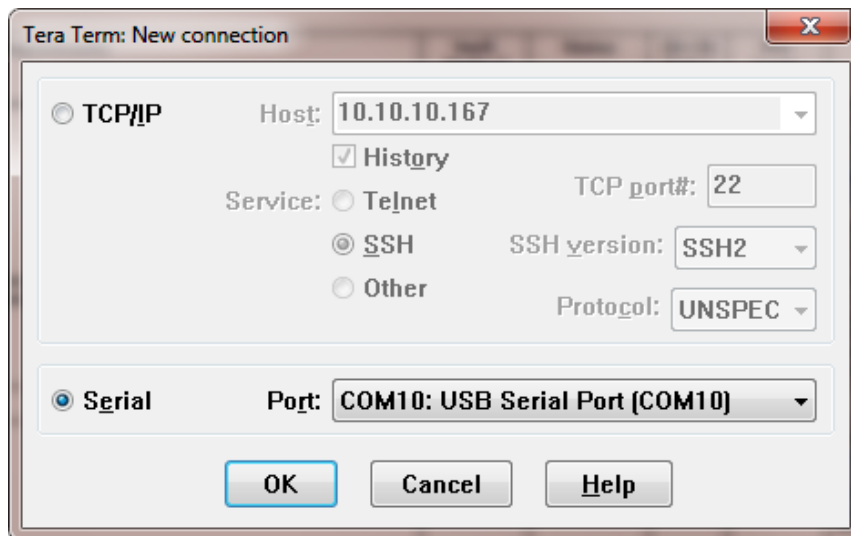

Tera Term has opened at 9600 baud and Base Stations use 19200 baud as a default, so change Tera Term Baud Rate setting to 19200.

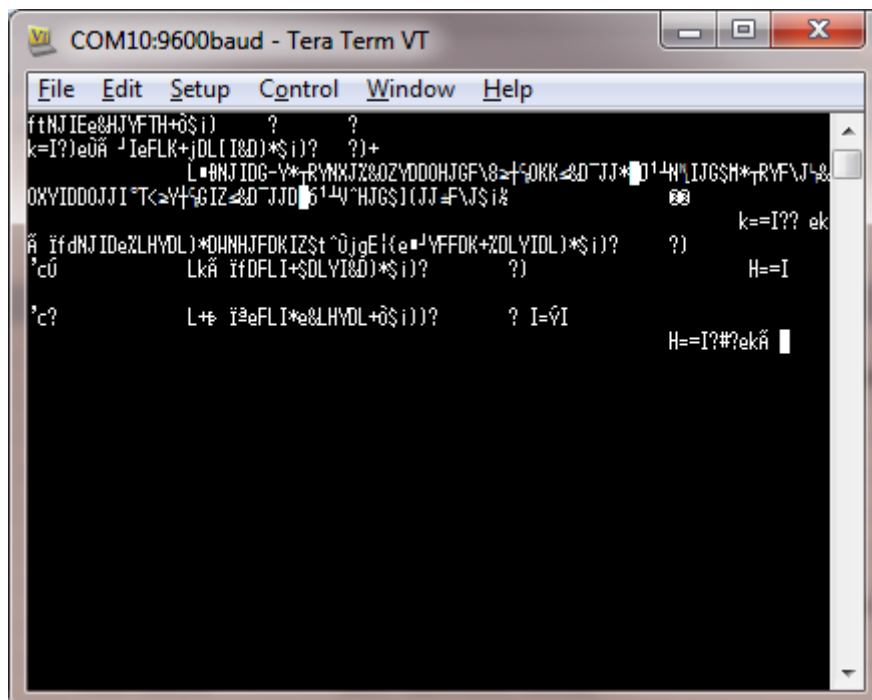

Select Setup from the top menu.

Click on Serial Port from the drop down menu.

Change Baud rate to 19200.

Click on OK.

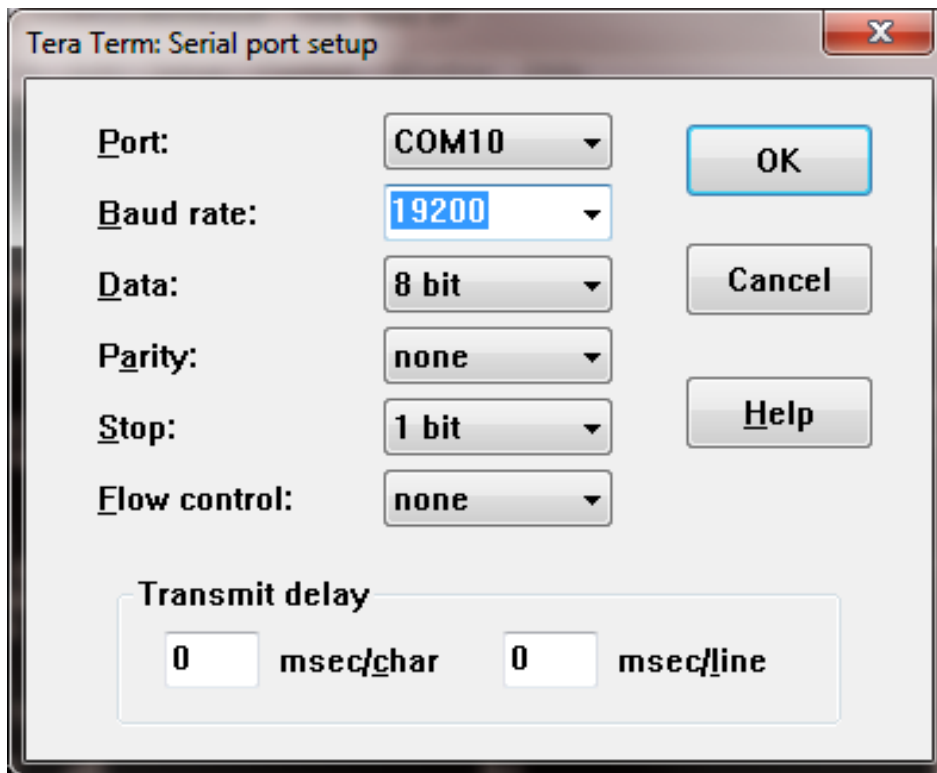

Data will be output as follows.

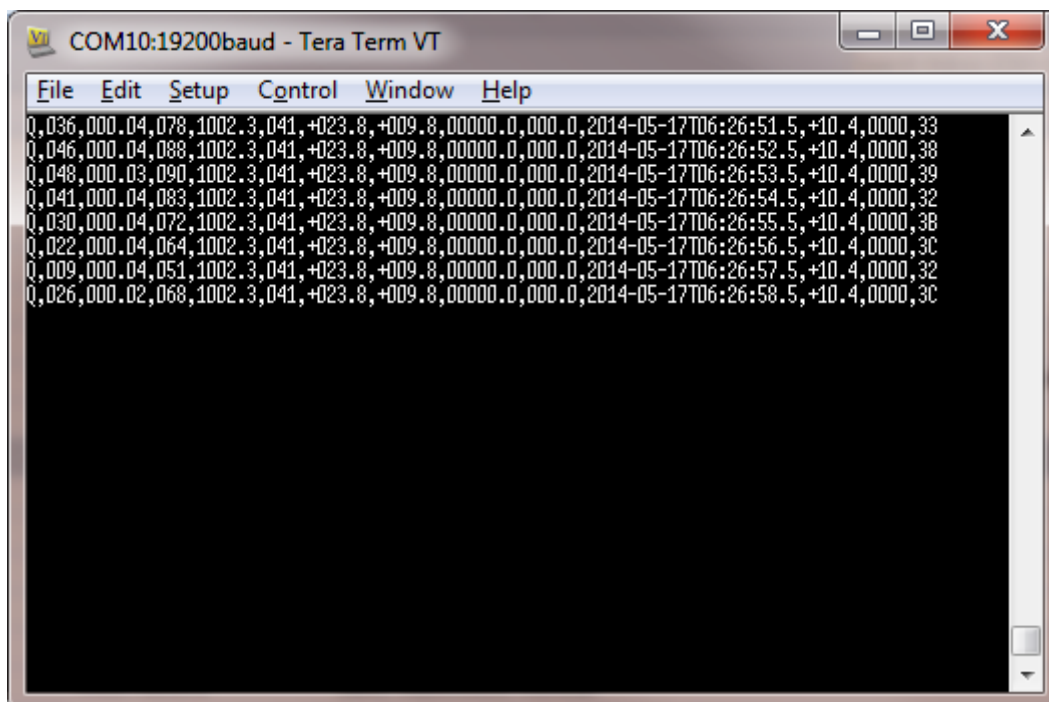

7.2.1. Setting up a logging file

Select **File/Log**.

Look in select a log file location.

Select **Save in** destination. E.g. Desktop.

File Name add the name for the file e.g. Tera Term.

Tick options as required e.g. Timestamp.

Click on **Save**.

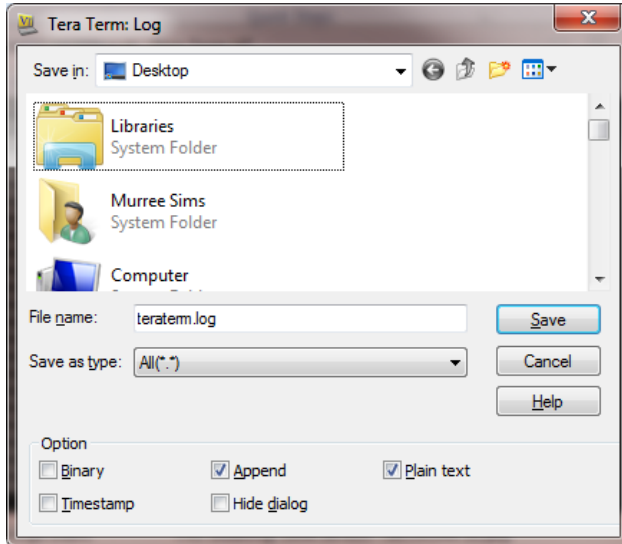

The following dialog box will open on the PC desktop.

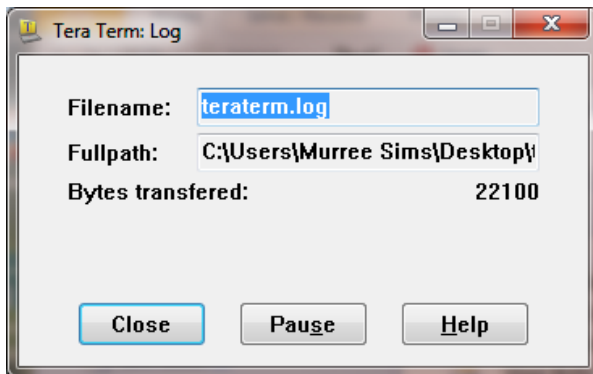

7.2.2. To stop logging

Click on the **Close** button to Stop Logging

Understanding Logged Data

Logged data is stored to a file with a **.log** extension. This can be viewed in any text/HTML editor or spreadsheet application.

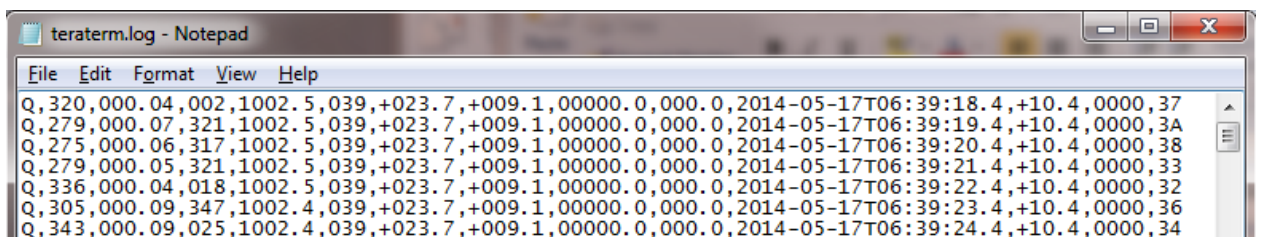

8. MAINTENANCE & FAULT-FINDING

8.1. Cleaning and Handling

Ideally when installing the unit handle with lint free gloves and degrease the unit to reduce the build-up of deposits.

8.2. Servicing

There are in general no moving parts requiring routine maintenance.

In the event of failure, prior to returning the unit to your authorised Gill distributor, it is recommended that:

- All cables and connectors are checked for continuity, bad contacts, corrosion etc.
- A bench test is carried out.
- Contact your supplier for advice if failure persists.
-

8.2.1. Wind Sensors



If there is any build-up of deposits on the unit, it should be gently cleaned with a cloth, moistened with soft detergent. Solvents should not be used, and care should be taken to avoid scratching **any surfaces**. **The unit must be allowed to defrost naturally after being exposed to snow or icy conditions, do NOT attempt to remove ice or snow with a tool.**

There are no moving parts or user-serviceable parts requiring routine maintenance.

Opening the unit or breaking the security seal will void the warranty and the calibration.

8.2.2. UV Radiation Shield (MetSpec)



Ideally the user should try to keep the MetPak Temperature and Humidity housing radiation screens clean and free of biological growth but a simple wipe with some non-aggressive soft detergent cleaner will suffice. Solvents should not be used, and care should be taken to avoid scratching any surfaces. The unit must be allowed to defrost naturally after being exposed to snow or icy conditions, do NOT attempt to remove ice or snow with a tool.

8.2.3. Barometer

The Barometer device is located internally and is not maintainable or replaceable by a user. However, if required observe the following with regard to the central Hub box screw cap Gore-Tex® filter.

Consideration should be given to checking the Pressure readings against a standard every 12 months. If required contact Gill Instruments for advice on checking the Barometer calibration.

Pressure Sensor Filter Replacement:



There is a small venting filter for the pressure sensor of the Base Station range located on the 'Hub' box lid which ensures proper conditions are present in the 'hub' box for pressure measurements without allowing any moisture or other damaging pollutants into the box. This filter is made from Gore-Tex® material and is designed to last a long time without replacement, however, Gill do recommend that this filter is replaced every 24 months to ensure proper operation of the pressure sensor and to keep the electronics inside the 'hub' box dry.

If you do not replace the filter every 24 months you may start to see elevated or erroneous readings of the pressure sensor with time and this behaviour can be corrected by replacement of the Gore-Tex® filter unit.

The Gore-Tex® filter kit is available from:-

Gill Instruments Part Number 1723-PK-024.

To replace the filter, unscrew the 4 screws retaining the hub box lid. Remove the existing Gore-Tex filter and M12 Nut. Fit and secure the new filter with the nut provided. Re-fit the 4 lid screws.

Should you be uncertain as to how often you should be replacing the filters for your application or if you wish to discuss this in more detail please contact Gill support and we will be able to provide a recommendation for you.

8.2.4. Temperature, Humidity and Dewpoint Probe (Rotronic HC2A-S3-GI)



Rotronic Temperature and Humidity Filter Replacement

For extreme environments such as maritime installations, chemical plants or other areas of high pollution or contamination, Gill highly recommend replacement of the temperature and humidity probe filter every 6 months to 12 months to ensure proper performance.

Corroded, discoloured or clogged dust filters should be replaced.

If the filter is not replaced it is very likely you will see elevated humidity levels with time and if this is allowed to develop for a longer period of time it can lead to permanent damage on the electronics of the temperature probe due to the very high moisture content and corrosive effect of the pollutant or salt.

The Rotronics polycarbonate dust filter screw-on cap is available from:-

Gill Instruments	Part Number	1723-PK-027 (2 filters).
Rotronic	Part Number	SPA-PCW-PE (1 filter).

If you need to replace the dust filter cap, carefully unscrew it and withdraw carefully avoiding contact with the Temperature and Humidity circuit board. When re-fitting the filter cap, ensure the circuit board connections are not bent.

Consideration should be given to an annual calibration check of the Hygroclip sensor by the manufacturer.

If you are replacing the whole cartridge, unscrew the metal ferrule and return the probe to Rotronic for calibration. Refer to the Rotronic Website for more details:

NOTE. If you return the sensor to a Hygroclip supplier for exchange, please request that the return unit has the DewPoint feature enabled (HC2A-S3-GI).

8.2.5. Solar Sensor



If a Solar Sensor is used with a MetPak Pro Base Station then Users/Distributors should clean the glass dome with a soft lint free cloth and where necessary with a non-aggressive cleaning solution ideally once a week. Where this is not possible, cleaning should be done during regularly scheduled visits to the sensor and site. It is ideally recommended the solar sensor should be cleaned every month.

8.2.6. Calibration

A calibration check can be done by any user/distributor by comparing the values measured by Base Station with a reference value or in an environmental chamber. Users should understand that these checks are not the same as the calibration checks or calibration done at Gill but they can provide users with some degree of confidence to the validity of their measurements. If a user/distributor notices a significant difference between the Base Station and their test environment/reference they should contact Gill to discuss this and see if a calibration is required. See individual parts above for any recommended calibration periods.

8.2.7. Returning the Base Station

If the unit has to be returned, it should be carefully packed in the original packaging and returned to your authorised Gill distributor, with a full description of the fault condition. An RMA number should be obtained from Gill Instruments first if returning directly to Gill Instruments.

8.3. Fault-finding

8.3.1. Fault Symptoms/Solutions

Symptom	Solution
No output	<p>Check DC power to Base Station, cable and connections.</p> <p>Check communications settings of the Base Station and host system match, including correct Com port.</p> <p>Check that the unit is in Continuous mode.</p> <p>Check that in-line communication devices are wired correctly.</p> <p>NOTE: It is usual for Anemometer TX + to be connected to converter device RX +.</p> <p>If appropriate use Safe Mode to attempt to obtain communication with the Base Station.</p>
Corrupted output	<p>Check that the communication settings of the Base Station and host system match.</p> <p>Try a slower baud rate.</p> <p>Check cable lengths and type of cable.</p> <p>Check for sources of external signal interference.</p>
One way communication	Check that the wiring is in accordance with the manual.
Unexpected Temperature /Dewpoint readings	Check that the Temperature and Dewpoint units of measure (C, F, K) settings are correct on power up.
Unexpected Wind readings	Check that the Wind Sensor units of measure (m/s, knots, kph, ft/min, mph) settings are correct on power up.
Unexpected Temperature/Dewpoint and Humidity readings	Temperature and Humidity Device faulty.
Unexpected Barometer Readings	Check units of measure are set correctly and if offset HASL or PSTN readings have been applied.
Status code not 00 or A	See following Table.

8.3.2. MetPak Base Station Range Sensor Status Codes

Code	Status	Condition
00	OK	No fault conditions detected in measurement period.
A	Acceptable Data (NMEA Mode)	No fault conditions detected in measurement period.
01	Wind Sensor Axis 1 failed	U Axis blocked or faulty.
02	Wind Sensor Axis 2 failed	V Axis blocked or faulty.
04	Wind Sensor Axis 1 and 2 failed	U and V axis blocked or faulty.
08	Wind Sensor NVM error	Non Volatile Memory checksum failed, data could be uncalibrated.
09	Wind Sensor ROM error	Read Only Memory checksum failed, data could be uncalibrated.
0B	Wind Sensor reading failed.	Wind Sensor faulty.
10	Hygroclip error	Hygroclip faulty.
20	Dewpoint error	Hub Pec faulty.
40	Humidity error	Hygroclip faulty.
66	Wind Sensor Power	Check Wind Sensor is powered
67	Wind Sensor RS232 Communications	Check Wind Sensor RS232 wiring
80	Pressure Sensor Warning	Pressure sensor reading not available/unit faulty.
XX	More than one fault	Fault condition that can be the sum of 0B, 10, 20 or 40. e.g. 1B would mean that both the Wind Sensor (0B) and Hygroclip (10) were faulty.
V	Void Data, Wind Sensor reading failed (NMEA mode)	Wind Sensor faulty.

8.4. Safe Mode

If a unit is received that will not communicate or the configuration settings are not known then Safe Mode can be used to establish communication with the Base Station and change configuration settings (see Para 6.7).

8.5. Bench Test

Carry out a bench test as follows:

Connect the Base Station unit to the host PC and power supply, using a known working test cable.

Check for normal output data, and that the Status Code is OK – 00.

If the status code is other than 00, refer to above Table for a list of status (error) codes.

Use an office fan or similar to check that the unit is sensing wind, turning the unit to simulate changing wind direction and to check that both axes are functioning.

Check for output changes in temperature and relative humidity sensor (the fan will also cause small changes in these properties).

8.6. Returning Units

If the unit has to be returned, it should be carefully packed in the original packaging and returned to your authorised Gill distributor, with a full description of the fault condition.

8.7. Guarantee

For terms of guarantee contact your supplier or refer to the Gill Instruments Terms & Conditions here:

<https://gill.group/wp-content/uploads/Gill-Group-Company-Terms-Conditions-of-Sale-9170-0003-Issue-02-March-20...pdf>

Warranty is void if the unit is damaged or broken.

9. APPENDICES

9.1. Glossary & Abbreviations

Item	Meaning
CAL	Calibration
CR	Carriage Return
CRLF	Carriage Return Line Feed
CSV	Comma Separated Variable
ENG	Engineering
ESC	ESCAPE key on keyboard.
ETX	End of string character
fpm	Feet per minute
GND	GrouND
HEX	HEXadecimal
I/P	InPut
IP66	Protection Classification
KPH	Kilometres per Hour
LF	Line Feed
m/s	Metres per second
MAG	MAGnitude - scalar reference to wind speed
MAX	MAXimum
MIN	MINimum
MPH	Miles per Hour
NMEA 0183 (V3)	National Marine Electronics Association
No:	Number
NVM	Non-Volatile Memory
O/P	Output
PC	Personal Computer
PCB	Printed Circuit Board
ROM	Read Only Memory
RS232	Communications standard
RS422	Communications standard
RS485	Communications standard
RX	Receive
RXD	Received Data
S/W	Software
SDI-12	Serial Data Interface
SEC	SECOnd
STX	Start of string character
TERM	TERMIal
TX	Transmit
TXD	Transmitted Data
+VE	Positive
-VE	Negative
WRT	With Respect To