

## GMX531 Compact Weather Station

The MaxiMet range of compact weather stations is designed and manufactured by Gill Instruments. MaxiMet products use reliable, high quality instruments to provide accurate meteorological information in a wide variety of applications.

### GMX531 Features

**Temperature, humidity, pressure.** A combined instrument mounted inside three double louvered, naturally aspirated radiation shields with no moving parts. The results are high performance across each measurement over long periods of time.

**Solar radiation.** An integrated solar radiation sensor/pyranometer. This highly accurate instrument uses a thermal sensor mounted at its base and protected by a single glass dome to record the amount of light in watts per metre<sup>2</sup>. It is widely used in agro-meteorological applications and for monitoring the performance of solar panels.

**Wind.** Wind speed and direction measurements are provided via an ultrasonic sensor and the addition of an electronic compass provides apparent wind measurements. Average speed and direction together with WMO averages and gust data is also provided. Add GPS (optional) to provide true wind and other features.

**Precipitation.** The Kalyx tipping bucket rain gauge supplied provides excellent performance in tropical or heavy convective precipitation locations. The low power Kalyx connects via a 20m cable (included).



TEMP, HUMIDITY & PRESSURE	SOLAR RADIATION	WIND	PARAMETERS
<ul style="list-style-type: none"> <li>Air Pressure / Temperature</li> <li>Relative / Absolute humidity</li> <li>Naturally aspirated UV stable Radiation shield</li> <li>Protection against wind-blown precipitation/dust</li> </ul>	<ul style="list-style-type: none"> <li>Complies with ISO 9060 and WMO Guidelines</li> <li>Output in watts per metre<sup>2</sup></li> <li>180° hemispherical field of view</li> <li>Records sunshine hours</li> <li>Integrated Hukseflux LP02 pyranometer</li> <li>Glass dome</li> </ul>	<ul style="list-style-type: none"> <li>Wind speed &amp; direction</li> <li>Apparent and true wind (with GPS)</li> <li>WMO wind averages and gust</li> <li>Compass</li> </ul>	<ul style="list-style-type: none"> <li>Solar radiation <math>w/m^2</math></li> <li>Sunshine hours <i>hrs</i></li> <li>Solar Noon</li> <li>Temperature °C / °F / °K</li> <li>Relative humidity % Rh, <math>g/m^3</math></li> <li>Barometric pressure hPa, mbar, mm Hg, In Hg</li> <li>Wet bulb temperature °C / °F / °K</li> <li>Absolute humidity <math>g/m^3</math></li> <li>Air density <math>kg/m^3</math></li> <li>Precipitation <i>mm/hr, mm/total, in/hr, in/total</i></li> <li>Wind speed <i>m/s, km/hr, mph, kts, ft/min</i></li> <li>Wind direction °</li> <li>Wind chill °C / °F / °K</li> <li>True/apparent wind</li> <li>Angle of Tilt</li> <li>Outputs <i>RS232, 422, 485 (ASCII), SDI-12, NMEA, MODBUS, Analogue (option)</i></li> </ul>
<b>GPS (OPTION)</b> <ul style="list-style-type: none"> <li>Height above sea level <i>m</i></li> <li>Sunrise/sunset</li> <li>Position of the sun</li> <li>Twilight</li> <li>MSL pressure</li> </ul>			
<b>PRECIPITATION (INPUT)</b> <ul style="list-style-type: none"> <li>0.2mm tip Kaylx rain gauge</li> <li>20m Cable</li> </ul>			

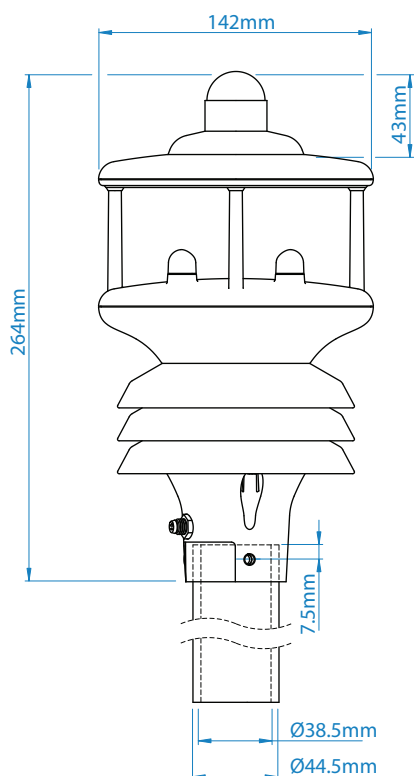

### All MaxiMet Models Feature

- Quality Measurements
- Lightweight and Robust
- Low Power Mode
- Free of Charge Software
- Gill Proven Reliability
- Compact Integrated Design
- Real Time Output
- Easy Installation
- Gill Customer Support
- 2 Year Warranty

\* Please see the manual for a full list of derived parameters

## Kalyx Rain Gauge

The MaxiMet range of compact weather stations is designed and manufactured by Gill Instruments. MaxiMet products use reliable, high quality instruments to provide accurate meteorological information in a wide variety of applications.

### Kalyx Rain Gauge Features

**Precipitation.** The Kalyx tipping bucket rain gauge provides excellent performance in tropical or heavy convective precipitation locations. The low power Kalyx connects via a 20m cable (included) that the user can cut to length.

The sensor has a tipping bucket mechanism which automatically tips when precipitation accumulates inside of it. Total precipitation is determined by the number of tips.

An adjustable mounting plate compensates for uneven surfaces and the unique aerodynamic shape of the rain gauge reduces the effects of wind blown rain being carried away from the collecting vessel.

The tipping bucket includes a drain hole and does not need to be emptied.

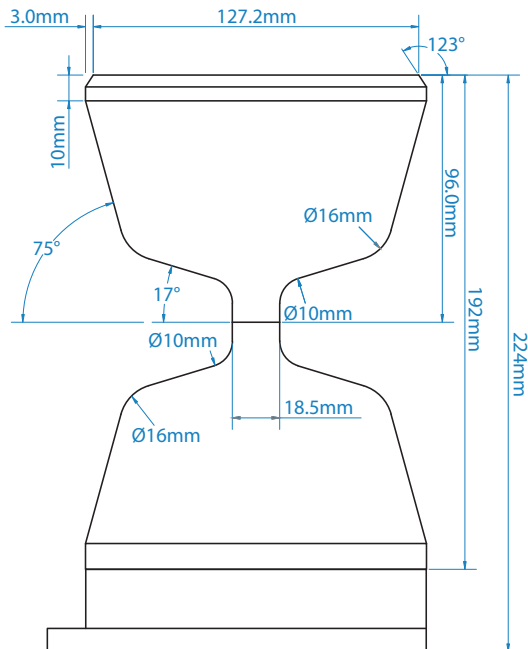

#### SPECIFICATION

Measurement type	TBRG (Kalyx)
Range	0-1000 mm/hr
Precipitation Resolution	0.2 mm
Accuracy	2%
Sampling Rate	1 Hz
Units	mm/hr, mm/total, mm/24 hr, in/hr, in/total, in/24 hr
Heating	N/A
Output	Contact closure via 20m cable to GMX
Mounting	Adjustable mounting plate

## Applications

- Building and Industrial Controls
- Authorities
- Transport
- Coastal
- Agricultural
- Safety
- Educational
- Commercial
- Energy

WIND SPEED	
Range	0.01 m/s to 60 m/s
Accuracy	± 3% to 40 m/s, ± 5% to 60 m/s
Resolution m/s	0.01
Starting Threshold	0.01 m/s
Sampling Rate	1 Hz
Units	m/s, km/hr, mph, kts, ft/min

WIND DIRECTION	
Range	0-360°
Accuracy	± 3° to 40 m/s ± 5° to 60 m/s
Resolution	1°
Starting Threshold	0.05 m/s
Sampling Rate	1 Hz
Units	Degrees

TEMPERATURE	
Range	-40°C to +70°C
Resolution	0.1
Accuracy	± 0.3°C @ 20°C
Sampling Rate	1 Hz
Units	°C, °F, °K

HUMIDITY	
Range	0-100%
Resolution	1%
Accuracy	± 2% @ 20°C (10%-90% RH)
Sampling Rate	1 Hz
Units	% Rh, g/m <sup>3</sup>

DEW POINT	
Range	-40°C to +70°C
Resolution	0.1
Accuracy	± 0.3°C @ 20°C
Units	°C, °F, °K
Sampling Rate	1 Hz

PRESSURE	
Range	300 to 1100 hpa
Resolution	0.1 hPa
Accuracy	± 0.5 hPa @ 25°C
Sampling Rate	1 Hz
Units	hPa, mbar, mmHg, inHg

PRECIPITATION	
Measurement type	TBRG (Kalyx)
Range	0-1000 mm/hr
Precipitation Resolution	0.2 mm
Accuracy	2%
Sampling Rate	1 Hz
Units	mm/hr, mm/total, in/hr, in/total
Heating	N/A
Output	Contact closure via 20m cable to GMX

GLOBAL SOLAR RADIATION	
Wavelength Sensitivity	300 to 3000 nm
Output Range	0 to 1600 W/m <sup>2</sup>
Resolution	1 w/m <sup>2</sup>
DIN Standard	ISO 9060 Second Class
Sampling Rate	1 Hz
Units	w/m <sup>2</sup>

OUTPUTS	
Output rate	1/s, 1/min, 1/hr
Digital Comms Modes	Serial RS232, RS422, RS485, SDI-12, NMEA, MODBUS, ASCII
Analogue Outputs	Available via separate optional device

POWER	
Power Supply	5 to 30 Vdc
Power (Nominal) 12 Vdc	25mA continuous high mode. 0.7mA eco-power mode (1 hour polled)

ENVIRONMENTAL CONDITIONS	
IP Rating	66
Operational Temperature Range:	-35°C to +70°C
EMC Standard:	BS EN 61326-2-1:2013 FCC, CFR Title 47, Part 15, Subpart B, Class A digital device
CE Marking	YES
RoHS compliant	YES
Weight	0.8 Kg (+ 1.2 kg Rain Gauge inc Cable)
Origin	UK

Specifications may be subject to change without prior notice



### Gill Instruments Limited

Saltmarsh Park, 67 Gosport Street  
Lymington, Hampshire SO41 9EG  
United Kingdom

Tel: +44 (0) 1590 613 500

contact@gillinstruments.com

[gillinstruments.com](http://gillinstruments.com)

1957-012 Iss 8

Copyright © Gill Instruments 2022

Gill Instruments Limited, Reg No. 2281574  
Registered Office: Towngate House, 2-8 Parkstone Road, Poole. BH15 2PW