

WindObserver™ 65

Ultrasonic Anemometer

User Manual

(Part Numbers 1390-65-X-XXX)



Table of Contents

1. Welcome to the WindObserver manual.....	4
About this manual	4
1.1. Overview of Content	4
1.2. Description of Icons.....	4
1.3. General Notes.....	5
1.4. User Manual Revision History	5
2. Product Overview.....	6
3. Pre-Installation.....	6
3.1. Equipment supplied.....	6
3.2. WindObserver 65 Part Numbers	6
3.3. WindObserver Accessories.....	7
3.4. WindObserver FCC.....	7
3.5. Right to change and revise	8
3.6. Packaging.....	8
3.7. WindObserver Specification	8
3.8. WindObserver Standard Equipment	8
3.9. Downloadable Software	8
4. Requirements & Installation.....	9
4.1. Requirements.....	9
4.2. Installation.....	10
4.3. Installation Guidelines	10
4.4. Bench system test.....	11
4.5. Cabling	11
4.6. Power supplies.....	12
4.7. Mechanical Installation	13
5. Message Formats & Options.....	24
5.1. Wind Speed format	24
5.2. Output format	24
5.3. Units.....	25
5.4. Output rate.....	25
5.5. Averaging (Digital Data).....	26
5.5.1. G Command Averaging.....	26
5.5.2. Road Weather Averaging (RWA)	26

Ultrasonic Anemometer

5.6.	Options	30
5.7.	ASCII message format (UV, Polar and Tunnel)	31
5.8.	Binary message format (UV,Polar and Tunnel)	34
5.9.	NMEA Format	36
5.10.	Averaging Format (Modes 14 and 15).....	37
Appendix A - Technical Specification.....		38
Appendix B - Connector and Cable Assembly		40
Appendix C - Connections and default setup.....		43
Appendix D - Networking		47
Appendix E - WindObserver 65 Safe Mode.....		49
Appendix F - Configuring.....		50
Appendix G - WindObserver 65 ASCII Data Output.....		58
Appendix H - WindObserver 65 NMEA 0183 Data Output.....		59
Appendix I - Polled Mode Commands.....		60
Appendix J - WindView Software		61
Appendix K - WindObserver 65 Status Codes		66
Appendix L - Maintenance & Fault-Finding.....		67
Appendix M - Glossary & Abbreviations.....		70
Appendix N - Guarantee & FCC		72
Appendix O - Principle of operation.....		73

1. Welcome to the WindObserver manual.

About this manual

This manual provides the information needed to get the best results from WindObserver 65.

The most recent version of this manual is available at gillinstruments.com.

Please read this manual before setting up and installing WindObserver 65.



1.1. Overview of Content

The manual is split into 5 chapters. Each chapter represents an activity in the use of the product. Additional detailed information is contained in the Appendices at the end of the manual.

- Chapter 1 explains how the manual is set out
- Chapter 2 provides a brief overview of the product
- Chapter 3 provides the information needed to Pre-install the product
- Chapter 4 explains the requirements & installation of the product
- Chapter 5 explains message formats & options for the product

1.2. Description of Icons

The following icons are used in this manual.

Icon	Description
	A note that is important and that should be observed
	Information or a recommendation to ensure best results
	The start of a set of instructions

Ultrasonic Anemometer

1.3. General Notes



Before WindObserver 65 is used for the first time it is essential to read and understand this manual. Please keep the manual safe for future reference.



Care should be taken with WindObserver 65 at all times. The product should be transported to site in the box, and only removed when ready to install.



During installation WindObserver 65 should be supported and care should be taken not to drop the product



Care should be taken when wiring the WindObserver 65 to power and communications.



Maintenance should be limited to the procedures described in this manual. Additional maintenance or cleaning may damage the sensors.



No attempt should be made to repair any of the parts of the product. Any attempt to do so will invalidate the warranty provided by Gill Instruments.

1.4. User Manual Revision History

Document Version	Release Date	Key Changes
Iss 8	Oct 2022	New manual template.

Ultrasonic Anemometer

2. Product Overview

The Gill WindObserver 65 wind sensor is a very robust unit with no moving parts, outputting wind speed and direction. The units of wind speed, output rate and formats are all user selectable.

The WindObserver 65 is available with or without de-icing heating (recommended if icing is likely),

The WindObserver 65 can be used in conjunction with a PC, data logger or other device, provided it is compatible with the RS422 output, Multiple units can be networked if required.

Alternatively, the WindObserver 65 is designed to connect directly to the Gill WindDisplay unit to provide a complete wind speed direction system.

The output message format can be configured in Polar, UV (2-axis), NMEA (0183 Version 3), Tunnel formats, and as either a Continuous output or Polled (requested by host system), detailed in full in Section 5 Message Formats & Options.

3. Pre-Installation

3.1. Equipment supplied

WindObserver 65 and Installation kit, 1390-10-163 (see appendix B)

3.2. WindObserver 65 Part Numbers

Available parts are as detailed below: -

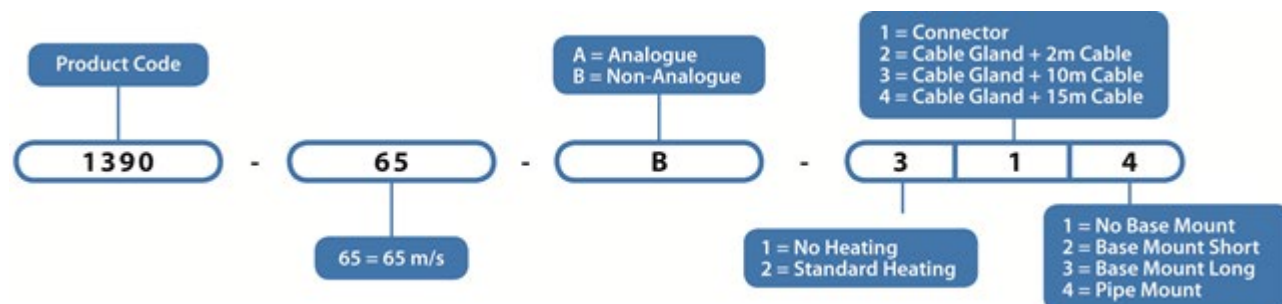

Ultrasonic Anemometer

3.3. WindObserver Accessories

Item	Part Number
Cable 3 Pair twisted and Shielded wires, 24awg, per metre.	026-02660
Cable 4 Pair twisted and Shielded wires, 24awg, per metre.	026-03156
Cable 9 Pair twisted and Shielded wires, 22awg, per metre.	026-02663
Integrity Check Chamber	1277-00-052
19-way Connector kit	1390-10-163
Base Mount Short	1390-30-154
Base Mount Long	1390-30-155
Pipe Mount	1390-30-156
Gill Bracket Mounting Adaptors	1771-PK-116

After you have successfully set up the WindObserver 65, we strongly advise that you then go back and read the rest of the manual to ensure that you get the best results from the WindObserver 65.

3.4. WindObserver FCC

This product carries the CE and UKCA marks. A copy of the Declaration of Conformity can be downloaded from www.gillinstruments.com.

WindObserver 65 complies with part 15 of the FCC Rules. Operation is subject to the following two conditions: -

- (1) This device may not cause harmful interference, and
- (2) This device must accept any interference received, including interference that may cause undesired operation.

This equipment has been tested and found to comply with the limits for a Class A digital device, pursuant to part 15 of the FCC Rules. These limits are designed to provide reasonable protection against harmful interference when the equipment is operated in a commercial environment. This equipment generates, uses, and can radiate radio frequency energy and, if not installed and used in accordance with the instruction manual, may cause harmful interference to radio communications. Operation of this equipment in a residential area is likely to cause harmful interference in which case the user will be required to correct the interference at his own expense.

Ultrasonic Anemometer

3.5. Right to change and revise

Gill Instruments reserve the right to change or revise the product without notice or the obligation to notify any person or organisation of such change or revision.

Gill Instruments reserve the right to change or revise the information supplied in this manual without notice or the obligation to notify any person or organisation of such change or revision.

The reproduction and distribution of the documentation and software supplied with this product and the use of its contents is subject to written authorization from Gill Instruments.

3.6. Packaging

Whilst the WindObserver 65 is being moved to its installation site, the unit should be kept in its packaging. Retain the packaging for use if the unit must be moved or returned to Gill Instruments.

3.7. WindObserver Specification

The WindObserver Specification can be found in Appendix A

3.8. WindObserver Standard Equipment

WindObserver 65 is supplied with:

- Mounting kit & gasket
- Connector kit (if connector base option ordered)
- Base mount (if Base mount option ordered)

3.9. Downloadable Software

Two software packages are available to help customers use the WindObserver 65:

- Wind – this software can be used as a terminal program to set-up the product.
- WindView – this software can be used to view and log data provided by the product.

Both software packages can be downloaded from www.gillinstruments.com

Ultrasonic Anemometer

4. Requirements & Installation

4.1. Requirements



a

Host system - One of the following:

- PC with an internal or external interface compatible with the RS422 output from the WindObserver 65.
 - Gill WindDisplay.
 - Other equipment with I/O compatibility to the WindObserver 65 option selected.
For example if the unit has Digital outputs, a Data Logger, Chart Recorder, or PC fitted with an ADC card.
- Networking - Multiple WindObserver 65 units can be networked.

Software - One of the following:

- Gill Wind Software used as a Terminal program only (Wizard and Sync Comms not applicable). Wind will run on PC's up to and including Windows 11 and can be downloaded free from:-
<http://www.gillinstruments.com/main/software.html>
- TeraTerm or PuTTY.
- Other Terminal Emulation software packages.

Cable and Junctions Box

To connect between the WindObserver 65 and the host system. The unit is supplied with a base mounted connector system or flying cable options (requiring a mast mounted junction box (not provided)) for onward connection. If using a flying cable option it must be retained with a cable tie within 150mm of the base of the anemometer.

Mounting Bracket

The WindObserver 65 can be supplied with a short or long base mount to use with a mounting adaptors. The WindObserver 65 can be attached to the bracket via the four tapped holes in the base mount fitted to the unit. The gasket supplied can be fitted between the sensor and its mounting bracket when it is important to minimise the effects of corrosion should two dissimilar metals be used.

In the event that the mounting bracket supplied by the customer is not flat or does not form complete support for the anemometer base; the customer must fit a mounting ring as shown in Figure 2a.

Mounting Pole

The WindObserver 65 can be supplied with a pole mount that provides the option to attach to a pole with or without a thread (pole not provided). The WindObserver 65 can be retained to the pole via the three tapped holes in the pole mount fitted to the unit.

Ultrasonic Anemometer



4.2. Installation

Do NOT remove the black “rubber” transducer caps. Warranty is void if the green security seal is damaged or removed.

Take care not to knock the four Transducer arms. All the time the WindObserver 65 is not in its final location, it should be protected from damage by keeping it in the original packaging as long as possible, treating it as a delicate instrument.

If an Intrinsically Safe (IS) device is required, the I.S. WindObserver must be used - the WindObserver 65 is NOT an IS device.

Warranty is void if the unit case is removed.

When selecting a site three attributes need to be considered:

- Physical location and obstructions
- Distance from the power supply and data collection system
- EMC interference

4.3. Installation Guidelines

The WindObserver 65 has been designed to meet and exceed the stringent standards listed in its specification.

Operating in diverse environments all over the world, WindObserver 65 requires no calibration or adjustment whatsoever.

As with any sophisticated electronics, good engineering practice should be followed to ensure correct operation.

- Always check the installation to ensure the WindObserver 65 is not affected by other equipment operating locally, which may not conform to current standards, e.g., radio/radar transmitters, boat engines, generators etc.
- Guidelines –
- Avoid mounting in the plane of any radar scanner – a vertical separation of at least 2m should be achieved.
 - Radio transmitting antennas, the following minimum separations (all round) are suggested
 - VHF IMM – 1m
 - MF/HF – 5m
 - Satcom – 5m (avoid likely lines of sight)
 - Ensure the product is correctly earthed in accordance with this manual
 - Use cables recommended by Gill, keeping the length below the maximum allowed (*See Section 4.5*) Where the cables are cut and re-connected (junction boxes, plugs and sockets) the cable screen integrity must be maintained, to prevent the EMC performance being compromised.
 - Earth loops should not be created – earth the system in accordance with the installation guidelines. (*See Connections Appendix C*)
 - Ensure the power supply operates to the WindObserver 65 specification at all times.

Avoid turbulence caused by surrounding structures that will affect the accuracy of the WindObserver 65 such as trees, masts and buildings. The World Meteorological Organisation makes the following recommendation:

- The standard exposure of wind instruments over level open terrain is 10m above the ground. Open terrain is defined as an area where the distance between the sensor and any obstruction is at least 10 times the height of the obstruction.

When installing the unit degrease the unit and hold with lint free gloves to reduce the build-up of deposits.

Ultrasonic Anemometer

4.4. Bench system test

 Prior to physically mounting the WindObserver 65 in its final location, we strongly recommend that a bench system test be carried out to confirm the system is configured correctly, is fully functional and electrically compatible with the selected host system and cabling (preferably utilising the final cable length). The required data format, units, output rate, and other options should also all be configured at this stage. If an Integrity Check Chamber (ICC) has been purchased refer to Section 10.6.

4.5. Cabling

A RS422 compatible cable should be used, with the number of twisted pairs matching the application.

Generic description – Twisted pairs with drain wire, screened with aluminised tape, with an overall PVC sheath. E.g., wire size 7/0.2mm (24 AWG).

The table shows some suitable manufacturers' references; other manufacture's equivalents can be used.

Table 1

No. of Pairs	Gill ref.	Belden ref.	Batt electronics ref.	Cable Gauge
2	-	9729	91071	24
3	026-02660	9730	91030	24
4	026-03156	9728	91199	24
6	-	8778	91011	22
9	026-02663	8774	91009	22

Cable length

The typical maximum length at 9600 baud is 1km (3200ft), using the recommended cable. If any problems of data corruption are experienced (due to, for example, a high local electrical 'noise' level), then a lower baud rate should be used. Alternatively, a thicker or higher specification cable can be tried. If a heated unit is used on longer cables than supplied, consideration should be given to powering the heater using lower gauge wire or paralleling wires to reduce volt drops.

Ultrasonic Anemometer

Cabling and junction box

If the WindObserver 65 unit is fitted with a flying 9 pair cable attached this must be terminated in a suitable terminal box to IP66 or better, fitted with glands to prevent moisture ingress.

The cable type from the terminal box to the host system must be as specified above. If any cable is to be exposed to mechanical damage, it must be enclosed in a suitable conduit or cable tray. The cable must be securely fixed with cable clamps or equivalent at regular intervals such that the WindObserver cable gland does not support the cable weight.

The gland area at the base of the WindObserver 65 **should not** be directly exposed to moisture, as whilst the gland is sealed when mated, the anemometer is vented to air at the base to avoid pressure build up. If an IP66 rating is essential or the unit is mounted other than 'right way up' **use the gasket** provided in the mounting kit and apply additional sealing compounds around the base.

4.6. Power supplies

All WindObserver 65 units

Sensor Supply: -

Voltage 9 to 30v DC

Current 30mA Average. 50mA Max @12v dc

- The WindObserver 65 has reverse polarity protection.

Wind Observer Units with Heating

Heater Supply: -

Voltage 22V to 30V (max) AC RMS or DC.

Current allow for 3A.



The AC Supply must be isolated from Mains Supply.

- The heating module requires a separate power supply.
- Heater Cable length should be minimised to avoid cable volt drops and ensure maximum voltage received at the Anemometer.
- The heating (H command) is enabled as a default condition. If heating is not required enabled, then the H command must be set for H1.
- Each transducer is heated independently and will be enabled when ambient temperature drops below the activation temperature and disabled when the target temperature is reached.

The WindObserver 65 has reverse polarity protection.

Ultrasonic Anemometer

4.7.Mechanical Installation



Do NOT remove the black “rubber” transducer caps.

Take care not to knock the four Transducer arms.

Before installing, a bench system test is recommended.

All the time the WindObserver 65 is not in its final location, it should be protected from damage by keeping it in the original packaging as long as possible, treating it as a delicate instrument.

When installing the unit handle with lint free gloves and degrease the unit to reduce the build-up of deposits.

Do not apply clamps to the WindObserver cylinder body as this will distort the cylinder and affect sealing.

Location

It is important to ensure that the WindObserver 65 is mounted in a position clear of any structure, which may obstruct the airflow or induce turbulence.

Do NOT mount the WindObserver 65 in close proximity of high-powered radar or radio transmitters. A site survey may be required if there is any doubt about the strength of external electrical noise. *(See Section 5.3)*

Orientation

Normally the WindObserver 65 is mounted vertically with the cable exit at the bottom.

Alternatively, the unit may be mounted in any orientation, but note that if the unit is mounted with the cable uppermost, the base **must** be fully sealed externally to prevent water penetration. Fit the supplied gasket if the 2 metal mounting faces are of dissimilar metals to prevent galvanic corrosion.

Ultrasonic Anemometer

WindObserver Sensor and Bracket Mounting

Mount the Sensor on to the Bracket so that the Sensor North Marker points to the bracket pole.

Secure the sensor to its mount using the three M5 screws and three M5 split wavy washers supplied in the mounting bracket kit box. Torque the three M5 bolts and washers to 4.5Nm.

The Bracket uses a mounting clamp suitable for attaching to a vertical pipe with a diameter of 30-58mm. When mounting the Bracket Sensor, consider the position, orientation and alignment of the unit. Mount at the top of a Pipe to ensure a clear unobstructed measurement view.

Note that the mounting pipe should first be degreased and when assembling the Bracket clamp assembly, the outer clamp nuts need to be tightened evenly to a torque figure of 3Nm.

The moving plate part of the clamp needs to be reversed for poles below 38mm diameter.

Screw an Earth cable minimum of 6mm² to the Bracket chassis using Screw and Terminal Tag fixings supplied.

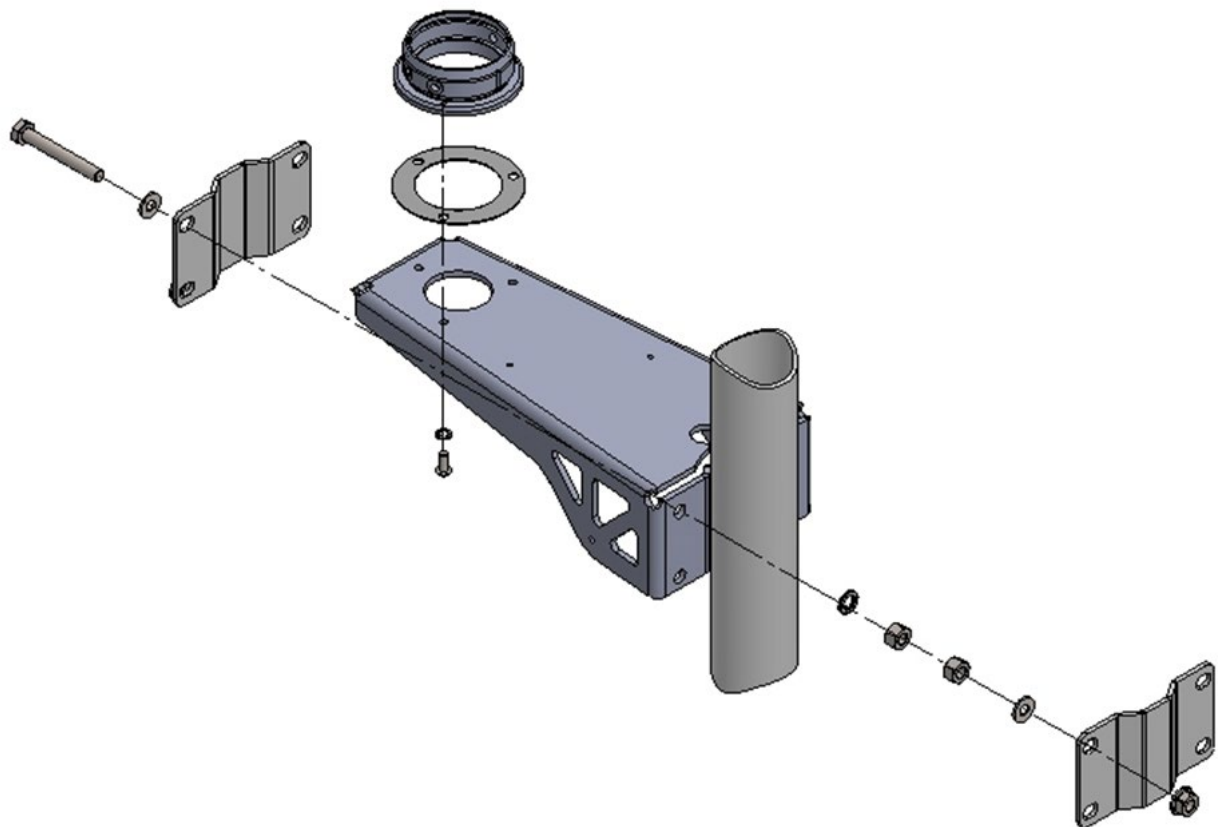

Ultrasonic Anemometer

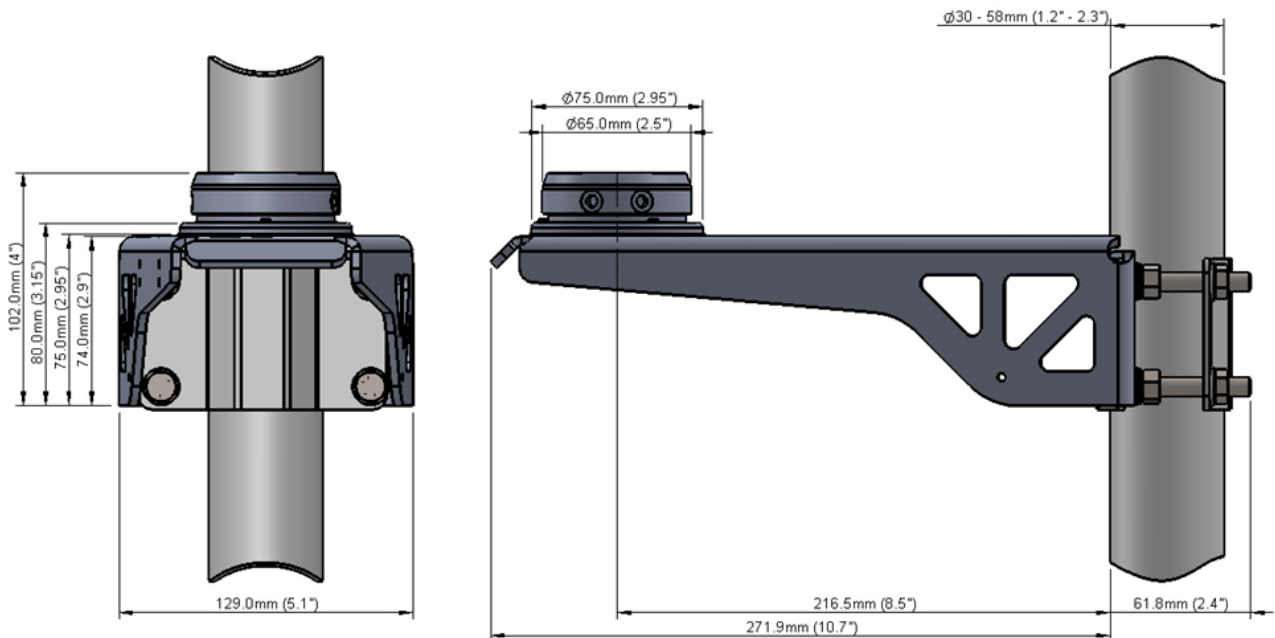

Weight

1.29Kg (without Sensor fitted)

Material

Anodised Aluminium Bracket with Stainless Steel Mount and fittings. An isolation gasket is fitted between the Stainless Steel mount and the Bracket to reduce corrosion.

Ultrasonic Anemometer

Mounting bracket (Short and Long Mounts)

A suggested mounting bracket using Short or Long Mounts is shown in Fig 1. P17

It is recommended that the WindObserver 65 mounting bracket be manufactured from stainless steel 316, to prevent possible galvanic corrosion.

It is also recommended that the supplied gasket be always fitted to ensure IP66 rating and to prevent galvanic corrosion if the mounting bracket is not manufactured from stainless steel 316.

Stainless steel 316 fixings must be used.

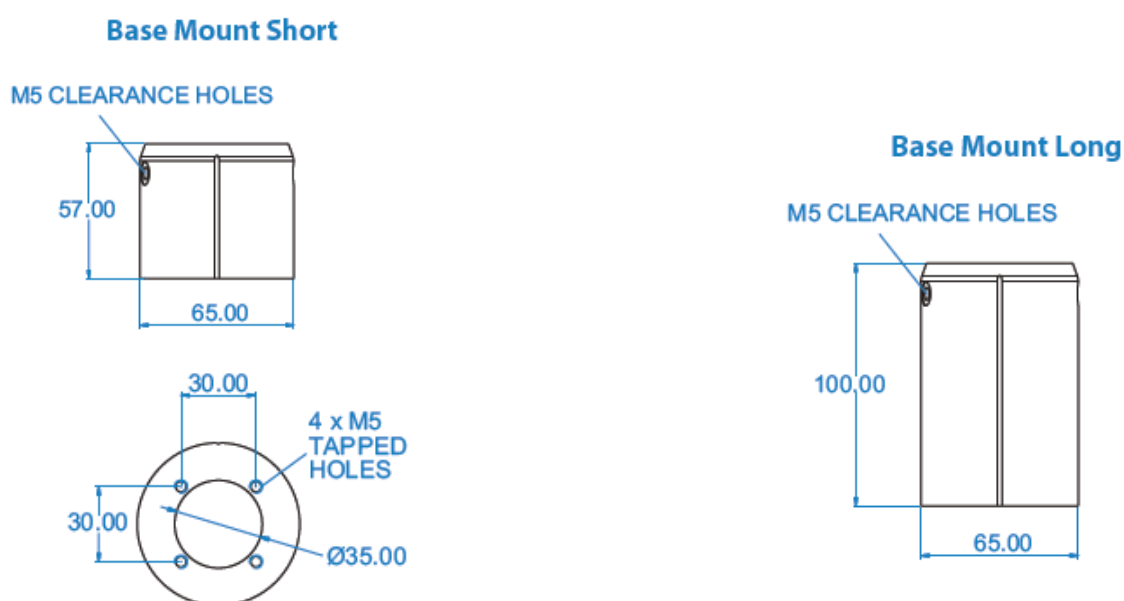

Suggested mounting bracket and Earthing (grounding) arrangements

The example shows a long mount fitted to a cable gland unit, a similar Earthing/ mounting arrangement can be used with short mounts and connector based units.

A mounting kit (1390-10-164) is supplied with the WindObserver 65 to allow assembly of the mount to the base of the WindObserver.

Included in the supplied mounting kit is an O Ring Seal which must be fitted inside of the Base Mount.

Now fit the Base Mount to the WindObserver base using supplied 3 off M5x12 screws, first fit a wavy washer to them, then a flat washer, then the seal washer before screwing to the WindObserver Base mount.

Ultrasonic Anemometer

Figure 1

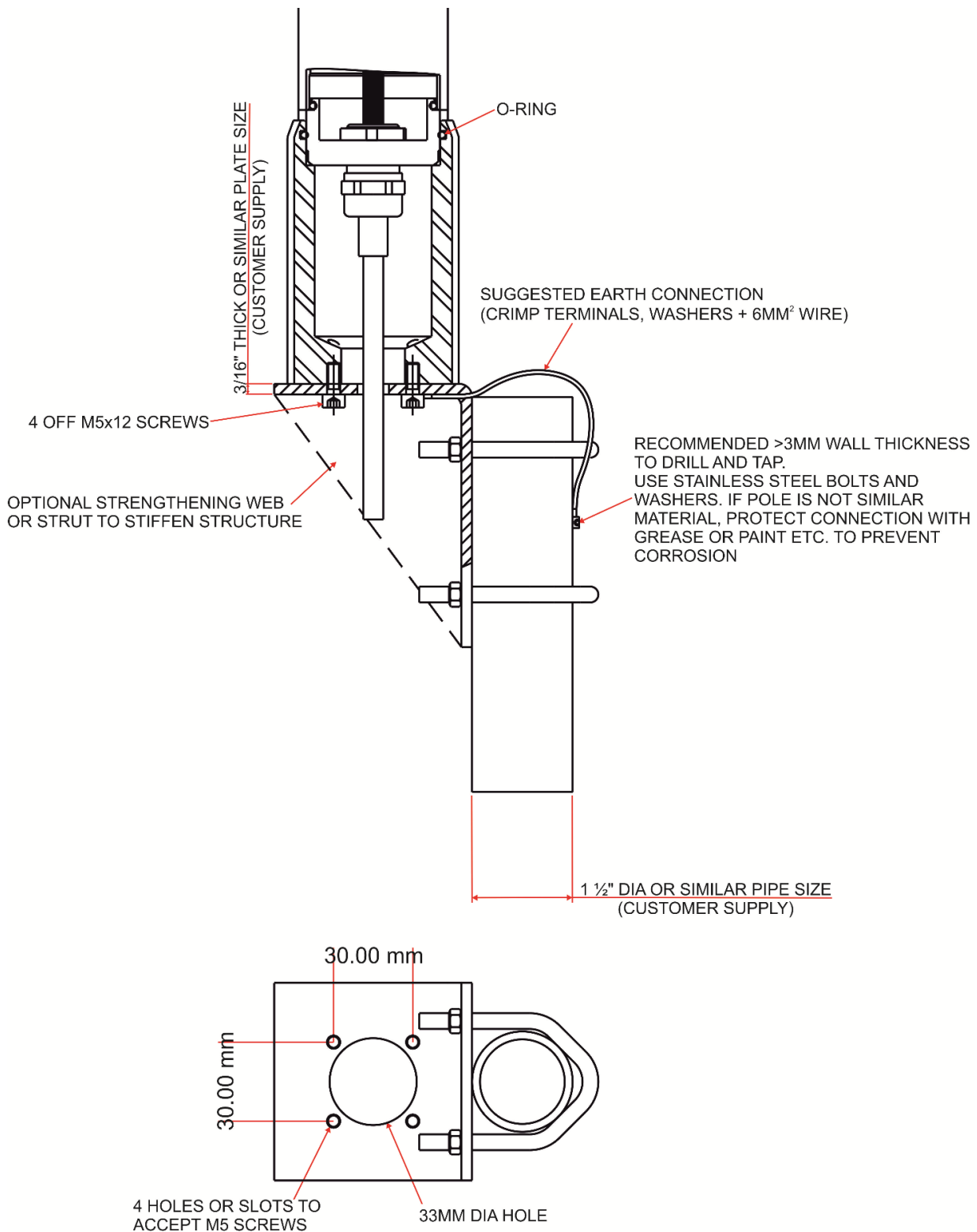

Ultrasonic Anemometer

Pipe mounting (use with Pipe Mount)

The Pipe Mount base for the WindObserver 65 has the following dimensions.

Included in the supplied mounting kit is an O Ring Seal which must be fitted inside of the Pipe Mount Base.

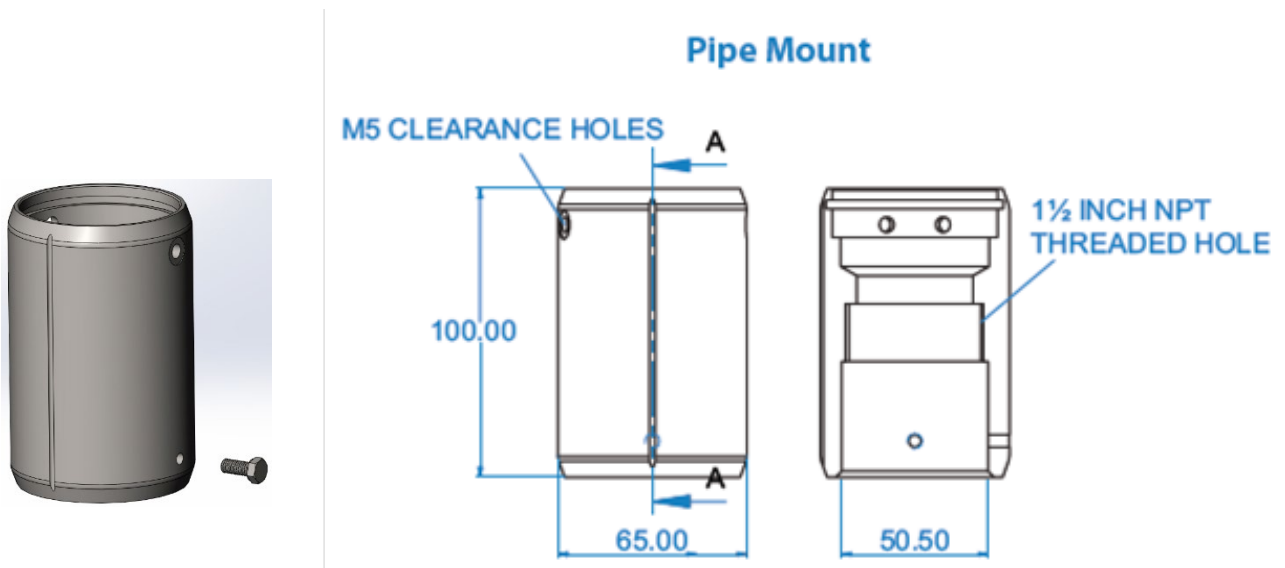

The mounting pole dimension should be 50mm (1.97") diameter.

Three M5 x 12 hex screws are provided to secure the Pipe Mount to the WindObserver base.

Three M5 x 12 hex screws to secure the Pipe Mount to the pipe through M5 tapped holes in the Pipe Mount.

If a screw threaded pole is used it should be a 1.5-inch National Pipe Thread (NPT) type.

It is recommended that the WindObserver mounting pole be manufactured from Stainless Steel 316, to prevent possible galvanic corrosion.

Ultrasonic Anemometer

Custom Mount (Use with WindObserver No Mount Option)

Although it is recommended that customers select a base mount option from Gill Instruments, should a customer wish to design their own mount then the WindObserver base dimension details for this are as follows:-

The WindObserver base has three M5 tapped holes, 8mm deep.

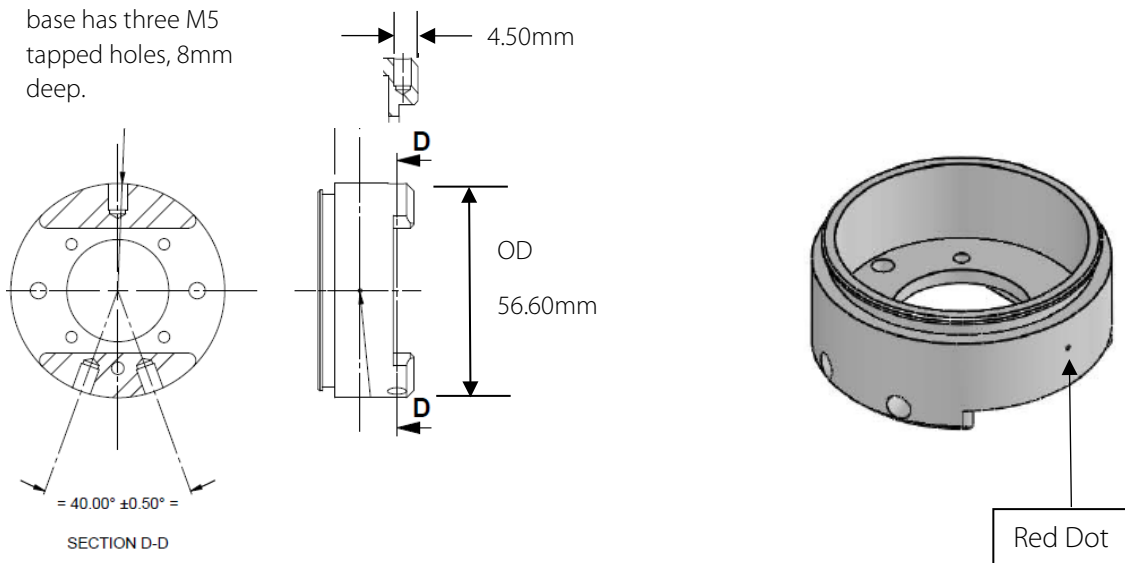

Updated Cable Gland Base Assembly

All models that utilise the cable gland fitment will now have an updated base assembly which will allow for either a direct panel mount attachment (as per the WindObserver 2) or use of the panel/pipe mount adaptors (as per the WindObserver 65/70/75/90):

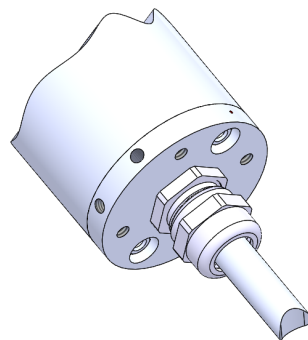

Figure 2; updated base fitment for cable gland model variants

Ultrasonic Anemometer

Alignment

The anemometer should be set to point North (or to another known reference direction), using the North Spar, which can be identified from the red dot on the base of the instrument or vertical groove on short base, long base or pipe mount adaptor.

See page 21, figure 2a.



Since all wind measurements are made relative to the North Spar, it is important to use only the North Spar for alignment and not the red dot located at the base of the unit (only visible without base mount) nor the vertical groove located on the base mount (only when fitted).

If the unit is used in a tunnel, (and the Tunnel format is used), the unit would normally be aligned with the N – S axis in the horizontal plane.

Ultrasonic Anemometer

Figure 2a North Marker (Long Base Mount shown for illustrative purposes)

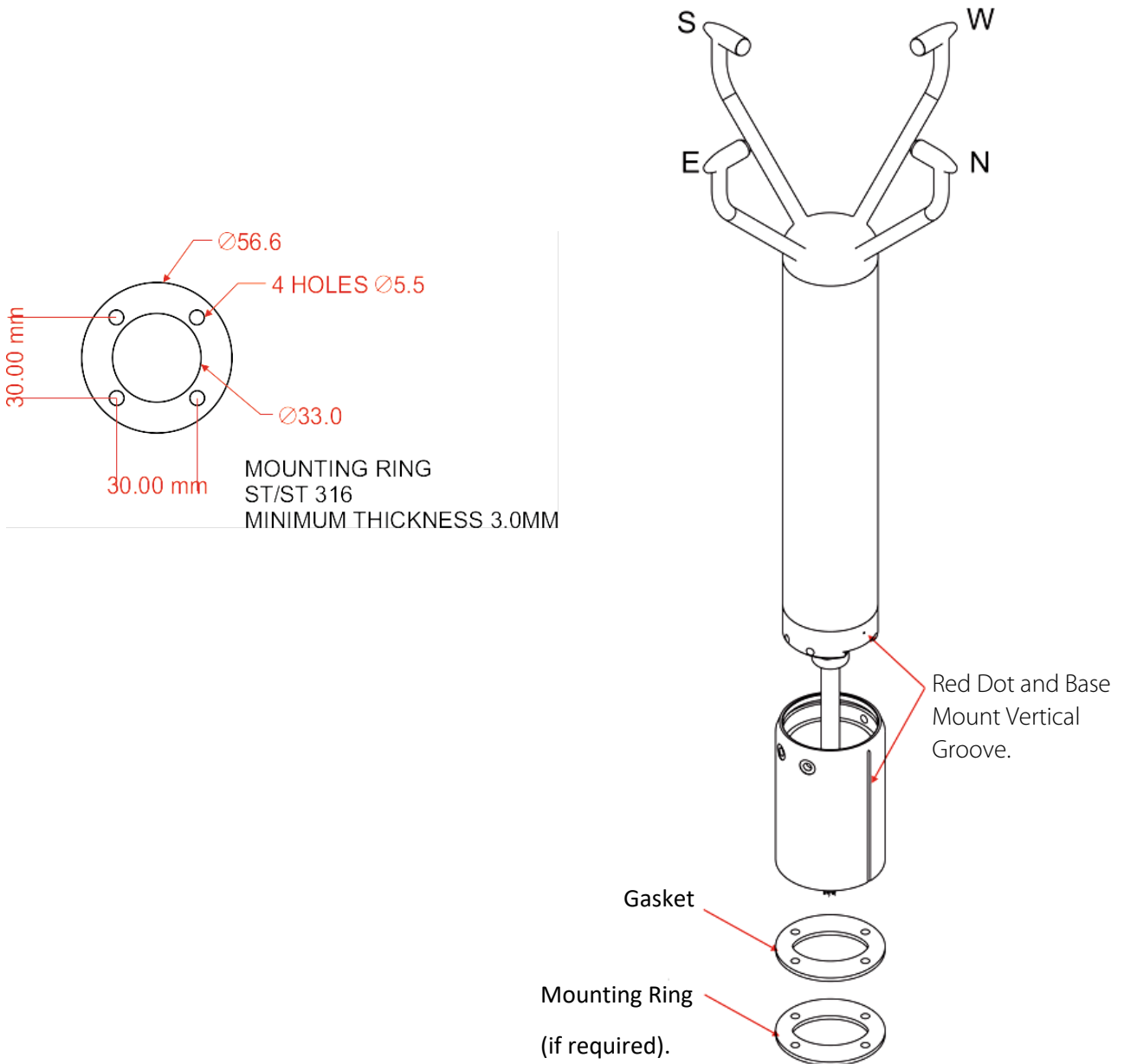

 Pipe Mount units do not require the gasket and mounting ring.

Figure 2b WindObserver 65 outline dimensions

Short Base Mount Unit Dimensions

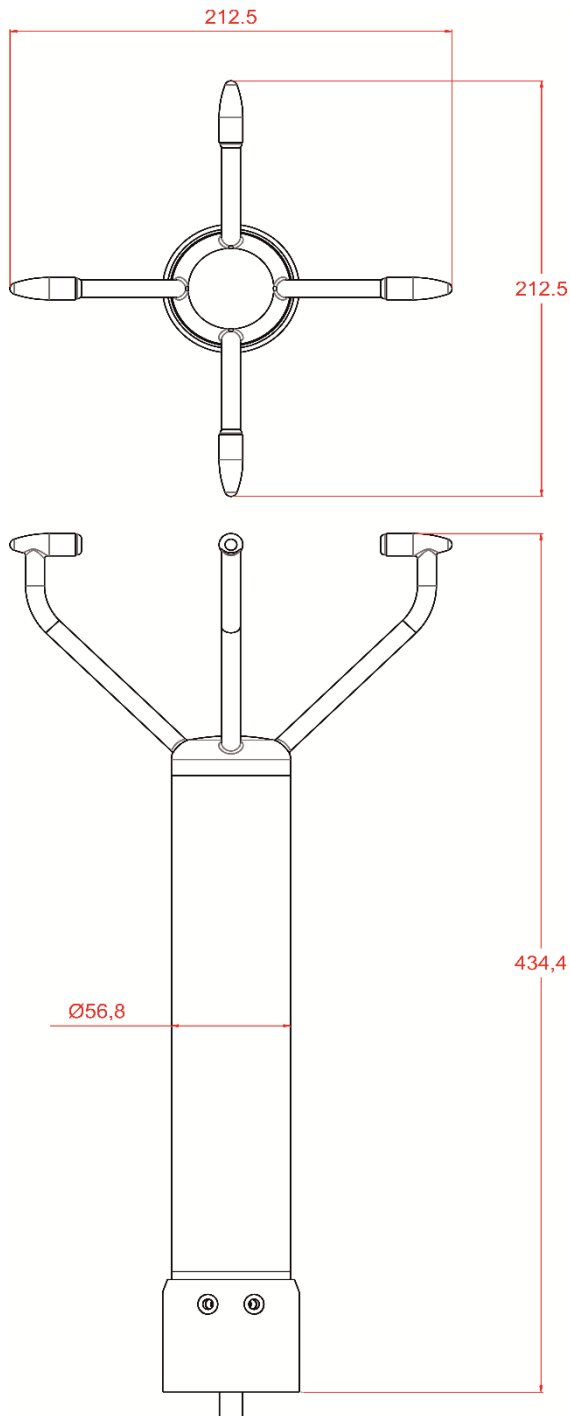

Long Base Mount Unit Dimensions

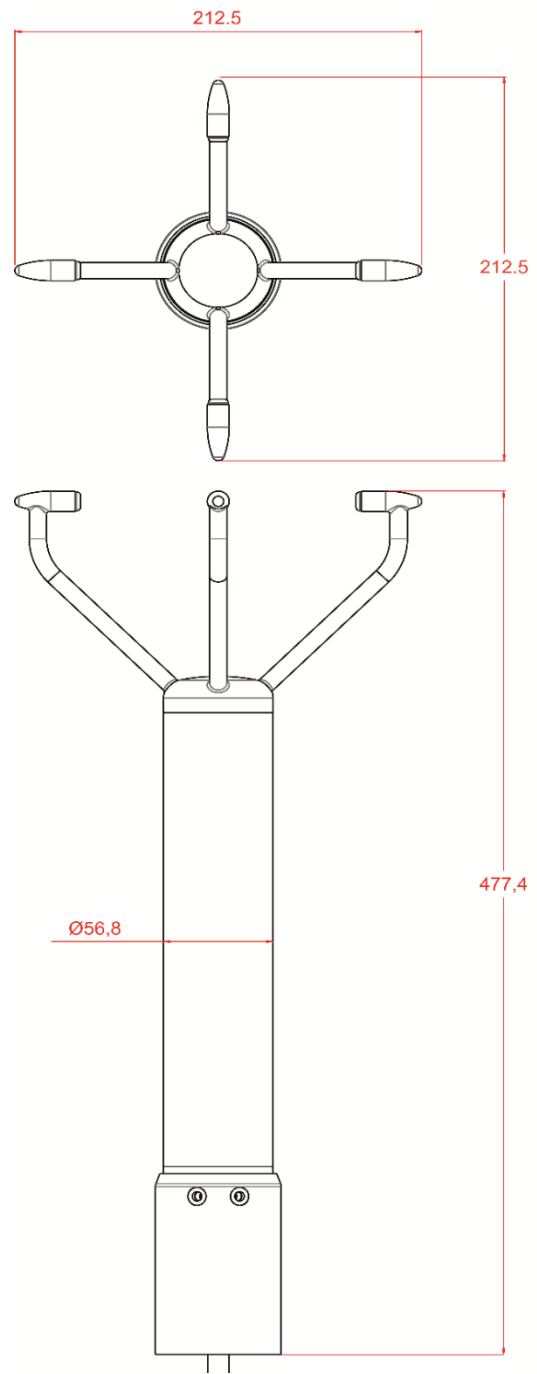

Pipe Mount Unit Dimensions

Ultrasonic Anemometer

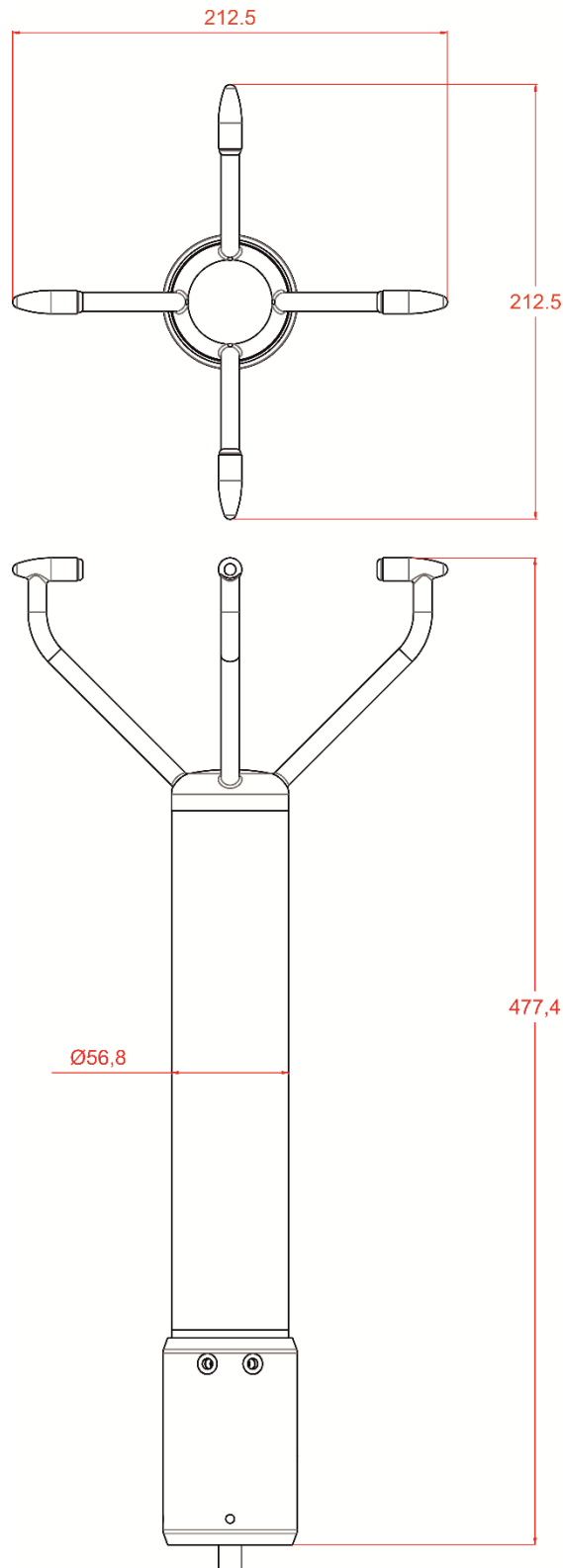

Ultrasonic Anemometer

5. Message Formats & Options

On first applying power to the WindObserver 65, it will be in 'Measurement Mode', and it will output wind measurement information within 3 seconds in one of the formats as described below.

Setting the output format, units, other parameters, options and the communication settings are all carried out in the alternative 'Configuration Mode'.

See Appendix F CONFIGURING for details of how this is done.

The factory default settings are shown here in **bold**, and for convenience some 'Configuration codes' (as used to set the configuration) are shown in blue boxes.

For example M3.

5.1. Wind Speed format

The wind speed measurements can be output in one of the following formats: UV, Polar, Customer formats (NMEA and Tunnel).

5.2. Output format

The UV and Polar wind speed parameters are output in either ASCII or binary. These parameters can be transmitted continuously or polled from the user.

Polar is also available in continuous NMEA format.

Output Formats Table

Output format	Output (see Notes below)	Configuration code
ASCII UV	Continuous	M1
	Polled	M3
ASCII Polar	Continuous	M2
	Polled	M4
ASCII Tunnel	Continuous	M12
ASCII Tunnel	Polled	M13
NMEA	Continuous	M5
Binary Tunnel	Continuous	M6
Binary UV short	Continuous	M7
Binary Polar	Continuous	M8
ASCII Polar	Continuous Averaged	M15
ASCII Polar	Polled Average	M14

Ultrasonic Anemometer



1. Continuous Output: In this mode the unit continuously outputs a burst of RS422 level data (the frequency determined by the output rate setting). After the burst of data and until the next data burst the data lines revert to a high impedance state.
2. Polled Output: In this mode the data lines are in a high impedance state until the unit is polled for data. Upon receipt of a poll command the unit outputs a burst of data at RS485 levels and then reverts to a high impedance state until the next poll command receipt.

Low wind speeds

Whilst the wind speed is below 0.05 metres/sec, the wind direction will not be calculated, and the last known good direction figure is shown. All other output parameters will continue to update at the output rate

5.3.Units

The wind speed can be set to any of the following units:

Unit	Abbreviation
Metres per sec	m/s
Knots	knots
Miles per hour	MPH
Kilometres per hour	kph
Feet per minute	fpm

5.4.Output rate

The output frequency can be set between 1 and 10 per second. The wind speed is sampled every 25ms, each axis being sampled sequentially. The following Table lists the possible outputs per second and the corresponding number of averaged samples. A 25ms sample period is used to process and output the results.

Outputs per Second	Sample Average
1	39
2	19
4	9
5	7
8	4
10	3

Ultrasonic Anemometer

5.5. Averaging (Digital Data)

There are two digital averaging options: -

5.5.1. G Command Averaging

Using the G Command in association with modes other than M14, M15 and polled modes.

The Averaging Period can be set from zero to 3600 secs. (1 hour). The default setting is zero. When averaging is enabled, data is output at a rate determined by the averaging period. The data is an average of valid data collected during the averaging period.

If G is set to zero, then averaging settings will be disabled.

For instance, if the unit is set for G0025 then every 25 seconds there will be a single result output that provides the average of the wind direction and magnitude data over the last 25 seconds.

A,219,000.78,M,60,0D

A,202,000.79,M,60,06

A,207,001.22,M,60,0C

A,220,000.48,M,60,04

5.5.2. Road Weather Averaging (RWA)

Modes 14 and 15

The averaging is implemented with reference to the following standard:

- Guide to Meteorological Instruments and Methods of Observation – World Meteorological Organization WMO-No8 seventh edition 2008 ISBN 978-92-63-10008-5

The direction and magnitude outputs are derived from the vector sum of U and V over the RWALONG averaging period (default 10 minutes in P1).

The gust output is derived from the vector sum of U and V over 3 readings (3 seconds in P1), and the max gust is the maximum of the gust value over the RWASHORT period (default 60 seconds in P1). The max gust value is reset to zero at the end of each RWASHORT period.

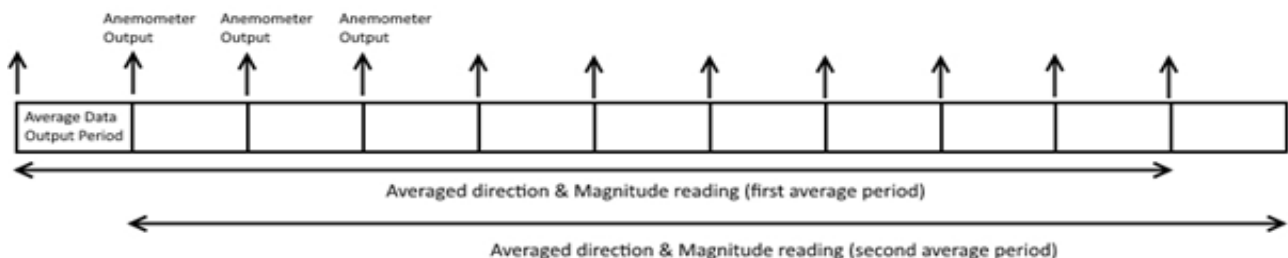

Ultrasonic Anemometer

RWA Default settings are: -

P (Output rate Hz) = 1
RWASHORT = 60
RWALONG = 10

Therefore:

Anemometer output period = $60/1 = 60$ seconds (the WindObserver will output a reading every 60 seconds).

Averaged direction and magnitude reading = $10 \times 60 = 600$ seconds

(This is the time the readings will be averaged over).

When the average building period has been completed, the average reported thereafter will be a rolling average derived from the last averaged direction and magnitude time period.

Mode 15 – Averaging Data in Continuous mode.

Averaged Digital Data Output comprises of.

<Start of String> , Unit Identifier, Mode, Averaged Direction, Averaged Magnitude, units, Maximum Gust Direction, Maximum Gust Magnitude, Status, , checksum.

e.g.

0A,M15,293,000.03,M,338,000.05,51,▼47

(status code 51 shows measurement average building, non-heat enabled units only).

0A,M15,198,000.04,M,088,000.39,00,▼4B

(status code 00 code shows measurement average building period complete and normal operation, non-heat enabled units only).

Principle set up commands associated with this averaging mode are: -

Px:- Measurement Rate, (P1) this command sets the underlying measurement rate 1Hz.

RWASHORT xx: - Short Term Number, where xx is a number from 10 to 60.

RWALONG xx: - Long Term Number, where xx is a number from 1 to 10.

Therefore, with the RWASHORT number set for 60 (default) and P command set for 1Hz (P1 default) the unit will output a rolling averaged reading every 60 seconds.

The Averaged Data Output period in seconds is: -

RWASHORT Number

Measurement Rate (P Setting Hz value)

Therefore, with the RWASHORT number set for 60 (default) and P command set for 1Hz (P1 default) the unit will output a rolling averaged reading every 60 seconds.

The Averaged Direction and Magnitude reading is based on: - RWALONG Number * Averaged Data Output period.

Ultrasonic Anemometer

```
0A,M15,293,000.03,M,338,000.05,51,47
0A,M15,301,000.03,M,304,000.04,51,43
0A,M15,299,000.03,M,285,000.02,51,40
0A,M15,303,000.02,M,336,000.02,51,47
0A,M15,291,000.03,M,200,000.64,51,48
0A,M15,291,000.02,M,301,000.03,51,48
0A,M15,243,000.04,M,172,001.52,51,42
0A,M15,236,000.03,M,090,000.08,51,44
0A,M15,243,000.03,M,099,000.09,51,4E
0A,M15,198,000.04,M,088,000.39,00,4B
0A,M15,180,000.04,M,099,000.09,00,41
0A,M15,180,000.03,M,345,000.03,00,4E
```

The Maximum Gust Direction is the direction of the maximum gust measured over the short term output period. Gust is generated from a rolling 3s average of the short term output period, and reset at the end of short term output period.

The maximum Gust Magnitude is the magnitude of the maximum gust measured over the short term output period. Gust is generated from a rolling 3s average of the short-term output period and reset at the end of short-term output period.

Notes: -

Non Heat Enabled Units - Whenever the unit is powered up then until the unit has reached its minimum long term averaging interval the status code will read 51 (Measurement Average Building).

Heat Enabled Units - On units where heat is enabled Code 51 will not be output during the measurement average building period, therefore allow for this period on power up before taking readings to be fully averaged (maximum period of 10 minutes).

The G Command setting has no effect on Mode 14 and Mode 15 Settings.

Mode 14 – Averaging Polled Mode

See Mode 15 for data output format and command explanations.

For ease of use before changing to this Mode set all other WindObserver parameters first including: -

Px:- Measurement Rate, (P1) this command sets the underlying measurement rate of 1Hz.

RWASHORT xx: - Short Term Number, where xx is a number from 10 to 60.

RWALONG xx: - Long Term Number, where xx is a number from 1 to 10.

Once set for Mode 14, to Poll for averaged data use the ? command followed by the unit designator A (default setting, ensure capitol letter used).

Ultrasonic Anemometer

The polled mode commands available in this mode are:

Description	Command	WindObserver response
Enable Polled Mode	?	(None)
WindObserver Unit Identifier (N)	A.....Z	Output generated
Disable Polled mode	!	(None)
Request WindObserver Unit Identifier	&	A Z (as configured)
Enter Configuration mode	*<N>	CONFIGURATION MODE

Where <N> is the unit identifier, if used in a multi-drop system then it is recommended that ID's A to F and KMNP are not used as these characters can be present in the data string.

It is suggested that in polled mode the following sequence is used for every poll for information.

? Ensures that the Sensor is enabled to cover the event that a power down has occurred.

A-Z Appropriate unit designator (capitol letter) sent to retrieve a line of data.

! Sent to disable poll mode and reduce possibility of erroneous poll generation.

When polled with the default Mode 14 factory setting the WindObserver (set for default 1Hz output) will output the last valid 10-minute wind speed and direction average, updated every minute along with last valid 1 minute Gust magnitude.



Non Heat Enabled Units.

If the unit is powered up and polled before the unit has reached its minimum averaging interval the status code will read 51 (Measurement Average Building, non-heat enabled units only).

Heat Enabled Units.

On units where heat is enabled Code 51 will not be output if polled during the measurement average building period, therefore allow for this period on power up before taking readings to be fully averaged (maximum period of 10 minutes).

Ultrasonic Anemometer

```
0A,M15,293,000.03,M,338,000.05,51,♥47
0A,M15,301,000.03,M,304,000.04,51,♥43
0A,M15,299,000.03,M,285,000.02,51,♥4D
0A,M15,303,000.02,M,336,000.02,51,♥47
0A,M15,291,000.03,M,200,000.64,51,♥48
0A,M15,291,000.02,M,301,000.03,51,♥48
0A,M15,243,000.04,M,172,001.52,51,♥42
0A,M15,236,000.03,M,090,000.08,51,♥44
0A,M15,243,000.03,M,099,000.09,51,♥4E
0A,M15,198,000.04,M,088,000.39,00,♥4B
0A,M15,180,000.04,M,099,000.09,00,♥41
0A,M15,180,000.03,M,345,000.03,00,♥4E
```

5.6.Options

Heating (If fitted)

Heating is autonomous and requires no set-up once activated.

45° Offset

If required, the U axis can be offset +45° to the transducer axis.

Vertical Output Padding

A dummy W vector is inserted to provide compatibility with any WindMaster that may be in a network.

Ultrasonic Anemometer

5.7.ASCII message format (UV, Polar and Tunnel)

ASCII UV format

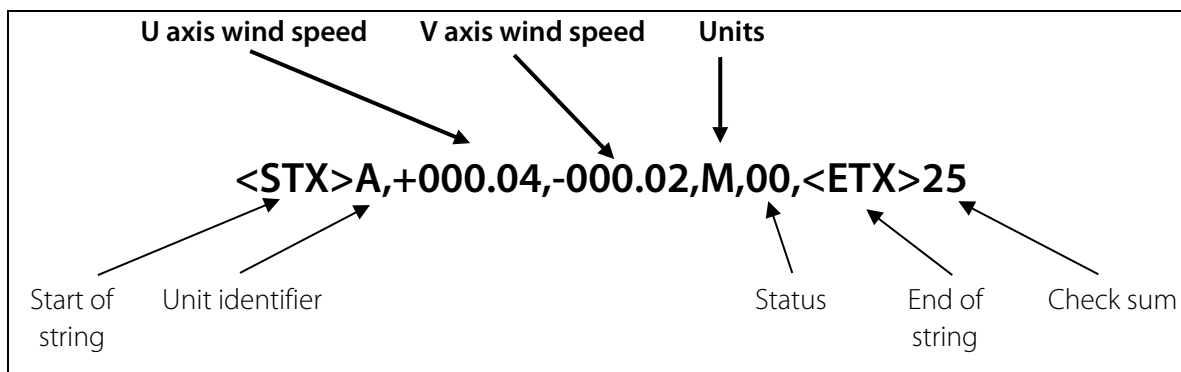

Where

U axis wind speed In increments of 0.01 units (\pm UUU.UU)
V axis wind speed In increments of 0.01 units (\pm VV.V)

Units	Value	Units
	M	Metres per second (m/s)
	N	Knots (knots)
	P	Miles per hour (MPH)
	K	Kilometres per hour (kph)
	F	Feet per minute (fpm)

Start of string ASCII value 2

Unit identifier Letter A – Z (**default A**)

Status	Value	Status
	0	OK
	60	Heating enabled and OK if enabled
	Any other value	Warning or fault condition - see Appendix K

End of string ASCII value 3

Check sum Exclusive OR of all characters between Start of String and End of String reported as ASCII hex.

Ultrasonic Anemometer

ASCII Polar format

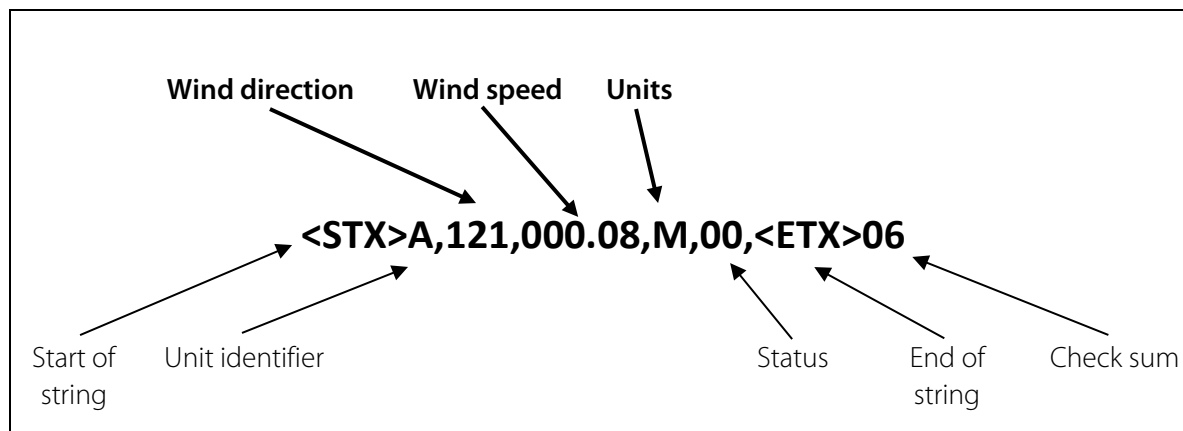

Where

Wind direction	In degrees relative to N (DDD)
Wind speed	In increments of 0.01 units (±MMM.MM)
All other parameters	See Section 5.7 ASCII UV format

ASCII Polled (UV and Polar)

When in the Polled mode, an output is only generated when the host system sends a Poll signal to the WindObserver consisting of the WindObserver Unit Identifier – that is, the relevant letter A – Z.

The output formats are otherwise as described above.

The commands available in this mode are:

Description	Command	WindObserver response
WindObserver Unit Identifier	A Z	Wind speed output generated
Enable Polled mode	?	(None)
Disable Polled mode	!	(None)
Request WindObserver Unit Identifier	&	A Z (as configured)
Enter Configuration mode	*<N>	CONFIGURATION MODE

Where <N> is the unit identifier, if used in a multi-drop system then it is recommended that ID's A to F and KMNP are not used as these characters can be present in the data string.

Ultrasonic Anemometer

It is suggested that in polled mode the following sequence is used for every poll for information.

- ? Ensures that the Sensor is enabled to cover the event that a power down has occurred.
- A-Z Appropriate unit designator sent to retrieve a line of data.
- ! Sent to disable poll mode and reduce possibility of erroneous poll generation.

When in polled mode the system will respond to the data command within 30mS with the last valid data sample as calculated by the Output rate (P Mode Setting).

If the unit is powered down after use or upon switch on then allow 3 seconds from switch on before sending poll commands.

ASCII format – Tunnel Mode

In this mode, the output is given as signed (i.e. positive or negative) speeds along the 'U' (= South – North) axis and direction as a 1 or 0.

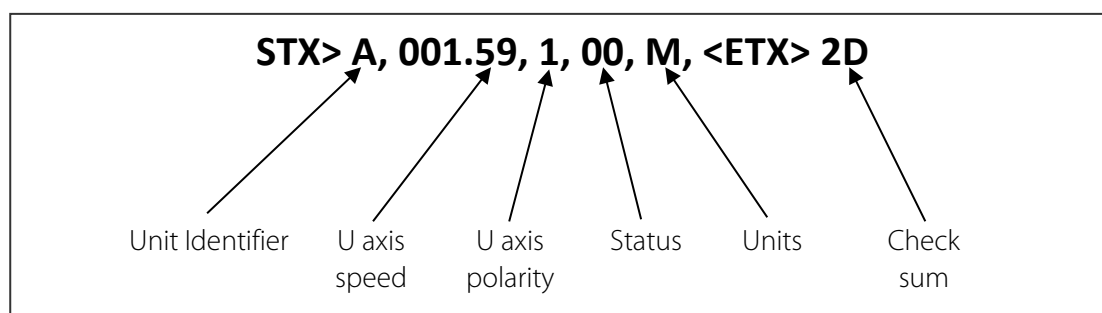

Where:

- <STX> = Start of string character (ASCII value 2)
- Unit Identifier = Letter A to Z (A Default)
- U axis = U axis Wind Speed
- U axis = U axis Wind Direction Polarity
where 0 (-U vector) is a wind from the North
direction or 1 (+U vector) is a wind from the South direction.

All other parameters *See Section 5.7 ASCII UV format*

Ultrasonic Anemometer

5.8.Binary message format (UV, Polar and Tunnel)

Binary UV format

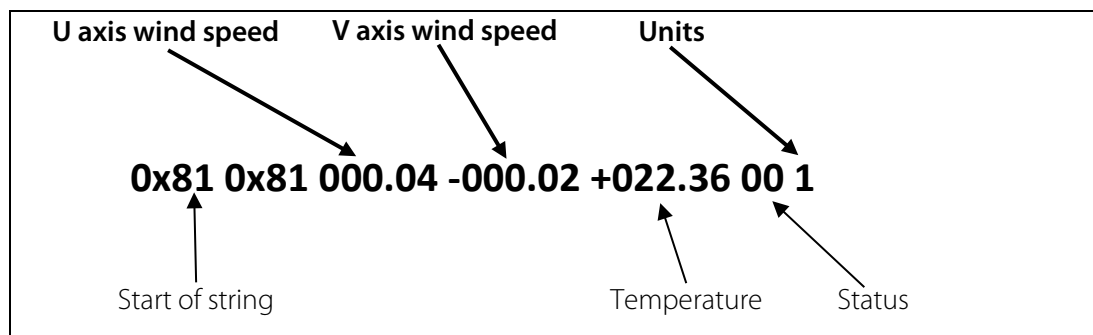

Where

U axis wind speed

In increments of 0.01 units ($\pm UUU.UU$)

V axis wind speed

In increments of 0.01 units ($\pm VVV.VV$)

Units

Value	Units
1	Metres per second (m/s)
2	Knots (knots)
3	Miles per hour (MPH)
4	Kilometres per hour (kph)
5	Feet per minute (fpm)

Start of string

Speed of sound

In metres per second (if enabled)

Temperature

Sonic temperature in degrees C (two's complement signed) (if enabled)

Status

Value	Status
0	OK
60	Heating enabled and OK
Any other value	Warning or fault condition - see Section Appendix K

Ultrasonic Anemometer

Binary Polar format

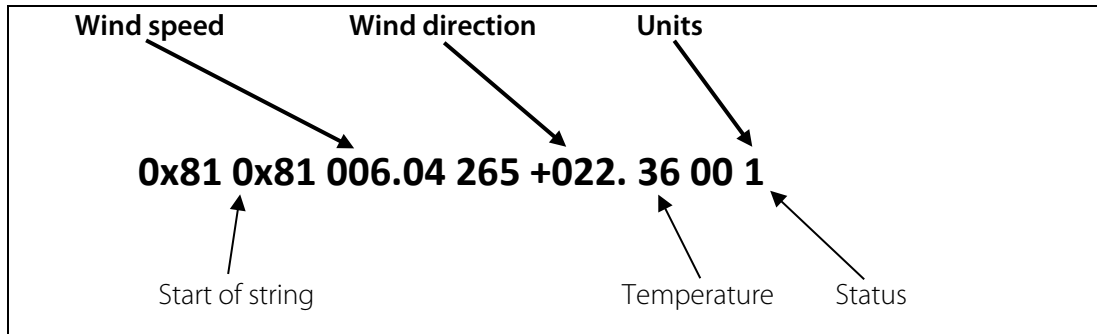

Where

Wind direction	In degrees relative to N (DDD)
Wind speed	In increments of 0.01 units (±MMM.MM)
All other parameters	See Section 5.8 Binary UV format

Binary Tunnel format

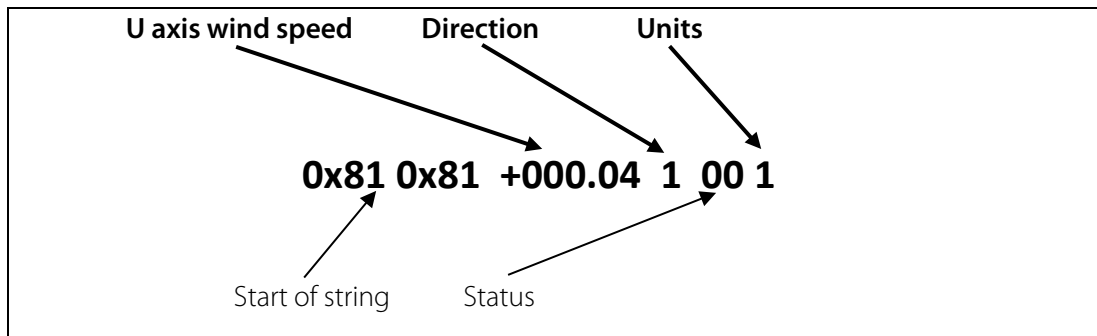

U axis Wind speed	In increments of 0.01 units (±MMM.MM)	
Direction (along U axis)	Value	Polarity
	1	+U
	0	-U
Other parameters	See Section 5.8 Binary UV format	

Ultrasonic Anemometer

5.9.NMEA Format

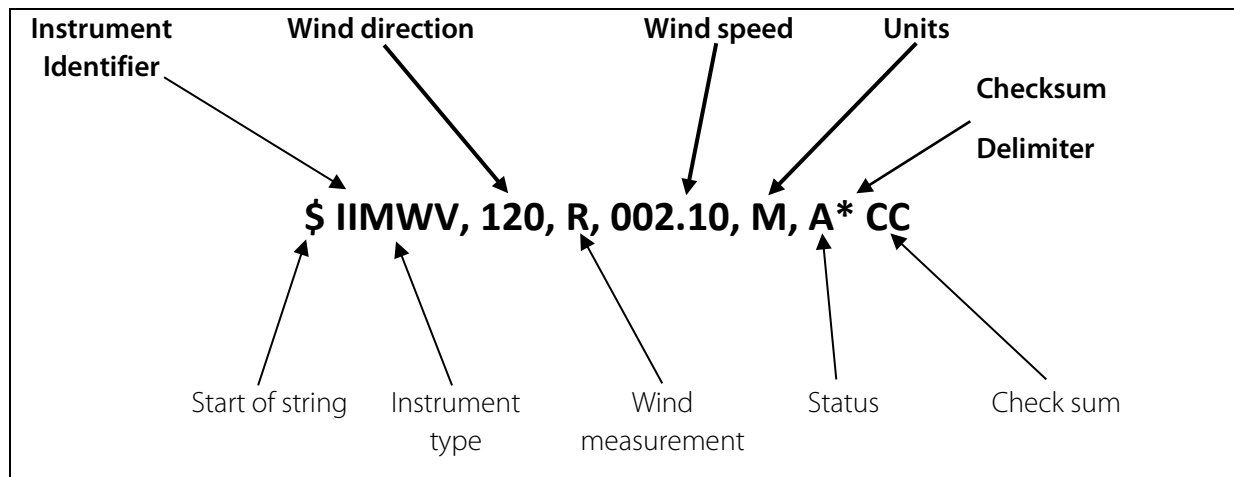

Where

Wind direction		In degrees relative to North (DDD)
Wind speed		In increments of 0.01 units (±MMM.MM)
Units	M	Metres per second (m/s)
	N	Knots (knots)
	P	Miles per hour (MPH)
	K	Kilometres per hour (kph)
	F	Feet per minute (fpm)
Start of string	\$	
Instrument type	IIMWV	
Wind measurement	R	Relative wind measurement
Status	A	A cceptable measurement
	V	V oid measurement
Check sum		Exclusive OR of all characters between '\$' and '*' reported as ASCII hex.

A typical WindObserver 65 configuration suitable for NMEA would be:

B2, E1, F1, G0, K1, L1, M5, O1, P1, U1.

Consult specification NMEA 0183 version 3 (available on the web) www.nmea.org for complete interface details.

Ultrasonic Anemometer

5.10. Averaging Format (Modes 14 and 15)

See also Para 5.5.2.

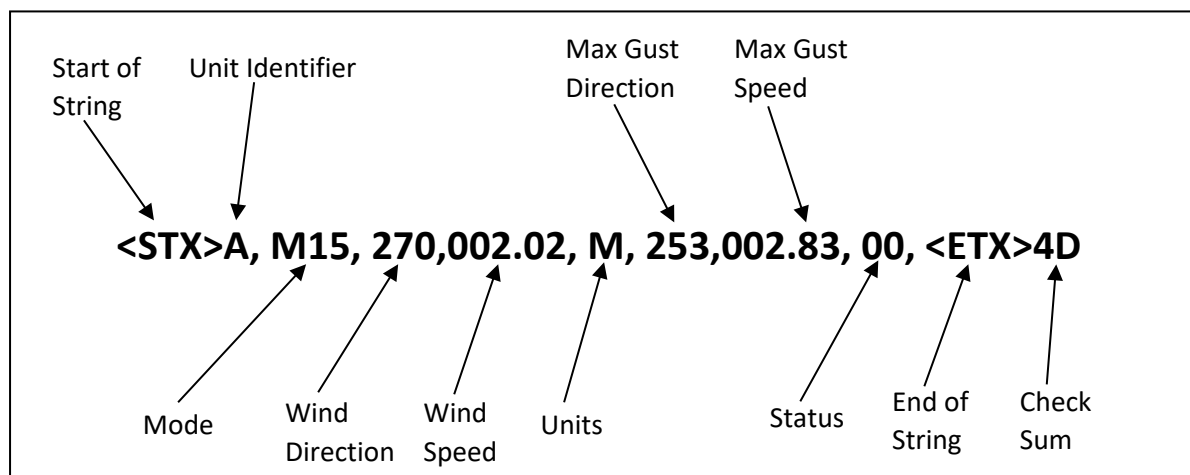

Start of string	ASCII value 2	
Unit identifier	Letter A – Z (default A)	
Mode	M14	Polled Averaging
	M15	Continuous Output Averaging
Wind Direction	In degrees relative to North (DDD) settable average of direction in degrees.	
Wind Speed	In increments of 0.01 units (\pm MMM.MM), settable average of speed in m/s.	
Units	M	Metres per Second
	N	Knots
	P	Miles per Hour
	K	Kilometres per Hour
	F	Feet per Minute
Max Direction Gust	In degrees relative to North (DDD)	
Max Gust Speed	In increments of 0.01 units (\pm MMM.MM)	
Status	Value	Status
	00	OK
	60	Heating enabled and OK if enabled
	51	Means that the averaging is incomplete (non- heat enabled units only).
	Any other value	Warning or fault condition - see Section Appendix K
End of string	ASCII value 3	
Check sum	Exclusive OR of all characters between Start of String and End of String reported as ASCII hex.	

Ultrasonic Anemometer

Appendix A - Technical Specification

Wind Measurement	
Parameters	UV, Polar, NMEA, Tunnel
Output	1,2,4,5,8,10Hz
Averaging	Flexible 1-3600 seconds or Adjustable Averaging for Road Weather applications
Wind Speed	
* Values are dependent on anemometer being used	
Range	0 - 65m/s (0-145mph)
Accuracy	±2%@12m/s
Resolution	0.01m/s
Offset	±0.01m/s
Units of Measurement	m/s, Knots, MPH, KPH ft/min
Wind Direction	
Range	0-359 Degrees
Accuracy	± 2°
Resolution	1°
Anemometer Status	Supplied as part of standard message
Starting Threshold	0.01 m/s
Dead Band Wind Direction	None
Power Requirement	
Input Voltage	9-30V DC 30mA @ 12V DC
Reverse voltage protected	YES
Heating - Optional	Allow 3A @ 22v to 30v (max) AC rms or DC
Digital Output	
Communication	RS422, full duplex, RS485 2 wire network facility
Baud rates	1200, 2400, 4800, 9600, 19200, 38400
Formats	8 data bits, odd, even or no parity, 1 stop bit
Weight & Dimensions	
Size	See manual Fig 2b for dimensions
WindObserver 65 Weight	1.34kg (no mount or lead)
Base Mount Short	0.63kg
Base Mount Long	1.05kg
Pipe Mount	1.06kg
Materials	
External Construction	Stainless Steel 316

Ultrasonic Anemometer

Environmental	
Moisture protection	IP66 (NEMA4X)
Operating temperature	-55°C to +70°C (heated version)
Humidity	0% to 100% RH
Precipitation	300mm/hr
Humidity	0 to 100%
EMC	EN 61326-1:2006 EN 60945:2002 FCC CFR47 Parts 15.109 Class A
Icing	MILSTD810F Method 521.1 Procedure 1

Standards
Traceable to UK national standards Lloyds Register Type Approved

Site Calibration
None required. (See Appendix L Maintenance & Fault-Finding)

Ultrasonic Anemometer

Appendix B - Connector and Cable Assembly

The WindObserver 65 variant with a connector base is supplied with a mating 19-way connector.

Open the pack of connector parts supplied (**Gill Part 1390-10-163**).

A set of assembly instructions are supplied with the connector together with:-

Table of Equivalent Part Numbers		
Part Name	Gill Part No.	Cannon Trident Part No.
Connector head, 19 way	020-04464	192993-0054
Metal backshell (7 pieces)	020-04465	192993-0084
Solder bucket contacts (5 per pack, (4 –off packs))	020-04469	192900-0635

Arrange Backshell (Gill Part Number 020-04465)

Pass parts 1-6 along the cable as per the diagram below.

(Note that the connector supplies the correct strain relief for cables with an outside diameter of 7.9 to 12.6mm).

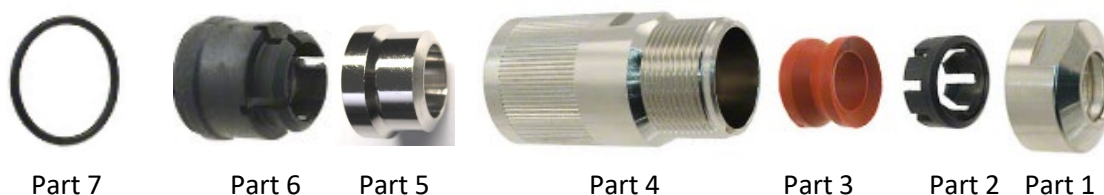

Prepare Cable (e.g., Gill Part 026-02663).

Trim back the cable outer and twisted pair screen sleeves 40mm (see diagram below).

Trim back the screen drain wires to a length of 24mm.

Strip back the connection wires by 7.1mm and tin solder.

Solder the wires to the bucket contacts (will take 14awg to 26awg wire).

Unused wires should be cut back and insulated.

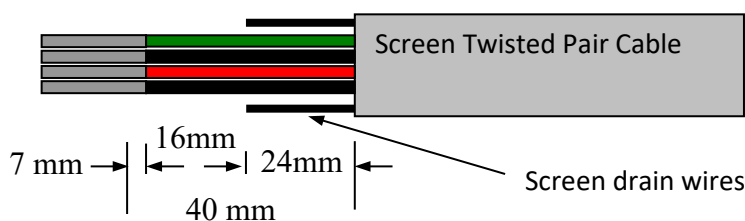

Ultrasonic Anemometer

Prepare Connector Head (Gill Part 020-04464).

Remove the connector thread protector and place the O-ring (part 7) into the groove of the connector head (020-04464).

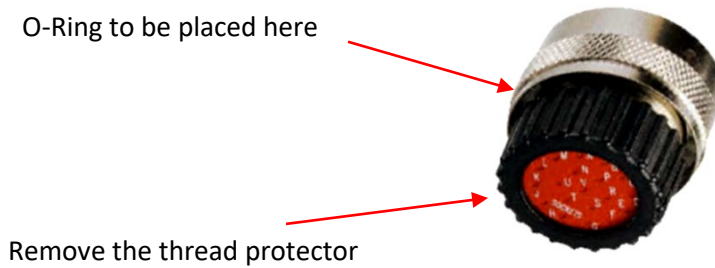

Assemble Connector to the Cable

Referring to Page 40 and Page 43 push connector contacts through the red connector head seal into the appropriate location, when in place there should be a click as the contact locks into position.

Once contacts are in position pass part 6 up the cable and into position as shown below.

Note: if a connector pin needs removing use Cannon Extraction Tool, Manufacturer's Part 192922-1450.

1. Fold and spread screen wires over part 6 and then push up part 5 as shown to clamp screen wires between Parts 5 and 6.
- 2.

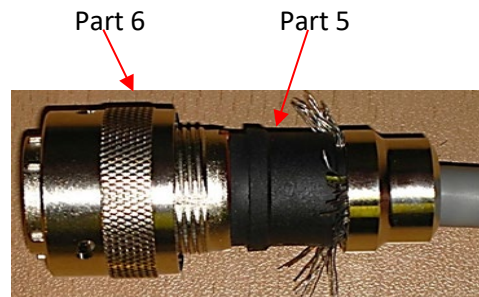
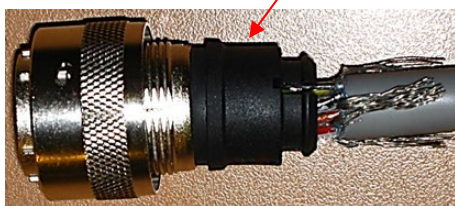

3. Now screw in part 4 and torque up to a value of 10Nm.

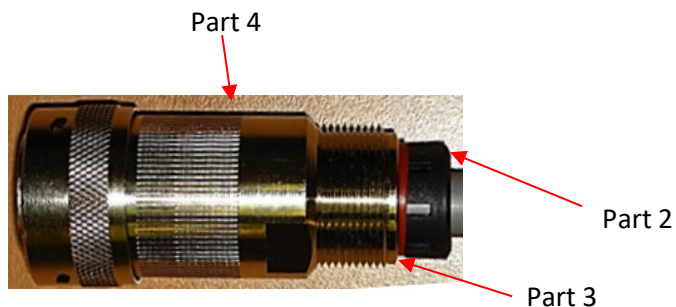

Ultrasonic Anemometer

4. Pass parts 3 and 2, the cable seal and cable grip from the connector kit, along the cable to the housing.
5. Now screw in item 1, the clamp nut, over parts 2 and 3 and onto the housing and torque up to a value of 10Nm.



Part 1

Ultrasonic Anemometer

Appendix C - Connections and default setup



Connections

Important any cable wires not used should be isolated and grounded at the terminating equipment/user end.

Do NOT connect the unit's 0V, heating -ve, or digital 0V to the screen or earth.

On units with integral cable the screens of each pair are joined together inside the anemometer - these should be joined to the cable screen(s) of any further cable run. Avoid long grounding loops. Digital 0V should be used in conjunction with RS422 TX RX lines in order to improve noise immunity.

Earthing or grounding

To ensure correct operation, and for maximum protection against lightning, the anemometer **MUST** be correctly earthed (grounded) via its mountings. Inadequate Earthing will degrade anemometer performance, particularly in the presence of radio frequency interference.

See page 17, Fig 1 Suggested mounting bracket and Earthing (grounding) arrangements

The unit **MUST** be connected to an appropriate grounding point with a minimum of 6mm² copper wire, via the M5 base screws. The cable screens must be joined with any cable screen continuing from the unit's cable via a junction box. The primary earth for the anemometer must be provided via the base screws and not via the cable screens.

View of the WindObserver 65 base connector variant

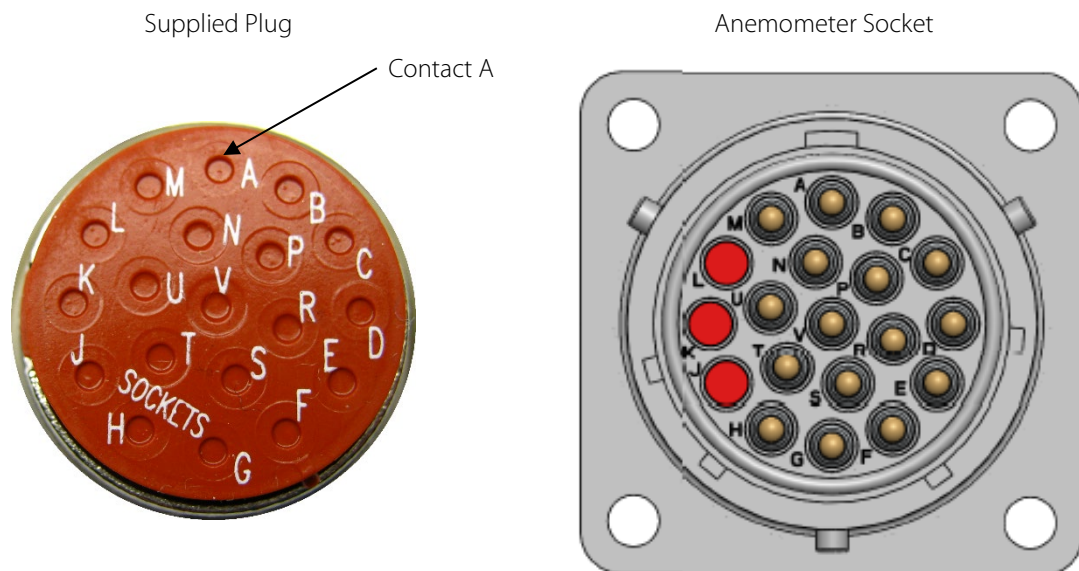

Ultrasonic Anemometer

Table 2 - 19-way connector and cable connections

19 Way Connector Terminal Letter	Cable Gland Option		Signal Designation
	Conductor	Colour	
P	Pair 1	Green	RS422 TXB (+)
C	Pair 1	Black	RS422 TXA (-)
U	Pair 2	White	RS422 RXB (+)
V	Pair 2	Black	RS422 (RXA (-)
R	Pair 3	Red	Supply V+
D	Pair 3	Black	Supply V -
M	Pair 4	Blue	Digital 0v
N	Pair 4	Black	Not Used (Isolate)
A	Pair 5	Yellow	Heater + *
B	Pair 5	Black	Heater -*
E	Pair 7	Orange	Not Used (Isolate)
F	Pair 7	Black	Not Used (Isolate)
L No Connection	Pair 9	Green	Not Used (Isolate)
K No Connection	Pair 9	Red	Not Used (Isolate)
J No Connection	Not Applicable	Not Applicable	Not Used



* may not be functional - check model number and options fitted.

Ultrasonic Anemometer

WindObserver 65 Default Set-up

Default Settings

The factory default settings are:

Non - heated units

A0 B3 C1 E1 F1 G0000 J1 K1 L1 M2 NA O1 P1 T1 U1 V1 X1 Y1 Z1 DR0

Plus RWASHORT 10 and RWALONG 60.

Heated units

A0 B3 C1 E1 F1 G0000 H2 J1 K1 L1 M2 NA O1 P1 T1 U1 V1 X1 Y1 Z1 DR0

Plus RWASHORT 10 and RWALONG 60.



That Heating (H command) is enabled as a default condition. If heating is not required enabled then the H command must be set for H1.

See Section Appendix F Configuring for further details

Ultrasonic Anemometer

Connecting to a PC with a RS422 or RS485 input

The PC requires either an internal RS422 interface card, or an external RS422/485 to RS232 or USB converter, which will plug into the PC or host equipment.

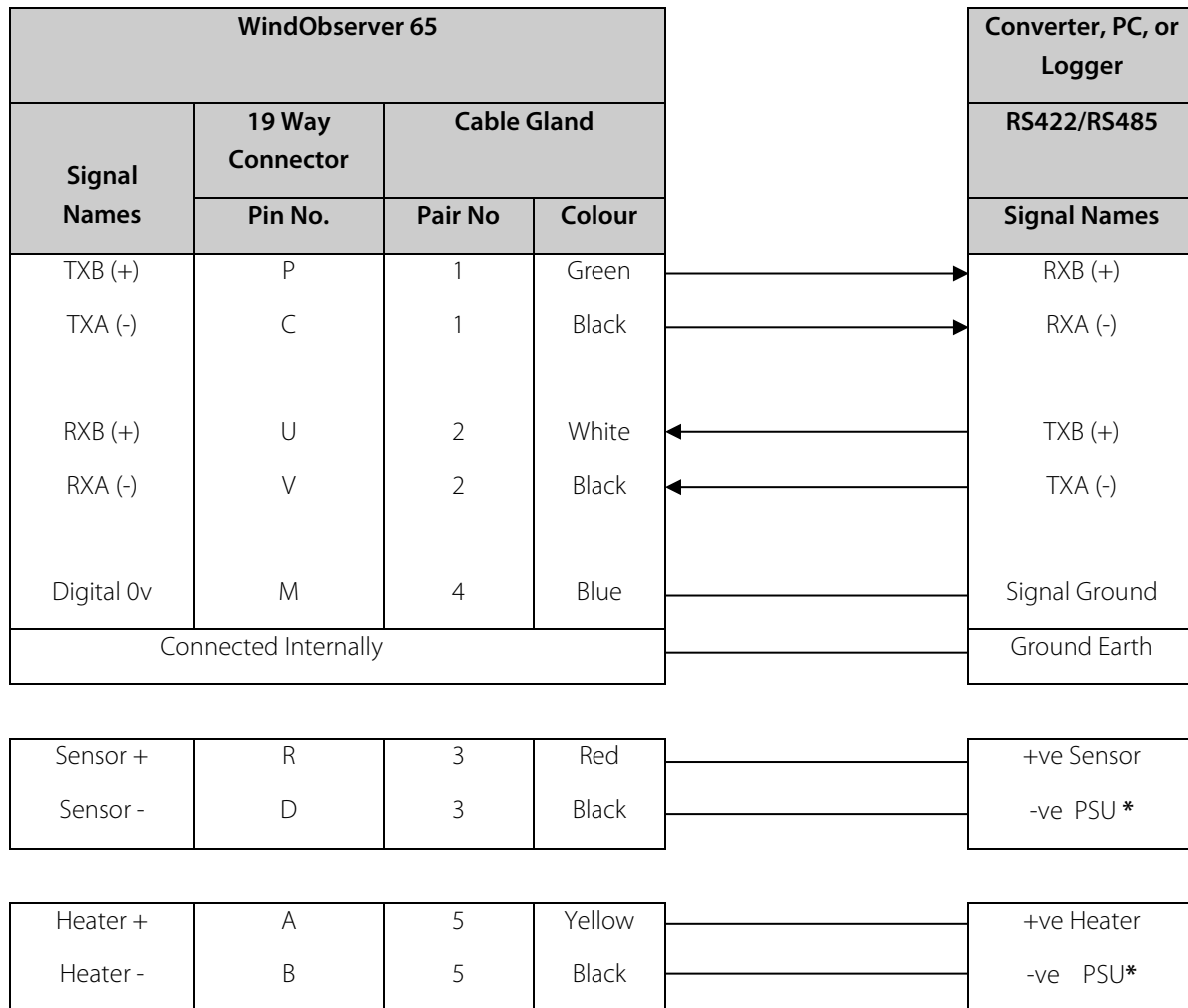

For Power Supply Information see Appendix A

Ultrasonic Anemometer

Appendix D - Networking

Before coupling units into a network:

- Each device must be configured with a unique Unit Identifier (letter A to Z) however in multi drop systems it could be advised to avoid using letters A-F, KMN and P as they could appear in the data string.
- Unit must be set for half duplex mode (E2 setting) see Half Duplex Operation (page 48).
- It must be configured to a tri-state polled mode [M3](#) or [M4](#).

See also Appendix F - Configuring

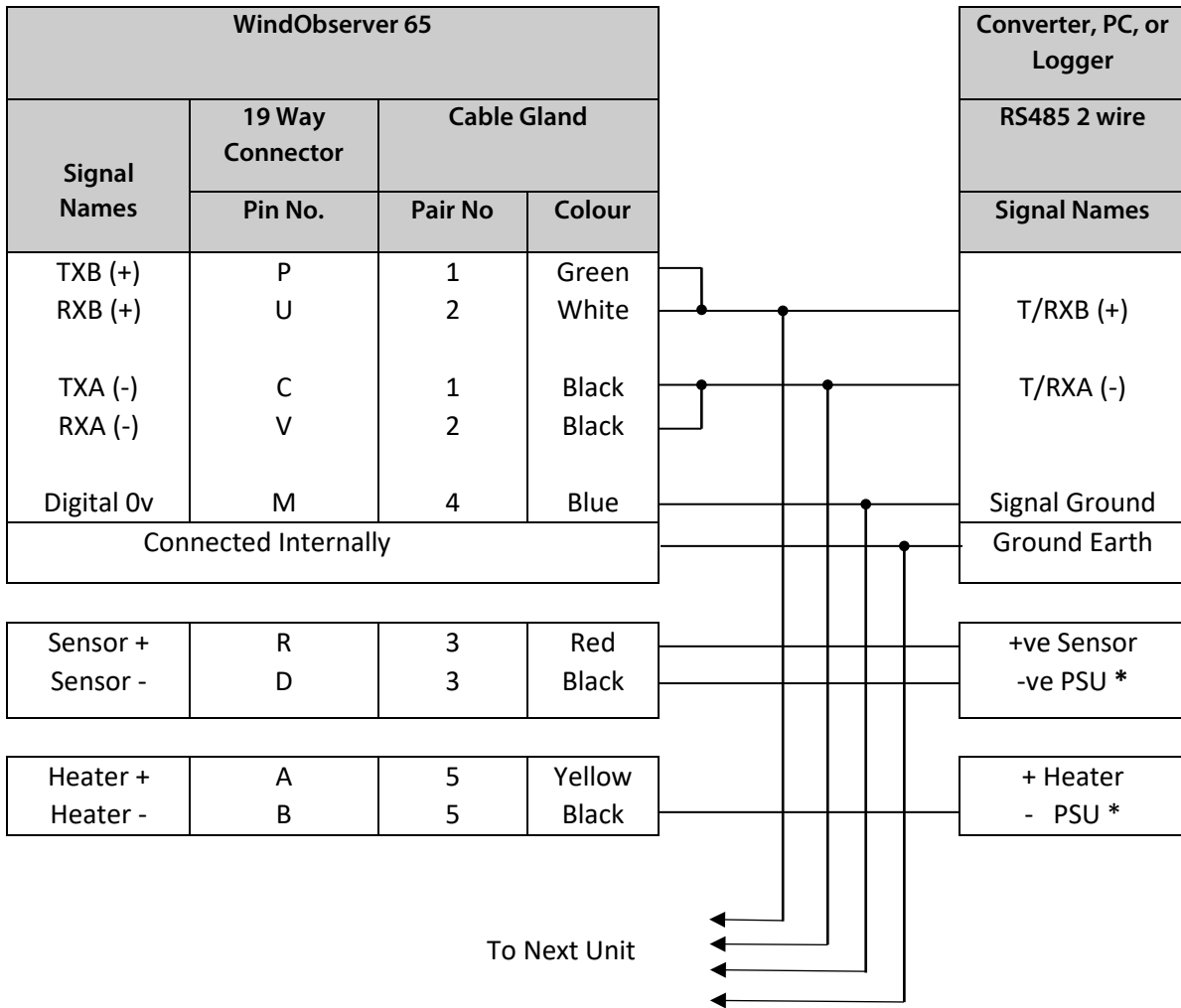

*For Power Supply Information see Appendix A.



Each unit in the network will require its own power supplies.

Ultrasonic Anemometer

Gill Proprietary Network

In these modes the communications transmit line is tri-state unless the anemometer is responding to a command. If used in a multi drop system then it is recommended that Unit Identifiers A, B, C, D, E, F, K, M, N and P are not used.

Equipment required for configuring full/half duplex:

- DC power supply, capable of providing 9 to 30vdc & 55mA.
- Pair of serial to USB adaptors, 1 for RS422 & 1 for 2-wire RS485.
- PC with a terminal package installed.



Power must not be disconnected from the anemometer throughout this procedure.

Configuring WindObserver 65 for Half Duplex Operation:

Process:

1. Connect both serial to USB adaptors to the PC and open a terminal connection for each one.
2. Connect the WindObserver to the power supply and wire the RS422 output to the RS422 adaptor (reference section xx for details).
3. Power up the WindObserver, data should begin scrolling in the RS422 terminal window.
4. Enter **configuration mode** (reference Appendix E for details) and type **E2 <ENTER>** to set half duplex. The **confirm** prompt will appear.
5. Disconnect the WindObserver from the RS422 adaptor and connect it to the RS485 adaptor. **Power must remain to the WindObserver at this point.**
6. In the RS485 terminal window type **E <ENTER>** to confirm. The WindObserver will now be set for half duplex.

Configuring WindObserver 65 for Full Duplex Operation:

1. Follow steps 1 & 2 above.
2. Connect the WindObserver to the RS485 adaptor and in the terminal window place the unit into **configuration mode**.
3. Type **E1 <ENTER>** to set full duplex, the **confirm** prompt will appear.
4. Disconnect the WindObserver from the RS485 adaptor and connect it to the RS422 adaptor. **Power must remain to the WindObserver at this point.**

In the RS422 terminal window type **E <ENTER>** to confirm. The WindObserver will now be set to full duplex.

Ultrasonic Anemometer

Appendix E - WindObserver 65 Safe Mode



If a unit is received that will not communicate or the configuration settings are not known, then Safe Mode can be used to establish communication with the WindObserver 65 and change configuration settings.

Initial Set Up.

The WindObserver 65 RS422 Pair 1 and Pair 2 TX and RX output connections (4 wires) are connected to a PC via an RS422 to RS232/USB Converter.

Open a Terminal program e.g., TeraTerm or puTTY (or use Gill Wind Software as a Terminal program).

Select the required COM port.

Set the Baud rate to 19200 baud (if using the Wind Terminal program it opens at 19200 baud).

To Place the unit into Safe Mode.

Turn off the WindObserver 65.

Ensure the Terminal program is set for 19200 baud,

Hold down the PC keyboard * key and turn on the WindObserver 65 Power Supply.

The words SAFE MODE should appear on the terminal screen.

If not then power down the WindObserver 65, hold the * key and re-power sensor.

To now check the unit: -

Type D1 and press Enter, to see serial number.

Type D2 and Press Enter to see Firmware version.

Type D3 to see configuration settings,

```
SAFE MODE
D1
F922036
D1
D2
5.00
D2
D3
current configuration :
A0 B2 C1 E1 F1 G0000 H2 J1 K1 L1 M5 NA O2 P1 T1 U1 V1 X1 Y1 Z1
```

Change settings if required.

Type Q and press Enter to go back into measurement mode.

If powering down the instrument and repowering and no change has been made to the baud rate (B command) then open a new terminal program at the units original baud rate setting (the default setting would be 9600 Baud).

Ultrasonic Anemometer

Appendix F - Configuring



The WindObserver 65 can be configured using Terminal emulator software such as HyperTerminal. Alternatively, it is possible to use Gill Wind Software as a Terminal program only (Wizard and Sync Comms not applicable). Wind will run on PC's up to and including Windows 10 and can be downloaded from:- <http://www.gillinstruments.com/main/software.html>.

Configuring using Terminal Program



Note – Most terminal emulators are configured in a very similar way.

1. Decide on an available Com port that you want to use (Usually Com1).
2. Run preferred terminal package such as Wind,Tera Term, puTTY etc.
3. Create a New Connection (File → New Connection)
4. Enter a **Name** (eg WindObserver 65).
5. Change '**Connect Using**' to 'Direct to Com 1' (or other Com port as required)
6. Adjust the Port settings to match WindObserver settings. WindObserver default settings are :

Bits per second 9600

Data bits 8

Parity None

Stop bits 1

Flow Control (Handshaking) None

Click on OK and data similar to the following example will scroll on screen at the output rate:

☺A, 229, 002.74, M, 00, ♥06

Entering Configuration mode

From Continuous mode

Type *

From Polled mode

Type *N - where N is the Unit Identifier.



- the Unit Identifier must be entered as upper-case

The WindObserver 65 responds with a CONFIGURATION MODE message, stops reporting wind measurements, and waits for a command (as detailed below).

Ultrasonic Anemometer



Returning to Measurement mode

Type Q and press ENTER

If in **Continuous** mode, the anemometer responds with wind measurements immediately, continuing at the selected Sampling rate.

If in **Polled** mode,

? Enables poll

N Polls anemometer (where N is the Unit identifier entered as upper-case)

The anemometer replies with a single set of wind measurements

& Anemometer replies with Unit identifier

! Disables poll

Note:- If the unit is in Polled Mode it is always best to interrogate the unit for data with a ? Before the poll identifier to cater for the event that the power has been switched off or power interrupted.

If used in a multi drop system then it is recommended that Unit Identifiers A, B, C, D, E, F, K, M, N and P are not used.

Checking the configuration

We strongly recommend that, as a standard procedure, you use this command (**D3**) prior to, and after, changing any settings. It shows the current settings for all the alterable settings. We suggest you note down your settings, so that you can easily return to them.

Type * Enters Configuration Mode (from Continuous mode)

Or Type *N Enters Configuration Mode (from Polled mode)

Type D3 and press ENTER The WindObserver 65 responds with the current configuration settings.

The factory default settings for a heated unit are:-

A0 B3 C1 E1 F1 G0000 H2 J1 K1 L1 M2 NA O1 P1 T1 U1 V1 X1 Y1 Z1

Or factory default settings for an unheated Unit are:-

A0 B3 C1 E1 F1 G0000 J1 K1 L1 M2 NA O1 P1 T1 U1 V1 X1 Y1 Z1

To return to Measurement mode Type Q and press ENTER How to change these settings is explained in the following sections.

Ultrasonic Anemometer

Configuration Settings

Ax – N/A

Bx - Baud Rate

Setting	Configuration code
2400	B1
4800	B2
9600	B3
19200	B4
38400	B5
1200	B6

To change the Baud rate when using HyperTerminal: -
 Eg. If set to B3 (9600 baud) and it is required to set to Baud rate to B2 (4800 baud).
 Type **[F4]** to enter Configuration Mode.
 Type **[B]** **[2]** and press **[ENTER]** (**Do not type any further commands at this stage**)
 Close the 9600 Baud HyperTerminal connection.
 Open HyperTerminal and set the new connection Baud Rate to 4800 baud.
 Type **[B]** and press **[ENTER]**, the letter B will be shown followed by B2
 Type **[Q]** and press **[ENTER]**, data will scroll at the new baud rate.

Cx- Analogue Output Polar Mode Direction Wraparound

Setting	Configuration code
Wraparound (0 - 539°)	C1
Standard (0-360°)	C2

Ultrasonic Anemometer

Dx- Diagnostic and Configuration Command (see Appendix L) (Bench Test)

Each of these commands causes a response from the WindObserver 65.

Item	Command code	Typical response
Type and serial No.	D1	*12400001 (where * = E (Unheated unit), F = (Heated unit))
Software version	D2	6.01
Unit configuration	D3	Current configuration: A0 B3 C1 E1 F1 G0000 H2 J1 K1 L1 M2 NA O1 P1 T1 U1 V1 X1 Y1 Z1
Anemometer power supply voltage	D5	+29.8
Integrity check	D6	See Appendix K (Bench Test)
Reports direction with a resolution of 1 degree	DR0	
Reports direction with a resolution of 0.01 degree	DR2	



The commands DR0, DR2 are only available on units running firmware V6.09

(Serial numbers 20310001 onwards)

Ex - Full Duplex/Half Duplex Mode

Setting	Configuration code
Full duplex	E1
Half duplex	E2



Refer also to Appendix D, Networking.

Fx- Data and Parity Options

Setting	Configuration code
8 bits, no parity, 1 stop bit	F1
8 bits, even parity, 1 stop bit	F2
8 bits, odd parity, 1 stop bit	F3

Ultrasonic Anemometer



Note: If changing to F2, using a terminal program then when in configuration mode Type F2 and press Enter, close the terminal program and open a new one with F2 Even parity settings, then type F and press Enter.

Gx to Gxxxx - Averaging (Digital Outputs only)

Setting	Configuration code
Averaging (Default)	G0000

Enter the required averaging period in seconds as a four-figure number between 0000 and 3600.

Hx - Heating (If fitted)

Heating is autonomous and requires no set-up once activated.

Setting	Configuration code
Disabled	H1
Activated	H2

Jx - Analogue Power-up Tests (N/A)

Kx – NMEA Settings

Setting	Configuration code
NMEA string "IIMWV"	K1
NMEA string "WIMWV"	K2

Lx - ASCII Message Terminator

Setting	Configuration code
CR LF	L1
LF	L2

Ultrasonic Anemometer

Mx to Mxx - Message Format

Output format	Configuration code
ASCII UV Continuous	M1
ASCII Polar Continuous	M2
ASCII UV Polled (tri-state) *	M3
ASCII Polar Polled (tri-state) *	M4
NMEA Continuous	M5
Binary Tunnel Continuous	M6
Binary UV Continuous	M7
Binary Polar Continuous	M8
ASCII Tunnel Continuous	M12
ASCII Tunnel Polled (tri-state) *	M13
ASCII Polar Polled Averaged	M14
ASCII Polar Continuous Averaged	M15



* If units are to be networked, they MUST be given unique Unit Identifiers

Nx – Unit Identifier Address

Item	Options	Command
Unit Identifier Address	A... -(A to Z)	N<A>

If used in a multi-drop system then it is recommended that ID's A to F and K, M, N and P are not used, as these characters can be present in the data string.

Ultrasonic Anemometer

Ox – ASCII Output Format (Output String Padding)

Setting	Configuration code
Comma Separated Variable (CSV)	O1
Fixed Field	O2

Example data strings: -

POLAR	NMEA
CSV data changing to error status code condition.	CSV data changing to error status code condition.
A,235,000.77,M,00,0A	\$IIMWW,191,R,000.55,M,A*19
A,,,M,04,24	\$IIMWW,,R,,M,V*29
Fixed Field data changing to error status code condition.	Fixed Field data changing to error status code condition.
A,266,000.73,M,00,08	\$IIMWW,191,R,000.55,M,A*19
A,999,999.99,M,04,0A	\$IIMWW,999,R,999.99,M,V*07

Px - Output Rate

Outputs per second	1	2	4	5	8	10
Configuration code	P1	P3	P2	P4	P5	P6

Q- Measurement Mode

See page 51

RWASHORT XX (Short term number)

Where XX = 10 to 60, associated with Mode 14 and Mode 15 averaging.

RWALONG XX (Long term number)

Where XX = 1 to 10, associated with Mode 14 and Mode 15 averaging.

Tx - Analogue Output Voltage or Current settings (N/A)

Ultrasonic Anemometer

Ux – Digital Output Units

Units	metres/sec (m/s)	knots (knots)	miles / hour (MPH)	kilometre/hour (kph)	feet / minute (fpm)
Configuration code	U1	U2	U3	U4	U5

Vx- Vertical Output Padding

Setting	Configuration code
Disable vertical output padding	V1
Enable vertical output padding	V2

Xx - 45° Alignment Offset/Inverted Operation

Setting	Configuration code	Notes
Align U axis with transducer axis	X1	X1. Aligns U axis with North/South axis.
Align U axis +45° to transducer axis	X2	X2. This re-aligns both U&V and polarity 45° to transducer axis.
Reverses Polar Direction	X3	X3 reverses reported polar direction to allow the instrument to be mounted upside down. N.B. Does NOT affect UV alignment (Mode 1, 3).
Align @ 45° from North	X4	X4 set polar alignment at 45 degrees from North when instrument is mounted upside down. Does NOT affect UV alignment (Mode 1, 3).

Error! Reference source not found.4 shows the polarity of U and V if the wind components along the U and V axis are blowing in the direction of the respective arrows.

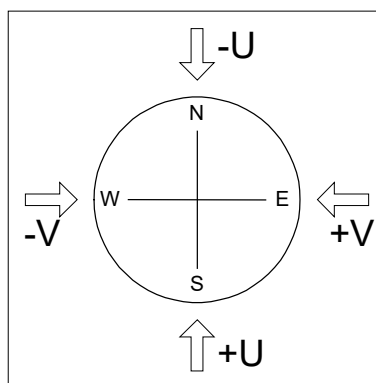

Figure 4 UV Polarity

Ultrasonic Anemometer

Appendix G - WindObserver 65 ASCII Data Output

WindObserver 65 default ASCII data

NODE, DIR, SPEED, PRESS, RH, TEMP, DEWPOINT, PRT, AN1, AN2, DIG1, VOLT, STATUS

<STX>Q,121,000.06,M,+344.66,+21.76,00 <ETX>06

Where:-

Start of String	STX
Q	Node letter
121	Wind direction
000.06	Wind speed
M	Units
+344.66	Speed of Sound
+021.76	Temperature
00	Status code
End of String	ETX
06	Checksum

NOTES:

<STX> is the Start of String character (ASCII value 2).

<ETX> is the End of String character (ASCII value 3).

Checksum, the 2 digit Hex Checksum sum figure is calculated from the Exclusive OR of the bytes between (and not including) the STX and ETX characters.

Ultrasonic Anemometer

Appendix H - WindObserver 65 NMEA 0183 Data Output

WindObserver 65 NMEA0183

When reporting in NMEA0183 format the following sentences will be used

- **MWV** sentence to report wind direction and speed

In each case *hh is a checksum, the 2 digit Hex Checksum sum figure is calculated from the Exclusive OR of the bytes between (and not including) the \$ and * characters.

<CR> is a Carriage return character (ASCII hex value d)

<LF> is a Line Feed Character (ASCII hex value a)

MWV - Wind direction/speed

```
      1 2   3 4 5  
      | |   | | |  
$- -MWV,x,a,x.x,a,*hh<CR><LF>
```

Field Number:

1. Direction
2. R - relative
3. Speed
4. Units N - Knots
5. Validity flag, A - Valid, V - invalid

Example

```
$WIMWV,105,R,000.03,N,V*1D
```

Ultrasonic Anemometer

Appendix I - Polled Mode Commands

ASCII Polled (UV and Polar)

When in the Polled mode, an output is only generated when the host system sends a Poll signal to the WindObserver consisting of the WindObserver Unit Identifier – that is, the relevant letter A – Z.

The output formats are otherwise as described above.

The commands available in this mode are:

Description	Command	WindObserver response
WindObserver Unit Identifier	A Z	Wind speed output generated
Enable Polled mode	?	(None)
Disable Polled mode	!	(None)
Request WindObserver Unit Identifier	&	A Z (as configured)
Enter Configuration mode	*<N>	CONFIGURATION MODE

Where <N> is the unit identifier, if used in a multi-drop system then it is recommended that ID's A to F and KMNP are not used as these characters can be present in the data string.

It is suggested that in polled mode the following sequence is used for every poll for information.

- ? Ensures that the Sensor is enabled to cover the event that a power down has occurred.
- A-Z Appropriate unit designator sent to retrieve a line of data.
- ! Sent to disable poll mode and reduce possibility of erroneous poll generation.

When in polled mode the system will respond to the data command within 30mS with the last valid data sample as calculated by the Output rate (P Mode Setting).

If the unit is powered down after use or upon switch on then allow 3 seconds from switch on before sending poll commands.

Ultrasonic Anemometer

Appendix J - WindView Software

Introduction

Gill WindView Software can be downloaded from <http://gillinstruments.com/main/software.html>

Gill Wind View will run on PC's with Windows XP onwards operating systems.



Connect to an Instrument using Gill WindView Software

Open WindView Software.

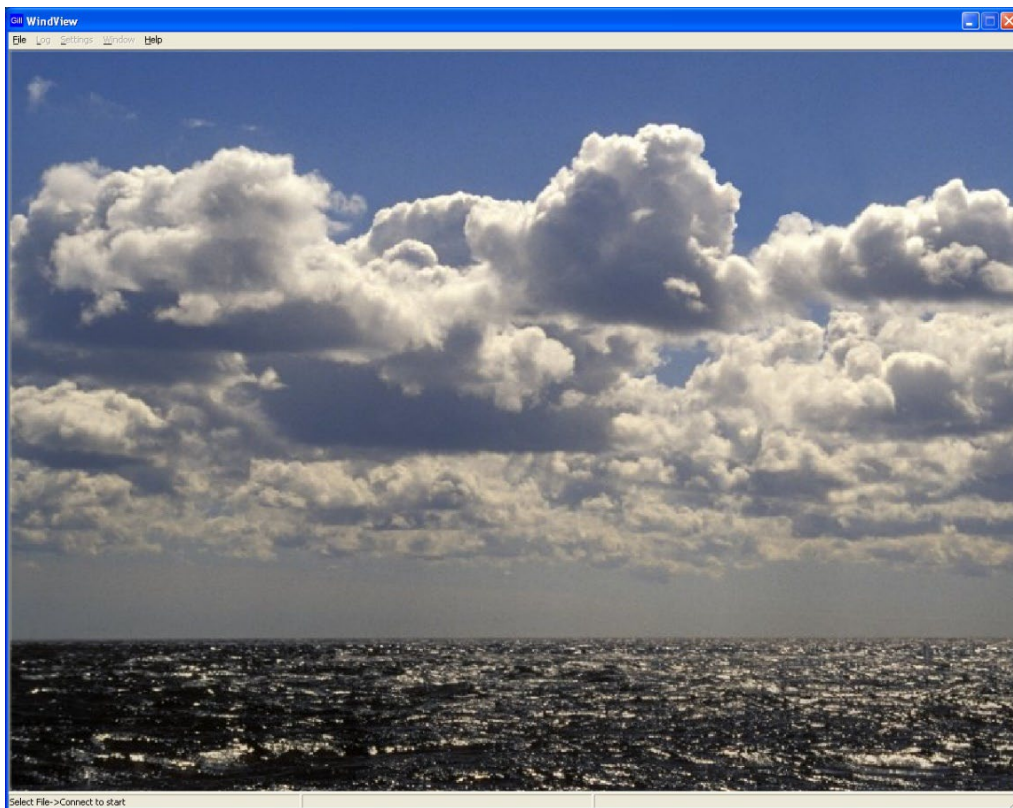

Ultrasonic Anemometer

Select File/Connect.

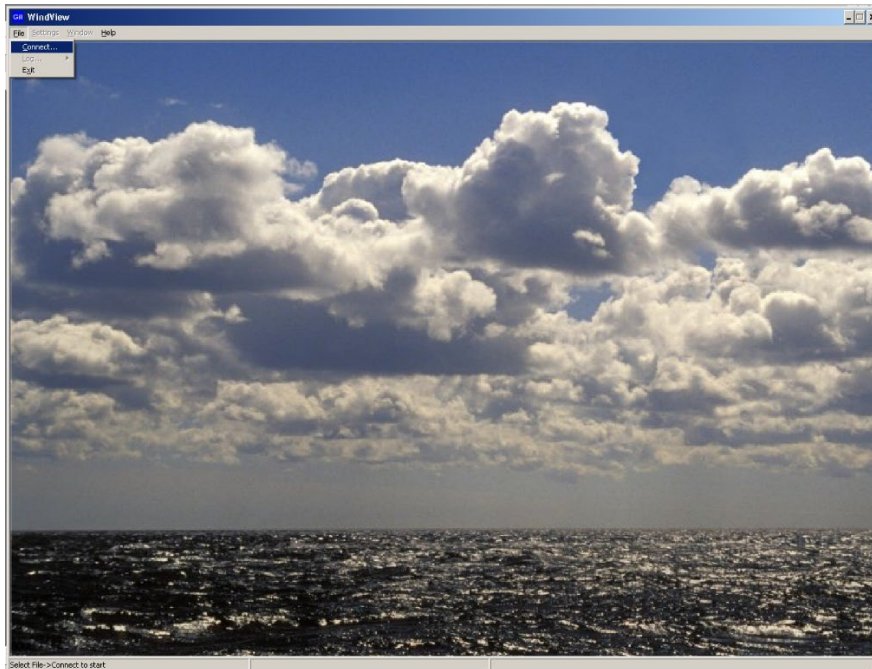

The default connection name is Anemometer 1, it can be re-named if required.

Select the Output Format to match the Sensor format i.e. the WindObserver default format is Gill Polar (2 axis).

If the WindObserver were set for UV or NMEA output then choose the appropriate format setting from the drop down menu.

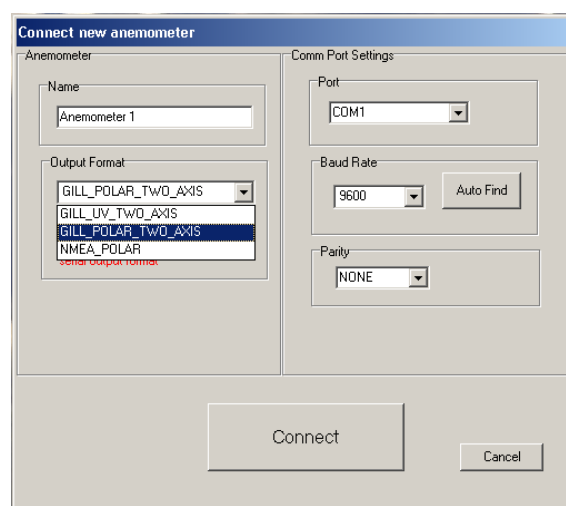

Ultrasonic Anemometer

From the Port drop down menu select the PC COM Port to which the WindObserver is connected to e.g. COM 9.

Select the Baud rate setting from the drop down menu to match that of the Windobserver, the WindObserver default baud rate is 9600 baud.

Leave Parity setting at none.

Click on Connect.

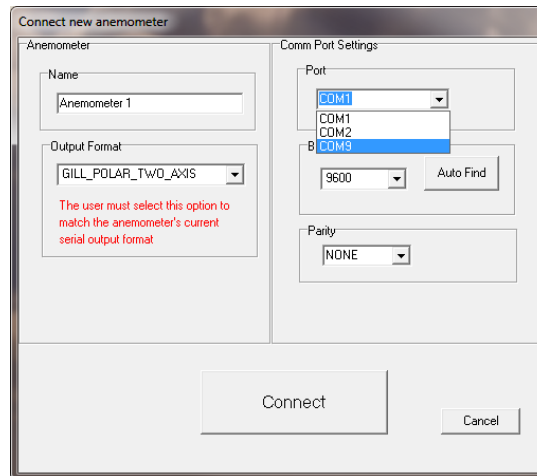

The Data button screen will show the WindObserver data scrolling on screen updated at the WindObserver Output rate.

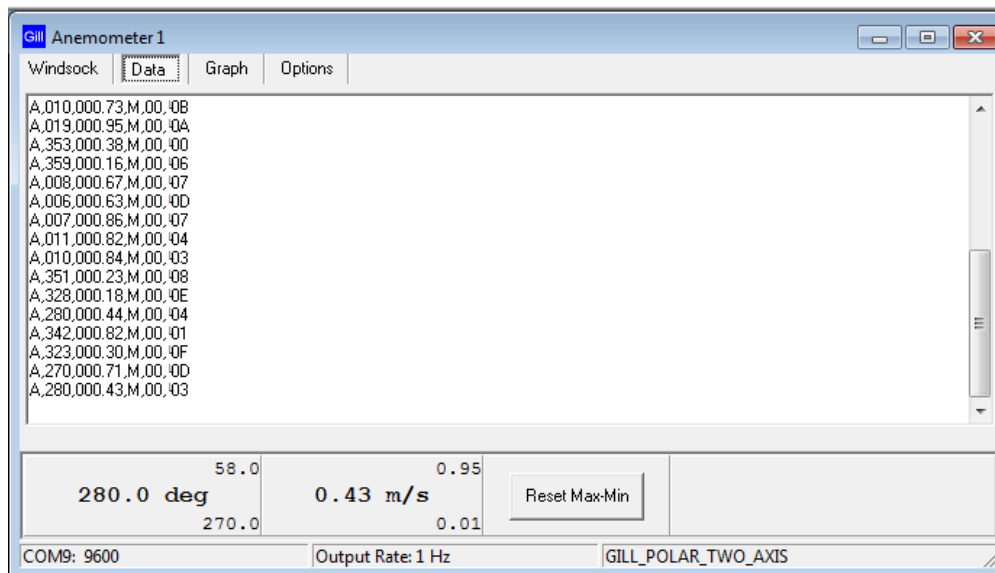

Ultrasonic Anemometer

WindSock Function

Click on the WindSock button to give a Direction display and digital readout of Direction and Wind Speed:-
On screen Maximum and Minimum readings of Wind speed and Directions are also displayed digitally and can be reset using the Reset Max/Min button.

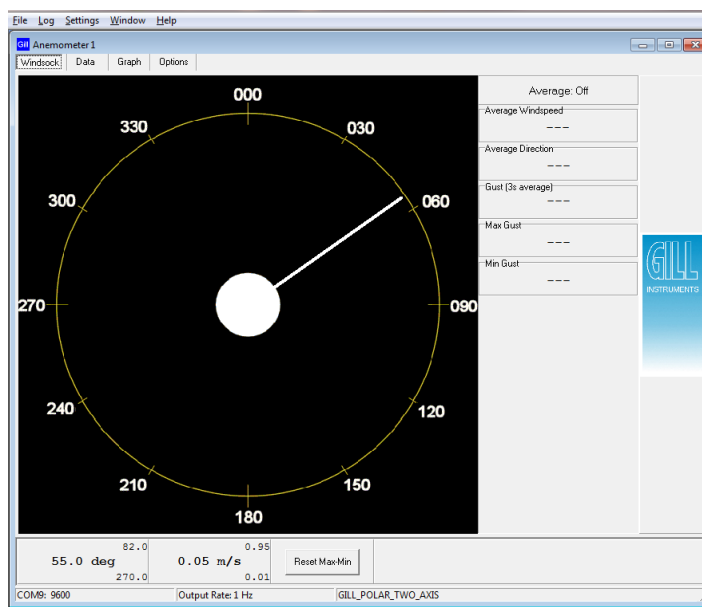

Logging Data

To Log WindObserver data, from the WindView top menu select Settings/Logging.
If segmented log files are required tick the Enable box and select the length of each log file.
Tick the Record Formatting box options for Appending PC Time and Date Stamp and sequential line numbering as required.
Date and Time are taken from the PC clock.
The Log Description box allows a free text file header to be added to the log file.
Save the Log file to the required Directory.

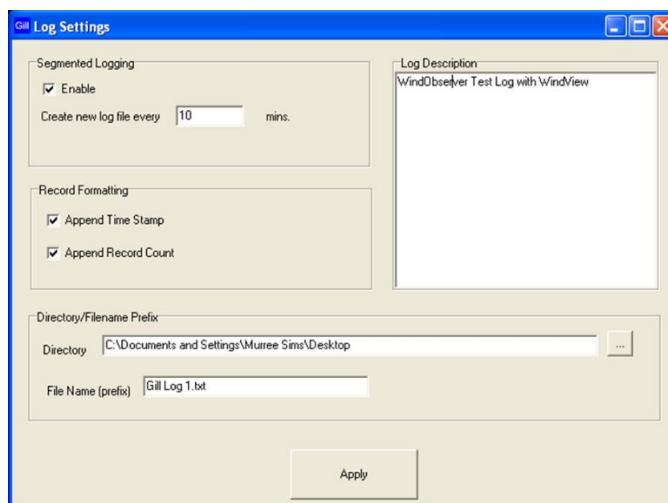

Ultrasonic Anemometer

Click on Apply gives the following screen, click on OK:-

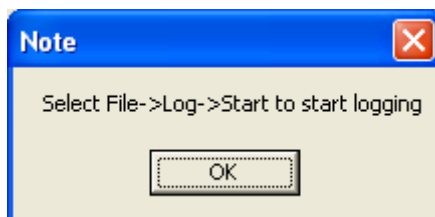

To Start Logging.

From the top menu select Log.

Click on Log/Start to commence logging.

To Stop Logging.

From the top menu select Log.

Click on Log/Stop to stop logging.

The logged data is saved to a PC text file that can be opened with Notepad or equivalent and the following example illustrates the saved time/date stamped WindObserver data.



The Date and time information are taken from the PC Clock.

```
Gill Log 1 [Anemometer 1]-0.txt - Notepad
File Edit Format View Help
windview Log File
windobserver Test Log with windview
Name: Anemometer 1
Output Format: GILL_POLAR_TWO_AXIS
Log file opened: 06/10/2010 08:38:30

A, 351,000.02,M, 60, 00D,1,06/10/2010 08:38:31
A, 351,000.02,M, 60, 00D,2,06/10/2010 08:38:32
A, 351,000.01,M, 60, 00E,3,06/10/2010 08:38:33
A, 351,000.01,M, 60, 00E,4,06/10/2010 08:38:34
A, 351,000.00,M, 60, 00F,5,06/10/2010 08:38:35
A, 351,000.02,M, 60, 00D,6,06/10/2010 08:38:36
A, 351,000.02,M, 60, 00D,7,06/10/2010 08:38:37
A, 351,000.01,M, 60, 00E,8,06/10/2010 08:38:38
A, 351,000.01,M, 60, 00E,9,06/10/2010 08:38:39
A, 351,000.01,M, 60, 00E,10,06/10/2010 08:38:40
A, 351,000.00,M, 60, 00F,11,06/10/2010 08:38:41
A, 351,000.01,M, 60, 00E,12,06/10/2010 08:38:42
A, 351,000.01,M, 60, 00E,13,06/10/2010 08:38:43
A, 351,000.00,M, 60, 00F,14,06/10/2010 08:38:44
A, 351,000.00,M, 60, 00F,15,06/10/2010 08:38:45
```

The logged Wind Data .txt file can be imported into Microsoft Excel if it is required to manipulate the data or graph plot the data.

Appendix K - WindObserver 65 Status Codes

WindObserver 65 is able to include a status code in each measurement string to confirm the reliability of the data or to highlight any potential issues. A list of the status code is provided below.

Code	Status	Description
00	OK	No fault conditions detected in measurement period
60	OK and heating enabled	Sufficient samples in average period
A	OK	NMEA data Acceptable
01	Axis 1 failed	Insufficient samples in average period on U axis
02	Axis 2 failed	Insufficient samples in average period on V axis
04	Axis 1 and 2 failed	Insufficient samples in average period on both axis
08	NVM error	NVM checksum failed, data could be uncalibrated
09	ROM error	ROM checksum failed, data could be uncalibrated
51	Measurement average building	Data valid but warns that average period not reached when averaging used (non-heat enabled units only)
62	Heating current tripped or electronic failure	Valid data still output
63	Heater Thermistor open circuit	Valid data still output
65	Heating element open circuit	Valid data still output
V	NMEA data void	Invalid data output

Ultrasonic Anemometer

Appendix L - Maintenance & Fault-Finding

Cleaning and Handling

When installing the unit handle with lint free gloves and degrease the unit to reduce the build-up of deposits.

If there is any build-up of deposit on the unit, it should be gently cleaned with a cloth, moistened with soft detergent. Solvents should not be used, and care should be taken to avoid scratching any surfaces. The unit must be allowed to defrost naturally after being exposed to snow or icy conditions, do NOT attempt to remove ice or snow with a tool.



Do NOT remove black “rubber” transducer caps.

Servicing

There are no moving parts or user-serviceable parts requiring routine maintenance.

Opening the unit or breaking the security seal will void the warranty and the calibration.

In the event of failure, prior to returning the unit to your authorised Gill distributor, it is recommended that:

- All cables and connectors are checked for continuity, bad contacts, corrosion etc.
- A bench test is carried out as described on page 68
- Contact your supplier for advice if failure persists.

Symptom	Solution
No output	<p>Check DC power to WindObserver 65, cable and connections.</p> <p>Check comms settings of WindObserver 65 (as detailed in Appendix F) and host system match, including correct Com port.</p> <p>Check unit is in Continuous mode.</p> <p>Check that in-line communication devices are wired correctly.</p> <p>NOTE: It is usual for Anemometer TX + to be connected to converter device RX +.</p>
Corrupted output	<p>Check comms settings of WindObserver 65 and host system match.</p> <p>Try a slower baud rate.</p> <p>Check cable lengths and type of cable.</p>
One way communication	<p>Check wiring is in accordance with the manual.</p>
Failed / Incorrect WindObserver 65 output, data invalid flag	<p>Check that transducer path is not blocked.</p>

Ultrasonic Anemometer

Bench Test

1. Couple the WindObserver 65 to the host system and power supply, using a known working test cable.
2. Check that the unit is correctly configured by going into Configuration mode and using [D3](#) See *Appendix F (page 49) Checking the Configuration*.
3. Check for normal output data, and that the Status Code is OK – 00, 60 or A (for NMEA format).
4. If the status code is other than these, refer to Appendix K Status (error) codes.
5. Use an office fan or similar to check that the unit is sensing wind, turning the unit to simulate changing wind direction and to check that both axes are functioning.
6. Note that this is a quick functional test. There are no calibration adjustments; the unit is designed NOT to require re-calibration within its lifetime. Gill has provided an Integrity Check, see next page for details.

Use of an Integrity Check Chamber (Optional item)

The ICC is designed to:

1. Identify any gross changes in the head geometry that would affect the performance.
2. Provide a zero wind environment to confirm the WindObserver 65 zero calibration.

The ICC has been designed to be used in an indoor still air environment with an ambient temperature between 17°C and 23°C. When conducting the test it is important that the ICC is assembled on to the WindObserver 65 head and not touched or moved during the test.

This test is only valid if undertaken with an ICC purchased from Gill.

Note:- The Heater supply should be disconnected or turned off when using the ICC.

Zero Wind Check

Configure your PC to run HyperTerminal and assemble the ICC by inserting the reflector cases and the two halves of the ICC onto the WindObserver 65. The ICC must be retained using the strips provided. Then:

1. Ensure that the WindObserver 65 is set in factory default mode. For Factory default settings see section Appendix F (page 49)
2. Enter Measurement Mode and Record/View data

In still air wind speed measurements should not exceed 0.03m/s. If wind speed exceeds 0.03m/s contact Gill Instruments.

Ultrasonic Anemometer

Alignment Check

Ensure the ICC is assembled correctly on the WindObserver 65. Using Terminal Program, enter Configuration Mode as described in Section 8.

Enter D6.

A typical report as shown below will be displayed.

```
D6
ALIGNMENT LIMITS: U=2424, 2524
                  V=2434, 2434
ALIGNMENT U: 2474 *PASS*
ALIGNMENT V: 2484 *PASS*
```

D6

If 'Refer to Manual' is shown check test temperature conditions are 17 to 23 deg C and tested under zero wind condition.

If there has been no significant changes to The WindObserver 65 head configuration then *PASS* will confirm correct operation.

Alterations to the head geometry can result in a *FAIL* or 'Insufficient Samples' message. If this occurs please contact Gill Instruments.

Appendix M - Glossary & Abbreviations

Item	Meaning
CAL	Calibration
CR	Carriage Return
CRLF	Carriage Return Line Feed
CSV	Comma Separated Variable
ENG	Engineering
ESC	ESCape key on keyboard used to stop any process that is being executed
ETX	End of string character
FAC	Factory
fpm	Feet per minute
GND	GrouND
HEX	HEXadecimal
I/P	InPut
IP66	Protection Classification
KPH	Kilometres per Hour
LF	Line Feed
m/s	Metres per second
MAG	MAGnitude - scalar reference to wind speed
MAX	MAXimum
MPH	Miles per Hour
NEMA	National Electrical Manufacturers Association
NMEA 0183 (version 3)	National Marine Electronics Association standard for interfacing marine electronic navigational devices
No:	Number
NVM	Non-Volatile Memory
O/P	Output
PC	IBM compatible Personal Computer
PCB	Printed Circuit Board
POR	Power On Reset
ROM	Read Only Memory
RS232	Communications standard

Ultrasonic Anemometer

Item	Meaning
RS422	Communications standard
RS485	Communications standard
RTS	Request To Send
RWA	Road Weather Averaging
RX	Receive
RXD	Received Data
S/W	SoftWare
SOS	Speed Of Sound
SEC	SECond
STX	Start of string character
TERM	TERMinal
TX	Transmit
TXD	Transmitted Data
+VE	Positive
-VE	Negative
WRT	With Respect To

Ultrasonic Anemometer

Appendix N - Guarantee & FCC

For terms of guarantee contact your supplier or refer to the Gill Instruments Terms & Conditions here:

<https://gill.group/wp-content/uploads/Gill-Group-Company-Terms-Conditions-of-Sale-9170-0003-Issue-02-March-20...pdf>

Warranty is void if the green security seal covering base nuts is damaged or broken, or the transducer caps have been damaged.

FCC

WindObserver 65 complies with part 15 of the FCC Rules. Operation is subject to the following two conditions:-

- (1) This device may not cause harmful interference, and
- (2) This device must accept any interference received, including interference that may cause undesired operation.

This equipment has been tested and found to comply with the limits for a Class A digital device, pursuant to part 15 of the FCC Rules. These limits are designed to provide reasonable protection against harmful interference when the equipment is operated in a commercial environment. This equipment generates, uses, and can radiate radio frequency energy and, if not installed and used in accordance with the instruction manual, may cause harmful interference to radio communications. Operation of this equipment in a residential area is likely to cause harmful interference in which case the user will be required to correct the interference at his own expense.

Ultrasonic Anemometer

Appendix O - Principle of operation

The WindObserver 65 measures the times taken for an ultrasonic pulse of sound to travel from the North transducer to the South transducer, and compares it with the time for a pulse to travel from S to N transducer. Likewise times are compared between West and East, and E and W transducer.

If, for example, a North wind is blowing, then the time taken for the pulse to travel from N to S will be faster than from S to N, whereas the W to E, and E to W times will be the same. The wind speed and direction (and the speed of sound) can then be calculated from the differences in the times of flight on each axis. This calculation is independent of factors such as temperature.

