

### Ultrasonic Anemometer

(Parts 1390-PK-006, 1390-PK-007, 1390-PK-026 and 1390-PK-027)

Doc No: 1390-PS-0004

Issue 28 (Applies to firmware 2387 6.09 onwards).



Gill Instruments Limited  
Saltmarsh Park, 67 Gosport Street, Lymington,  
Hampshire, SO41 9EG, UK  
Tel: +44 1590 613500, Fax: +44 1590 613555  
Email: [anem@gillinstruments.com](mailto:anem@gillinstruments.com) Website: [www.gillinstruments.com](http://www.gillinstruments.com)

# Contents

|           |   |           |
|-----------|---|-----------|
| <b>1.</b> | <b>FOREWORD.....</b>  | <b>5</b>  |
| <b>2.</b> | <b>INTRODUCTION.....</b>  | <b>5</b>  |
| <b>3.</b> | <b>FAST TRACK SET-UP .....</b>                                    | <b>5</b>  |
| <b>4.</b> | <b>SPECIFICATION .....</b>  | <b>6</b>  |
| <b>5.</b> | <b>PRE-INSTALLATION .....</b>                                     | <b>7</b>  |
| 5.1.      | Equipment supplied .....  | 7         |
| 5.2.      | Installation requirements.....                                    | 7         |
| <b>6.</b> | <b>INSTALLATION.....</b>  | <b>9</b>  |
| 6.1.      | Installation Guidelines.....                                      | 9         |
| 6.2.      | Bench system test .....   | 10        |
| 6.3.      | Cabling .....   | 10        |
| 6.4.      | Power supplies .....  | 11        |
| 6.5.      | Connections.....  | 12        |
|           | Default Settings.....   | 13        |
|           | Connecting to a PC with a RS422 or RS485 input.....               | 14        |
|           | Networking units .....  | 15        |
|           | Connecting to a PCI Unit with RS422 input.....                    | 16        |
| 6.6.      | Indoor Power and Communications Interface (Part 1189-PK-021)..... | 16        |
|           | PCI Electrical Power Requirements.....                            | 16        |
|           | PCI Connector Pin and Cable assignments .....                     | 17        |
|           | Anemometer connector – 15 way .....                               | 17        |
|           | Auxiliary Analogue Outputs – 9 way .....                          | 17        |
|           | DC Supply – 4 way .....   | 17        |
|           | RS 232 Output – 9 way.....  | 18        |
|           | RS422 Network In – 9 way Skt.....                                 | 18        |
|           | RS422 Network Out – 9 way Plg .....                               | 18        |
| 6.7.      | Analogue connections.....   | 19        |
|           | Analogue Voltage Output Connections (5v or $\pm 2.5v$ ) .....     | 19        |
|           | Analogue Connections for 4-20mA output.....                       | 19        |
| 6.8.      | Using the WindObserver II with WindDisplays .....                 | 20        |
| 6.9.      | Mechanical installation.....                                      | 24        |
|           | Location .....  | 24        |
|           | Orientation .....   | 24        |
|           | Mounting bracket .....  | 24        |
|           | Alignment.....  | 26        |
|           | Figure 2b WindObserver II outline dimensions.....                 | 27        |
| <b>7.</b> | <b>MESSAGE FORMATS &amp; OPTIONS.....</b>                         | <b>28</b> |
| 7.1.      | Wind Speed format .....   | 28        |
| 7.2.      | Output formats.....   | 28        |
|           | Low wind speeds .....   | 28        |
| 7.3.      | Networking.....   | 29        |
| 7.4.      | Units .....   | 30        |
| 7.5.      | Output rate.....  | 30        |
|           | Sample Average .....  | 30        |
| 7.6.      | Averaging (Digital Data).....                                     | 30        |
|           | 8.6.1 G Command Averaging.....                                    | 30        |
|           | 7.6.2 Modes 14 and 15 Road Weather Averaging (RWA).....           | 31        |
| 7.7.      | Options .....   | 34        |
|           | Speed of Sound (SOS) and Temperature .....                        | 34        |

|           |   |           |
|-----------|---|-----------|
|           | Heating (If fitted) .....   | 34        |
|           | 45° Offset .....  | 34        |
|           | Vertical Output Padding .....                                     | 34        |
| 7.8.      | ASCII message format (UV, Polar and Tunnel).....                  | 35        |
|           | ASCII UV format .....   | 35        |
|           | ASCII Polar format .....  | 36        |
|           | ASCII Polled (UV and Polar).....                                  | 36        |
|           | ASCII format – Tunnel Mode .....                                  | 37        |
| 7.9.      | Binary message format (UV, Polar and Tunnel).....                 | 38        |
|           | Binary UV format.....   | 38        |
|           | Binary Polar format .....   | 38        |
|           | Binary Tunnel format.....   | 39        |
| 7.10.     | NMEA Format.....  | 40        |
| 7.11.     | Averaging Format (Modes 14 and 15).....                           | 41        |
| 7.12.     | Analogue outputs and options.....                                 | 42        |
|           | Output modes .....  | 42        |
|           | Channel outputs .....   | 42        |
|           | Status .....  | 42        |
|           | Temperature .....   | 42        |
|           | Tunnel mode .....   | 42        |
|           | Scaling .....   | 42        |
|           | Averaging.....  | 42        |
|           | Polar mode direction wraparound.....                              | 43        |
|           | Low wind speeds .....   | 43        |
|           | Cables.....   | 43        |
| <b>8.</b> | <b>CONFIGURING.....</b>   | <b>44</b> |
| 8.1.      | Configuring using HyperTerminal.....                              | 44        |
| 8.2.      | Entering Configuration mode .....                                 | 44        |
| 8.3.      | Returning to Measurement mode.....                                | 44        |
| 8.4.      | Checking the configuration .....                                  | 45        |
| 8.5.      | Changing settings .....   | 45        |
| 8.6.      | Configuration Settings.....                                       | 46        |
|           | Ax - Speed of Sound (SOS) and Temperature .....                   | 46        |
|           | BX - Baud Rate .....  | 46        |
|           | Cx- Analogue Output Polar Mode Direction Wraparound.....          | 46        |
|           | Dx- Diagnostic and Configuration Command .....                    | 47        |
|           | Ex - Full Duplex/Half Duplex Mode.....                            | 47        |
|           | Fx- Data and Parity Options .....                                 | 47        |
|           | Gx to Gxxxx - Averaging (Digital Outputs only) .....              | 47        |
|           | Hx - Heating (If fitted).....                                     | 48        |
|           | Jx - Analogue Power-up Tests.....                                 | 48        |
|           | Kx – NMEA Settings .....  | 48        |
|           | Lx - ASCII Message Terminator .....                               | 48        |
|           | Mx to Mxx - Message Format .....                                  | 48        |
|           | Nx – Unit Identifier Address .....                                | 49        |
|           | Ox – ASCII Output Format (Output String Padding).....             | 50        |
|           | Px - Output Rate .....  | 50        |
|           | Q- Measurement Mode .....   | 50        |
|           | Tx - Analogue Output Voltage or Current settings (if fitted)..... | 50        |
|           | Ux – Digital Output Units.....                                    | 50        |
|           | Vx- Vertical Output Padding .....                                 | 51        |
|           | Xx - 45° Alignment Offset/Inverted Operation .....                | 51        |
|           | Yx – Analogue Output, Channel 3 (if fitted). .....                | 51        |
|           | Zx – Analogue Output Scaling (if analogue outputs fitted). .....  | 51        |
| <b>9.</b> | <b>VIEW AND LOG DATA WITH WINDVIEW SOFTWARE .....</b>             | <b>52</b> |
| 9.1.      | Introduction.....   | 52        |

---

|            |  |           |
|------------|--|-----------|
| 9.2.       | Connect to an Instrument using Gill WindView Software..... | 52        |
| 9.3.       | WindSock Function.....                                     | 54        |
| 9.4.       | Logging Data. ....   | 55        |
| <b>10.</b> | <b>MAINTENANCE &amp; FAULT-FINDING .....</b>               | <b>57</b> |
| 10.1.      | Cleaning and Handling.....                                 | 57        |
| 10.2.      | Servicing.....   | 57        |
| 10.3.      | Fault-finding.....   | 57        |
| 10.4.      | Safe Mode .....  | 58        |
| 10.5.      | Returning unit .....                                       | 59        |
| 10.6.      | Status (error) codes .....                                 | 59        |
| 10.7.      | Bench test.....  | 59        |
|            | Integrity Check Chamber (ICC) .....                        | 60        |
|            | Integrity & Zero Wind Check.....                           | 60        |
| <b>11.</b> | <b>APPENDICES.....</b>                                     | <b>61</b> |
| 11.1.      | Glossary & Abbreviations.....                              | 61        |
| 11.2.      | Guarantee.....   | 62        |
| 11.3.      | Principle of operation .....                               | 63        |
| <b>12.</b> | <b>FCC.....</b>  | <b>64</b> |

## 1. FOREWORD

Thank you for purchasing the WindObserver II manufactured by Gill Instruments Ltd. The unit has no customer serviceable parts and requires no calibration or maintenance. To achieve optimum performance we recommend that you read the whole of this manual before proceeding with use. Do **NOT** remove black “rubber” transducer caps.

Gill products are in continuous development and therefore specifications may be subject to change and design improvements without prior notice.

The information contained in this manual remains the property of Gill Instruments and should not be copied or reproduced for commercial gain.

## 2. INTRODUCTION

The Gill WindObserver II wind sensor is a very robust, lightweight unit with no moving parts, outputting wind speed and direction. The units of wind speed, output rate and formats are all user selectable.

The WindObserver II is available with or without de-icing heating (recommended if icing is likely), and with or without analogue outputs.

The WindObserver II can be used in conjunction with a PC, data logger or other device, provided it is compatible with the RS422 output or the analogue outputs. Multiple units can be networked if required.

Alternatively, the WindObserver II is designed to connect directly to the Gill WindDisplay unit to provide a complete wind speed direction system without any configuration required by the user.

The output message format can be configured in Polar, UV (2-axis), NMEA (0183 Version 3), Tunnel formats, and as either a Continuous output or Polled (requested by host system), detailed in full in Section 7 Message Formats & Options.

WindObserver II may be configured using standard terminal communications software on a PC. This is explained in Section 8 Configuring.

## 3. FAST TRACK SET-UP

If you are in a hurry to try out the WindObserver II, are familiar with Gill equipment, and coupling to a PC using RS422, go to the following sections:

*Section 6 Installation*

*Section 7 Message Formats & Options*

*Section 8 Configuring*

After you have successfully set up the WindObserver II, we strongly advise that you then go back and read the rest of the manual to ensure that you get the best results from the WindObserver II.

## 4. SPECIFICATION

### Measurement

|            |  |
|------------|--|
| Output     | 1, 2, 4, 5, 8, 10Hz  |
| Parameters | UV, Polar, NMEA, Tunnel  |
| Units      | m/s, Knots, MPH, KPH ft/min  |
| Averaging  | Flexible 1-3600 seconds or<br>Adjustable Averaging for Road Weather applications |

### Wind Speed

|            |                      |
|------------|----------------------|
| Range      | 0 - 65m/s (0-145mph) |
| Accuracy   | ±2%@12m/s            |
| Resolution | 0.01m/s              |
| Offset     | ±0.01m/s             |

### Direction

|            |          |
|------------|----------|
| Range      | 0 - 359° |
| Accuracy   | ± 2°     |
| Resolution | 1°       |

### Sonic Temperature Output

|       |                 |
|-------|-----------------|
| Range | -40°C to + 70°C |
|-------|-----------------|

### Anemometer Status

Supplied as part of standard message

### Starting Threshold

0.01 m/s

### Dead Band Wind Direction

None

### Power Requirement

|                 |  |
|-----------------|--|
| Anemometer only | 9-30 V DC (30mA) @ 12VDC, non-analogue unit<br>9-30V DC (50mA) @12V DC, analogue unit<br>reverse voltage protected |
|-----------------|--|

### Heating - Optional

Allow 3A @ 22v to 30v (max) AC rms or DC

### Digital Output

|               |   |
|---------------|---|
| Communication | RS422, full duplex, RS485 2 wire network facility |
| Baud rates    | 1200, 2400, 4800, 9600, 19200, 38400              |
| Formats       | 8 data, odd, even or no parity, 1 stop bit        |

### Analogue Output - Optional

|                     |   |
|---------------------|---|
| Quantity            | 3 (speed, direction, status or Sonic Temperature) |
| Scale               | Multiples of ± 10m/s up to ± 70m/s                |
| Type                | ± 2.5V, 0-5V or 4-20mA                            |
| V output resistance | 60 Ohms   |
| 4-20mA loading      | 10-300 Ohms                                       |

### Dimensions

|        |               |
|--------|---------------|
| Size   | 381mm x 213mm |
| Weight | 1.5kg         |

### Materials

|                       |                     |
|-----------------------|---------------------|
| External Construction | Stainless Steel 316 |
|-----------------------|---------------------|

### Environmental

|                       |   |
|-----------------------|---|
| Moisture protection   | IP66 (NEMA4X)   |
| Operating temperature | -55°C to +70°C (heated version)   |
| Humidity              | 0% to 100% RH   |
| Precipitation         | 300mm/hr  |
| EMC                   | BS EN 60945 (Emissions)<br>BS EN 61326 (Immunity)<br>FCC CFR47 Parts 15.109 Class A |
| Icing                 | MILSTD810F Method 521.2 Procedure 1   |

### Standards

Traceable to UK national standards  
Lloyds Register Type Approved  
ABS Product Design Assessed (PDA)  
None required. (See Section 10.7 Zero Wind Check)

## 5. PRE-INSTALLATION

### 5.1. Equipment supplied

|     |  |   |
|-----|--|---|
|     | WindObserver II, 1390-PK-006   | RS422 output                                |
| or  | WindObserver II, 1390-PK-026   | RS422 output and analogue outputs           |
| or  | WindObserver II, 1390-PK-007   | RS422 output and de-icing                   |
| or  | WindObserver II, 1390-PK-027   | RS422 output, analogue outputs and de-icing |
| and | Installation kit (comprising a gasket and four Stainless Steel screws) |   |
| and | WindObserver II User Manual (this manual)                              |   |
| and | Integrity Check Chamber (ICC) 1277-00-052 (Optional)                   |   |

### 5.2. Installation requirements

**Host system** - One of the following:

- PC with an internal or external interface compatible with the RS422 output from the WindObserver II.
- Gill WindDisplay.
- Other equipment with I/O compatibility to the WindObserver II option selected.  
For example if the unit has Analogue outputs, a Data Logger, Chart Recorder, or PC fitted with an ADC card.
- Networking - Multiple WindObserver II units can be networked.

**Software** -.

- HyperTerminal or other Terminal Emulation software packages.

#### **Cable and Junction box**

To connect between the WindObserver II and the host system. The unit is supplied with a 2m or 10m flying cable, requiring a mast mounted junction box (not provided) for onward connection.

*See Section 6.5 for connection details*

The flying cable must be retained with a cable tie within 150mm of the base of the anemometer.

## **Mounting Bracket**

A mounting bracket is required (not provided) which will attach to the WindObserver II via the four tapped holes in the base of the unit. Always ensure that the gasket supplied is fitted to the base of the anemometer.

It is important that the gasket supplied forms a watertight seal on the base of the anemometer.

In the event that the mounting bracket supplied by the customer is not flat or does not form complete support for the anemometer base; the customer must fit a mounting ring as shown in Figure 2.

*See Section 6.9 for mounting details.*

## 6. INSTALLATION

**Do NOT remove the black “rubber” transducer caps. Take care not to knock the four Transducer arms. All the time the WindObserver II is not in its final location, it should be protected from damage by keeping it in the original packaging as long as possible, treating it as a delicate instrument.**

**If an Intrinsically Safe (IS) device is required, the I.S. WindObserver must be used - the WindObserver II is NOT an IS device.**

**Warranty is void if the unit case is removed.**

### 6.1. Installation Guidelines

The WindObserver II has been designed to meet and exceed the stringent standards listed in its specification. Operating in diverse environments all over the world, WindObserver II requires no calibration or adjustment whatsoever.

As with any sophisticated electronics, good engineering practice should be followed to ensure correct operation.

- Always check the installation to ensure the WindObserver II is not affected by other equipment operating locally, which may not conform to current standards, e.g. radio/radar transmitters, boat engines, generators etc.

Guidelines –

- Avoid mounting in the plane of any radar scanner – a vertical separation of at least 2m should be achieved.
- Radio transmitting antennas, the following minimum separations (all round) are suggested
  - VHF IMM – 1m
  - MF/HF – 5m
  - Satcom – 5m (avoid likely lines of sight)
- Ensure the product is correctly earthed in accordance with this manual
- Use cables recommended by Gill, keeping the length below the maximum allowed (*See Section 6.3*) Where the cables are cut and re-connected (junction boxes, plugs and sockets) the cable screen integrity must be maintained, to prevent the EMC performance being compromised.
- Earth loops should not be created – earth the system in accordance with the installation guidelines. (*See Section 6.1*)
- Ensure the power supply operates to the WindObserver II specification at all times.

Avoid turbulence caused by surrounding structures that will affect the accuracy of the WindObserver II such as trees, masts and buildings. The World Meteorological Organisation makes the following recommendation:

- The standard exposure of wind instruments over level open terrain is 10m above the ground. Open terrain is defined as an area where the distance between the sensor and any obstruction is at least 10 times the height of the obstruction.

When installing the unit degrease the unit and hold with lint free gloves to reduce the build-up of deposits.

## 6.2. Bench system test

**Note:** Prior to physically mounting the WindObserver II in its final location, we strongly recommend that a bench system test be carried out to confirm the system is configured correctly, is fully functional and electrically compatible with the selected host system and cabling (preferably utilising the final cable length). The required data format, units, output rate, and other options should also all be configured at this stage. If an Integrity Check Chamber (ICC) has been purchased refer to Section 10.7.

## 6.3. Cabling

### Cable type

A RS422 compatible cable should be used, with the number of twisted pairs matching the application. If both the (optional) Heating and Analogue outputs are utilised, then a 9 pair cable is required.

**Generic description** – Twisted pairs with drain wire, screened with aluminised tape, with an overall PVC sheath. Wire size 7/0.2mm (24 AWG)

The table shows some suitable manufacturers' references; other manufacture's equivalents can be used.

**Table 1**

| No. of Pairs | Gill ref. | Belden ref. | Batt electronics ref. | Cable Gauge |
|--------------|-----------|-------------|-----------------------|-------------|
| 2            | -         | 9729        | 91071                 | 24          |
| 3            | 026-02660 | 9730        | 91030                 | 24          |
| 4            | 026-03156 | 9728        | 91199                 | 24          |
| 6            | -         | 8778        | 91011                 | 22          |
| 9            | 026-02663 | 8774        | 91009                 | 22          |

### Cable length

The typical maximum length at 9600 baud is 1km (3200ft), using the recommended cable. If any problems of data corruption are experienced (due to, for example, a high local electrical 'noise' level), then a lower baud rate should be used. Alternatively, a thicker or higher specification cable can be tried. If a heated unit is used on longer cables than supplied, consideration should be given to powering the heater using lower gauge wire or paralleling wires to reduce volt drops.

### Cabling and junction box

The WindObserver II unit is fitted with a flying 9 pair cable attached (2m or 10m long). This must be terminated in a suitable terminal box to IP66 or better, fitted with glands to prevent moisture ingress.

The cable type from the terminal box to the host system must be as specified above. If any cable is likely to be exposed to mechanical damage, it must be enclosed in a suitable conduit or cable tray. The cable must be securely fixed with cable clamps or equivalent at regular intervals such that the WindObserver cable gland does not support the cable weight.

The gland area at the base of the WindObserver II **should not** be directly exposed to moisture, as whilst the gland is sealed when mated, the anemometer is vented to air at the base to avoid pressure build up. If an IP66 rating is essential or the unit is mounted other than 'right way up' **use the gasket** provided in the mounting kit and apply additional sealing compounds around the base. .

## 6.4. Power supplies

### [All WindObserver II units](#)

#### Sensor Supply: -

|         |   |
|---------|---|
| Voltage | 9 to 30v DC   |
| Current | 30mA Average. 50mA Max @12v dc (non-analogue unit)            |
| Current | 50mA Average, 65mA Max @ 12v dc (analogue unit 0-5v setting). |

- The WindObserver II has reverse polarity protection.

### [Wind Observer II Units with Heating](#)

#### Heater Supply: -

|         |                                |
|---------|--------------------------------|
| Voltage | 22V to 30V (max) AC RMS or DC. |
| Current | allow for 3A.                  |

- **The AC Supply must be isolated from Mains Supply.**
- The heating module requires a separate power supply.
- Heater Cable length should be minimised to avoid cable volt drops and ensure maximum voltage received at the Anemometer.
- The heating (H command) is not enabled as a default condition. If heating is required enabled then the H command must be set for H2.
- Each transducer is heated independently and will be active when ambient temperature drops below approximately +15°C each transducer will de-activate when +25°C threshold is reached.

The WindObserver II has reverse polarity protection.

## 6.5. Connections

**Important** Do NOT join any of the cores of the cable together. Joining cores could damage the unit permanently. Any cores not used should be isolated.

Do NOT connect the unit's 0V, heating -ve, analogue output 0V or digital 0V to the screen or earth.

The screens of each pair are joined together inside the anemometer - these should be joined to the cable screen(s) of any further cable run. Avoid long grounding loops. Digital 0V should be used in conjunction with RS422 TX RX lines in order to improve noise immunity. Each pair in the cable is labelled with its pair number.

**Table 2**

| Conductor colour  |        | Designation                         |
|---|--------|-------------------------------------|
| Pair 1  | green  | RS422_TXB (+)                       |
|   | black  | RS422_TXA (-)                       |
| Pair 2  | white  | RS422_RXB (+)                       |
|   | black  | RS422_RXA (-)                       |
| Pair 3  | red    | Supply V+                           |
|   | black  | Supply V-                           |
| Pair 4  | blue   | Digital 0v                          |
|   | black  | Analogue 0v                         |
| Pair 5  | yellow | Heater + * <sup>1</sup>             |
|   | black  | Heater - * <sup>1</sup>             |
| Pair 6  | brown  | Analogue Ch 3 output * <sup>2</sup> |
|   | black  | Analogue 0v * <sup>2</sup>          |
| Pair 7  | orange | Not used (isolate) * <sup>2</sup>   |
|   | black  | Not used (isolate) * <sup>2</sup>   |
| Pair 8  | white  | Analogue Ch 1 output * <sup>2</sup> |
|   | red    | Analogue Ch 2 output * <sup>2</sup> |
| Pair 9  | green  | Not used (isolate) * <sup>2</sup>   |
|   | red    | Not used (isolate) * <sup>2</sup>   |
| Screens   |        | Chassis ground                      |
| * <sup>1</sup> and * <sup>2</sup> Note may not be functional - check model number and options fitted. |        |                                     |
| * <sup>2</sup> <b>NOTE Analogue connections change on units from serial number 901001.</b>            |        |                                     |

### Earthing or grounding

To ensure correct operation, and for maximum protection against lightning, the anemometer **MUST** be correctly earthed (grounded) via its mountings. Inadequate Earthing will degrade anemometer performance, particularly in the presence of radio frequency interference.

See Fig 1 **Suggested mounting bracket and Earthing (grounding) arrangements**

The unit **MUST** be connected to an appropriate grounding point with a minimum of 6mm<sup>2</sup> copper wire, via the M5 base screws. The cable screens must be joined with any cable screen continuing from the unit's cable via a junction box. The primary earth for the anemometer must be provided via the base screws and not via the cable screens.

## **Default Settings**

The factory default settings are:

### Non - heated units

A0 B3 C1 E1 F1 G0000 J1 K1 L1 M2 NA O1 P1 T1 U1 V1 X1 Y1 Z1

### Heated units

A0 B3 C1 E1 F1 G0000 H1 J1 K1 L1 M2 NA O1 P1 T1 U1 V1 X1 Y1 Z1

**Note** that Heating (H command) is not enabled as a default condition. If heating is required enabled then the H command must be set for H2.

*See Section 8 Configuring for further details*

## Connecting to a PC with a RS422 or RS485 input

The PC requires either an internal RS422 interface card, or an external RS422/485 to RS232 converter, which will plug into the standard 9 way or 25 way RS232 serial port of the PC or host equipment.

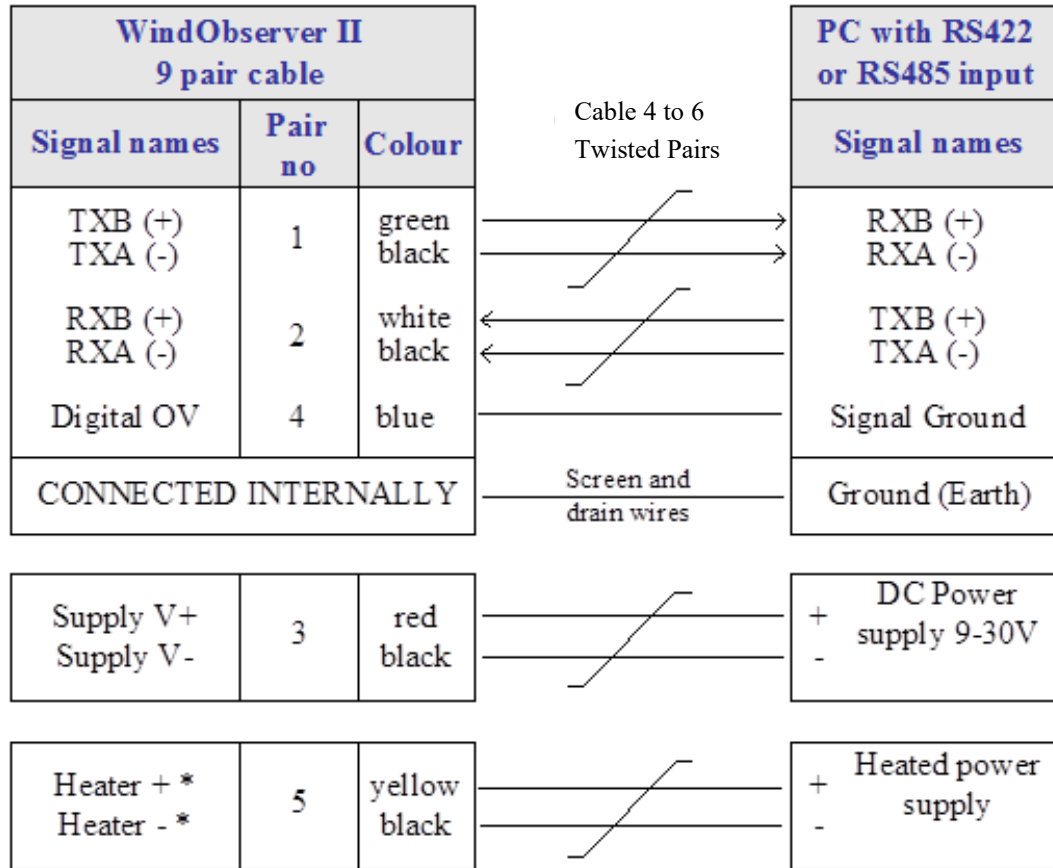

\* If unit is fitted with a heater

## Networking units

Before coupling units into a network:

- Each device must be configured with a unique Unit Identifier (letter A to Z) however in multi drop systems it could be advised to avoid using letters A-F, KMN and P as they could appear in the data string.
- Unit must be set for half duplex mode (E2 setting) see Para 7.3).
- It must be configured to a tri-state polled mode [M3](#) or [M4](#).

*See also Section 8 - Configuring*

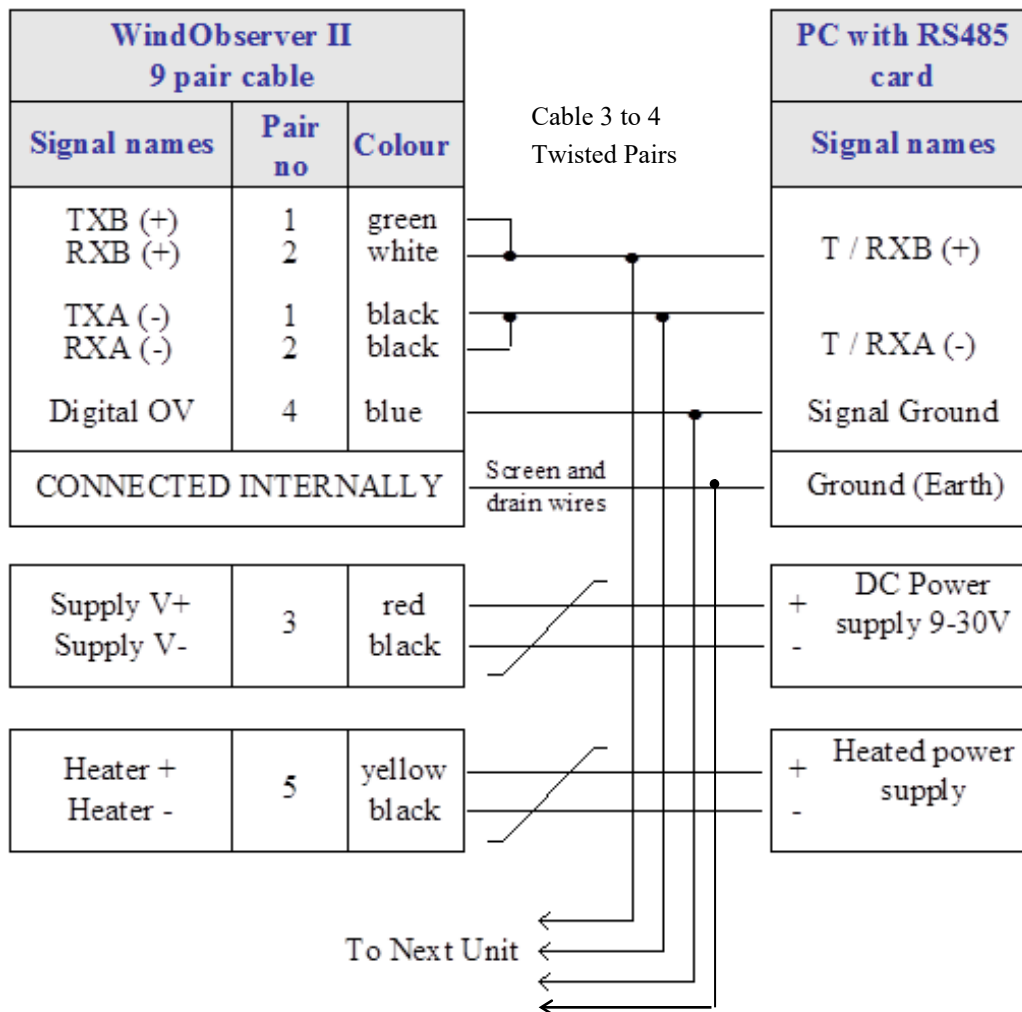

**Note:** Each unit in the network will require its own power supplies.  
Please refer to section 7.3.

### Connecting to a PCI Unit with RS422 input

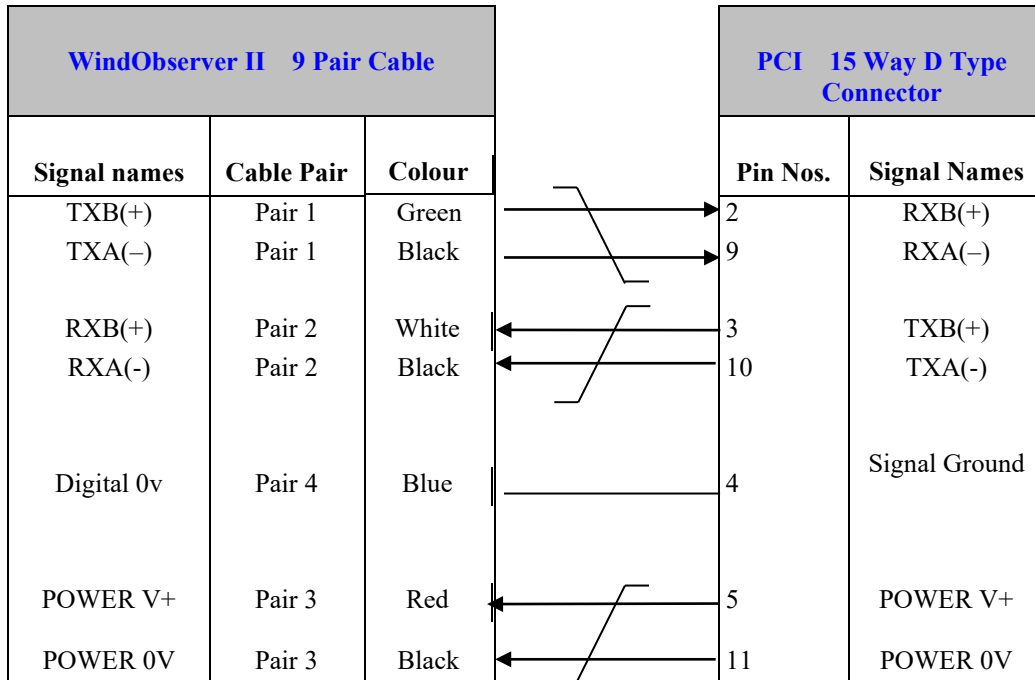

### 6.6. Indoor Power and Communications Interface (Part 1189-PK-021)

#### Environmental

The desktop PCI is intended for use in a protected environment and provides interfacing to a single anemometer. The PCI is not intended for outdoor use.

#### PCI Electrical Power Requirements

- 1) 100Vac – 120Vac, 10VA for the 115V switch position
- 2) 200 Vac – 250Vac, 10VA for the 230V switch position
- 3) 9-30Vdc, 120mA max (anemometer)  
8-15Vdc, 50mA max (interface)

3 Fuses protect the unit:

1. Externally accessible                      315mA(T) for 115/230v operation
2. Internally accessible                      500mA (T) AUX  
500mA (T) ANEM

## PCI Connector Pin and Cable assignments

### Anemometer connector – 15 way

| Pin | Designation               | (Example Plug MH Connectors MHDM15-DM15P-K) |
|-----|---------------------------|---|
| 1   | Chassis                   | (e.g. RS Components 765-9494)               |
| 2   | RS422_RXB (+)             |   |
| 3   | RS422_TXB (+)             |   |
| 4   | Digital 0V, Signal ground |   |
| 5   | Supply V+                 |   |
| 6   | Analogue output V1        |   |
| 7   | Not used                  |   |
| 8   | Analogue output V2        |   |
| 9   | RS422_RXA (-)             |   |
| 10  | RS422_TXA (-)             |   |
| 11  | Supply V-                 |   |
| 12  | Not Applicable            |   |
| 13  | Analogue 0V               |   |
| 14  | Not used                  |   |
| 15  | Analogue output V3        |   |

### Auxiliary Analogue Outputs – 9 way

| Pin | Designation  | (Example MH Connectors MHDM9-DM9S-K) |
|-----|--|--------------------------------------|
| 1   | Earth  | (e.g. RS Components 765-9488)        |
| 2   | Analogue Ground 1  |                                      |
| 3   | Analogue Ground 2  |                                      |
| 4   | Analogue Ground 3  |                                      |
| 5   | Not Applicable   |                                      |
| 6   | Analogue Output 1 (direct connection to Anemometer Connector Pin 6)  |                                      |
| 7   | Analogue Output 2 (direct connection to Anemometer Connector Pin 8)  |                                      |
| 8   | Analogue Output 3 (direct connection to Anemometer Connector Pin 15) |                                      |
| 9   | Not Applicable   |                                      |

### DC Supply – 4 way

| Pin | Designation   | (Example Connector Amphenol CO91A) |
|-----|---------------|------------------------------------|
| 1   | Interface V+  | (e.g. T3301001)                    |
| 2   | Interface V-  |                                    |
| 3   | Anemometer V- |                                    |
| 4   | Anemometer V+ |                                    |

**RS 232 Output – 9 way**

| <b>Pin</b> | <b>Designation</b> | <b>(Example Plug MH Connectors MHD9-DM9P-K)</b> |
|------------|--------------------|---|
| 1          | DCD                | (e.g. RS Components 765-9485)                   |
| 2          | RX data            |   |
| 3          | TX data            |   |
| 4          | DTR                |   |
| 5          | Signal Ground      |   |
| 6          | DSR                |   |
| 7          | RTS                |   |
| 8          | CTS                |   |
| 9          | RI                 |   |

**RS422 Network In – 9 way Skt**

| <b>Pin</b> | <b>Designation</b> | <b>(Example Plug MH Connectors MHD9-DM9P-K)</b> |
|------------|--------------------|---|
| 1          | Not connected      | (e.g. RS Components 765-9485)                   |
| 2          | Not connected      |   |
| 3          | Not connected      |   |
| 4          | RS422_RXA (-)      |   |
| 5          | Signal ground      |   |
| 6          | RS422_TXA (-)      |   |
| 7          | RS422_TXB (+)      |   |
| 8          | RS422_RXB (+)      |   |
| 9          | Chassis            |   |

**RS422 Network Out – 9 way Plg**

| <b>Pin</b> | <b>Designation</b> | <b>(Example MH Connectors MHD9-DM9S-K)</b> |
|------------|--------------------|--|
| 1          | Not connected      | (e.g. RS Components 765-9488)              |
| 2          | Not connected      |  |
| 3          | Not connected      |  |
| 4          | RS422_RXA (-)      |  |
| 5          | Signal ground      |  |
| 6          | RS422_TXA (-)      |  |
| 7          | RS422_TXB (+)      |  |
| 8          | RS422_RXB (+)      |  |
| 9          | Chassis            |  |

**PCI Operation.**

There are three Red LED's on the PCI front panel.

When the PCI box is powered the Power LED will illuminate.

When a WindObserver is connected as above to the PCI box and is set to output continuous data the PCI box RX LED will flash on/off at the WindObserver output rate thus giving a good indication that the WindObserver output is wired to the PCI box correctly and outputting RS422 data correctly.

If the PCI RS 232 connection is connected to a computer then when a terminal programme is opened and commands sent by a PC keypad or program to the PCI box its TX LED will illuminate intermittently indicating a good connection between the PC and PCI box.

## 6.7. Analogue connections

When using the analogue outputs it is advisable to use a low pass filter to remove any high frequency noise present.

The analogue signals can be susceptible to external interference if unprotected. The anemometer cable has individual screens covering each channel's signal wires. The continuing cable connected to the anemometer must be of equal or greater cross sectional area as the anemometer cable and must be individually screened or screened pairs.

Note that connections can also be made to a PC or other device as described in the preceding sections.

REFER TO SECTION 8.6 the T command selects Voltage or Current Output on Channels 1-3.

### Analogue Voltage Output Connections (5v or $\pm 2.5v$ )

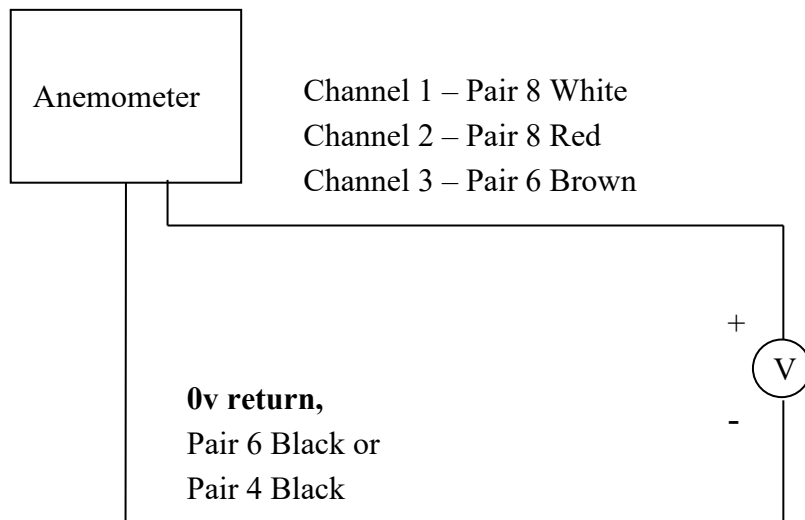

### Analogue Connections for 4-20mA output

**Important – When using the current outputs, the output loads on each channel MUST be less than 300 ohms, including cable resistance.**

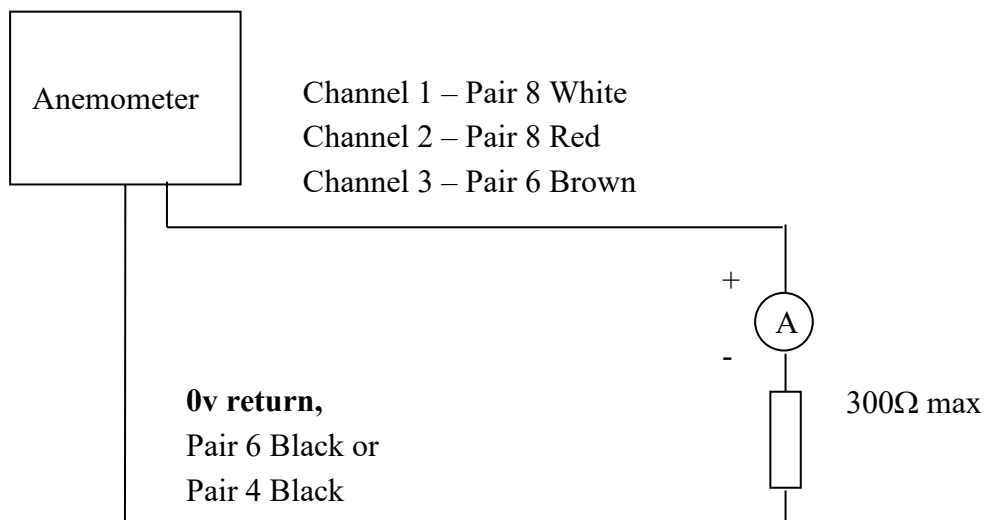

## 6.8. Using the WindObserver II with WindDisplays

### Marine WindDisplay

The WindObserver II is designed to interface with a Marine WindDisplay unit to provide a complete wind speed and direction system.

When coupled to a Gill supplied Marine WindDisplay (Fig 3), the WindObserver II must be set for NMEA (M5 setting, not default) and 4800 baud (B2 setting, not default).

In some installations NMEA, 9600 baud (B3 setting) is used and this would require re-configuring both the WindObserver and the display for 9600 baud to work.

If the WindObserver 65 is used in default CSV mode (O1) and a fault occurs then note that the WindDisplay may lock into the last valid reading. If required re-configuring the WindObserver 65 to Fixed Field output (O2) will ensure that any fault is flagged on the WindDisplay.

WindObserver II, 4800 Baud and NMEA unheated configuration settings would be:-

A0 B2 C1 E1 F1 G0000 J1 K1 L1 M5 NA O1 P1 T1 U1 V1 X1 Y1 Z1

WindObserver II, 4800 Baud and NMEA heated configuration settings would be:-

A0 B2 C1 E1 F1 G0000 H2 J1 K1 L1 M5 NA O1 P1 T1 U1 V1 X1 Y1 Z1

**NOTE:** Although the WindDisplay can show wind speed in various units, these are calculated within the WindDisplay. **The WindObserver data sent to the WindDisplay must be in metres/sec** (U1 factory default output setting).

Gill Supplied Marine Wind Display Part Numbers are:-

| Gill Display Part | Supply Voltage | Data Format | Baud Rate |
|-------------------|----------------|-------------|-----------|
| 1086-PK-083       | 220V AC        | NMEA        | 4800      |
| 1086-PK-084       | 110V AC        | NMEA        | 4800      |

After coupling the WindObserver to a WindDisplay, the Wind Speed units and the Averaging period can be selected using the WindDisplay controls.

**Fig 3 Gill Supplied Marine WindDisplay**



## Connections to a Gill Marine WindDisplay

If required the WindDisplay can provide a 15V DC supply voltage for the WindObserver sensor circuitry but cannot be used to provide a supply voltage for heater circuitry.

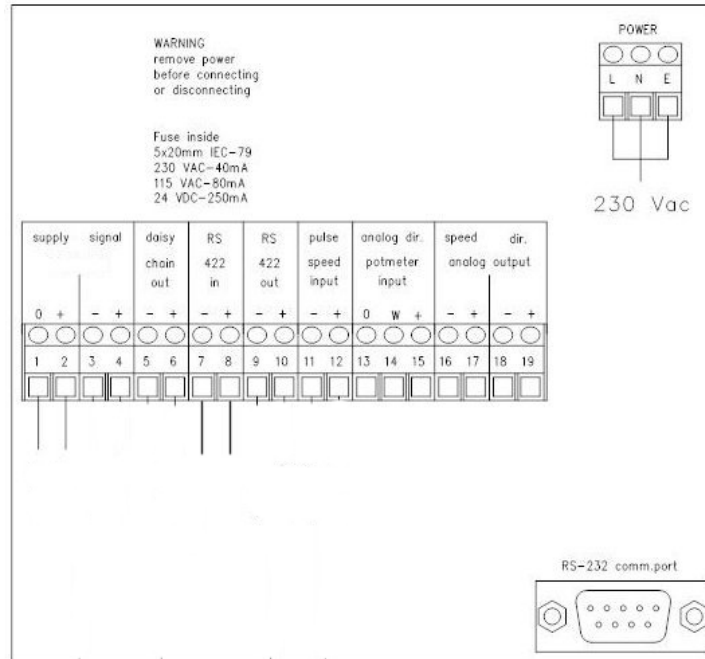

### Wiring Connections

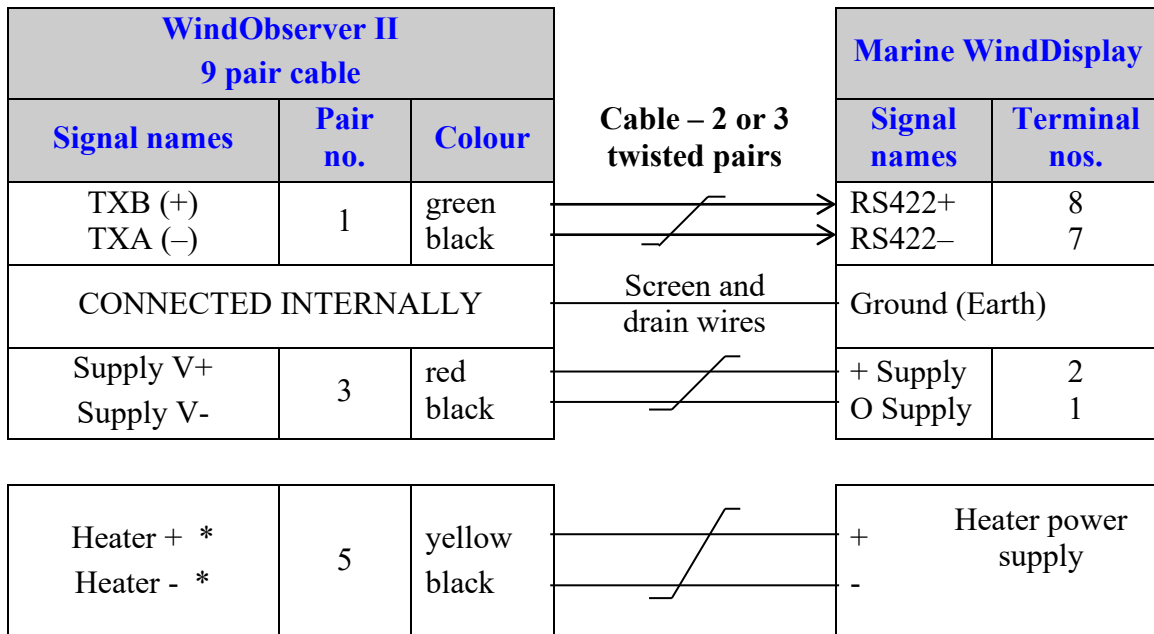

#### Notes:-

\*For Heater Power Supply Information see Section 6.4.

See Section 8, WindObserver configuration if required.

## Meteorological WindDisplay

The WindObserver II is designed to interface with a Meteorological WindDisplay unit to provide a complete wind speed and direction system.

**To interface to the Meteorological WindDisplay the WindObserver must be set for NMEA (M5) and 4800 Baud (B2) configuration settings.**

WindObserver II, 4800 Baud and NMEA unheated configuration settings would be:-

A0 B2 C1 E1 F1 G0000 J1 K1 L1 M5 NA O1 P1 T1 U1 V1 X1 Y1 Z1

WindObserver II, 4800 Baud and NMEA heated configuration settings would be:-

A0 B2 C1 E1 F1 G0000 H2 J1 K1 L1 M5 NA O1 P1 T1 U1 V1 X1 Y1 Z1

Meteorological Wind Display Part numbers are:-

| Gill Part   | Supply Voltage  | Data Format | Baud Rate |
|-------------|-----------------|-------------|-----------|
| 1086-PK-120 | 100V to 240V AC | NMEA        | 4800      |
| 1086-PK-121 | 18V to 32V DC   | NMEA        | 4800      |

**NOTE:** Although the WindDisplay can display wind speed in various units, these are calculated within the WindDisplay. **The WindObserver data coming to the WindDisplay must be in metres/sec (U1 factory default output setting).**



Meteorological WindDisplay

## Connections to a Meteorological WindDisplay.

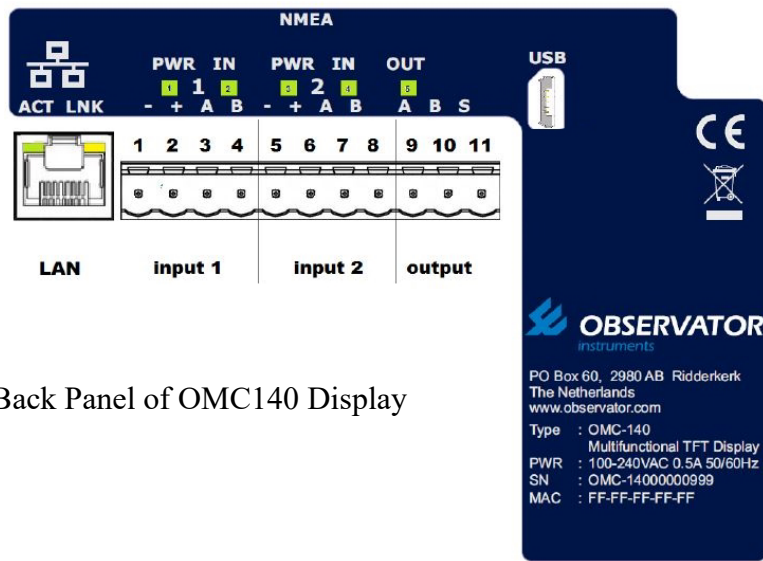

### Wiring Connections

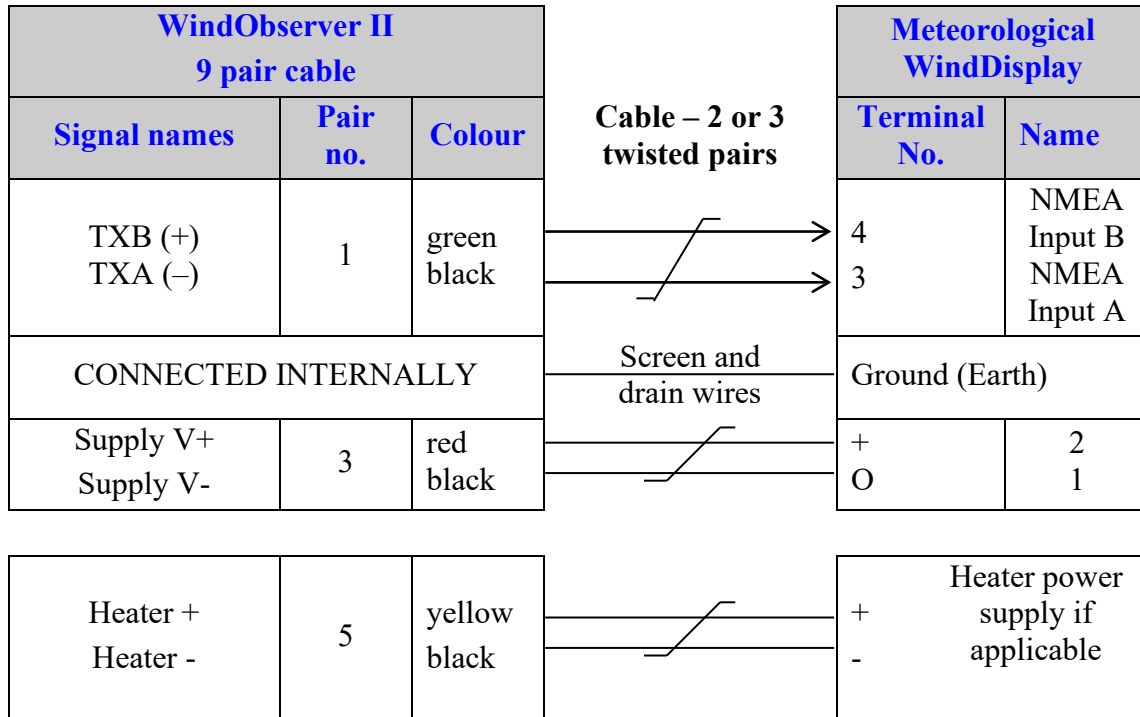

For Power Supply Information see Section 6.4.

See Section 8, WindObserver configuration if required.

## 6.9. Mechanical installation

**Do NOT remove the black “rubber” transducer caps. Take care not to knock the four Transducer arms.**

**Before installing, a bench system test is recommended.**

**All the time the WindObserver II is not in its final location, it should be protected from damage by keeping it in the original packaging as long as possible, treating it as a delicate instrument.**

**When installing the unit handle with lint free gloves and degrease the unit to reduce the build-up of deposits.**

**Do not apply clamps to the WindObserver cylinder body as this will distort the cylinder and affect sealing.**

### Location

It is important to ensure that the WindObserver II is mounted in a position clear of any structure, which may obstruct the airflow or induce turbulence.

Do NOT mount the WindObserver II in close proximity of high-powered radar or radio transmitters. A site survey may be required if there is any doubt about the strength of external electrical noise. (*See Section 6.1*)

### Orientation

Normally the WindObserver II is mounted vertically with the cable exit at the bottom.

Alternatively, the unit may be mounted in any orientation, but note that if the unit is mounted with the cable uppermost, the base gasket provided in the mounting kit **must** be used. It is advised to apply sealant around the base and cable gland area to prevent water penetration into the unit. Fit the supplied gasket if the 2 metal mounting faces are of dissimilar metals to prevent galvanic corrosion.

### Mounting bracket

A suggested mounting bracket is shown in the following figure.

It is recommended that the WindObserver II mounting bracket be manufactured from stainless steel 316, to prevent possible galvanic corrosion.

It is also recommended that the supplied gasket be always fitted to ensure IP66 rating and to prevent galvanic corrosion if the mounting bracket is not manufactured from stainless steel 316.

Stainless steel 316 fixings must be used.

**Figure 2. Suggested mounting bracket and Earthing (grounding) arrangements**

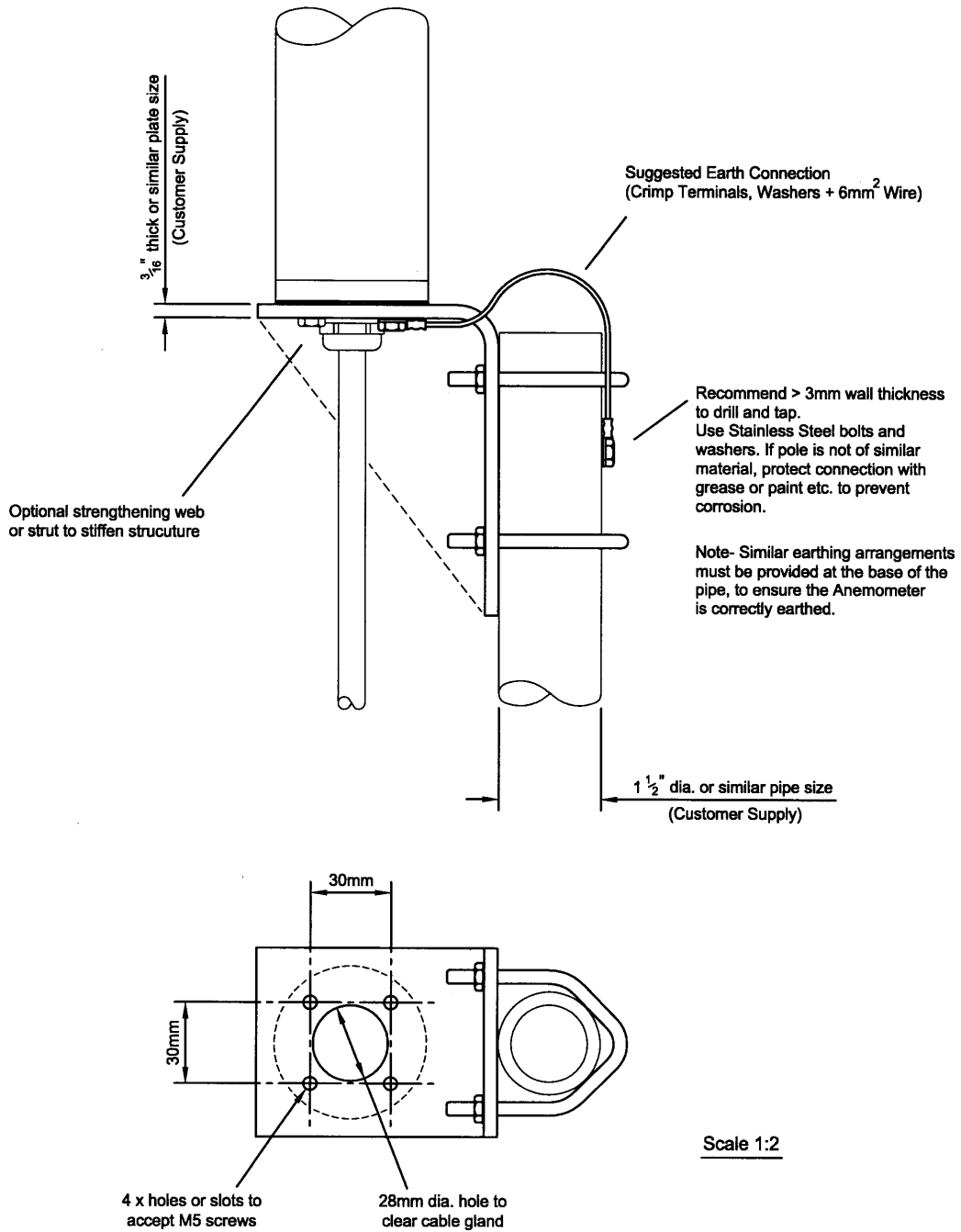

## Alignment

The anemometer should be set to point North (or to another known reference direction), using the North Spar, which can be identified from the red dot alignment indicator on the base of the instrument. See *Figure 2a*.

**Since all wind measurements are made relative to the North Spar, it is important to use only the North Spar for alignment and not the red dot located at the base of the unit.**

If the unit is used in a tunnel, (and the Tunnel format is used), the unit would normally be aligned with the N – S axis in the horizontal plane.

**Figure 2a North marker and UV polarity definition (UV format) and Mounting Ring**

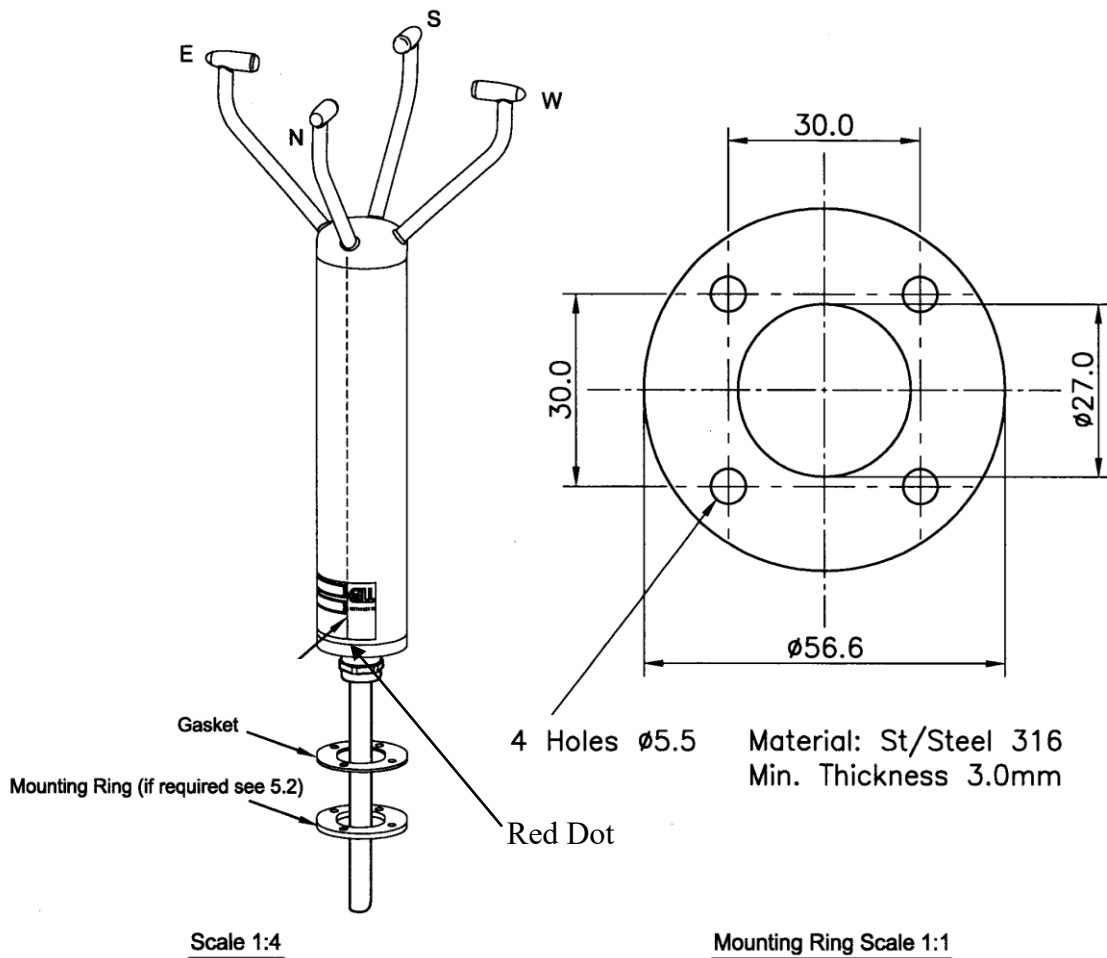

See fig.3, on page 48 for u,v definition

Figure 2b WindObserver II outline dimensions

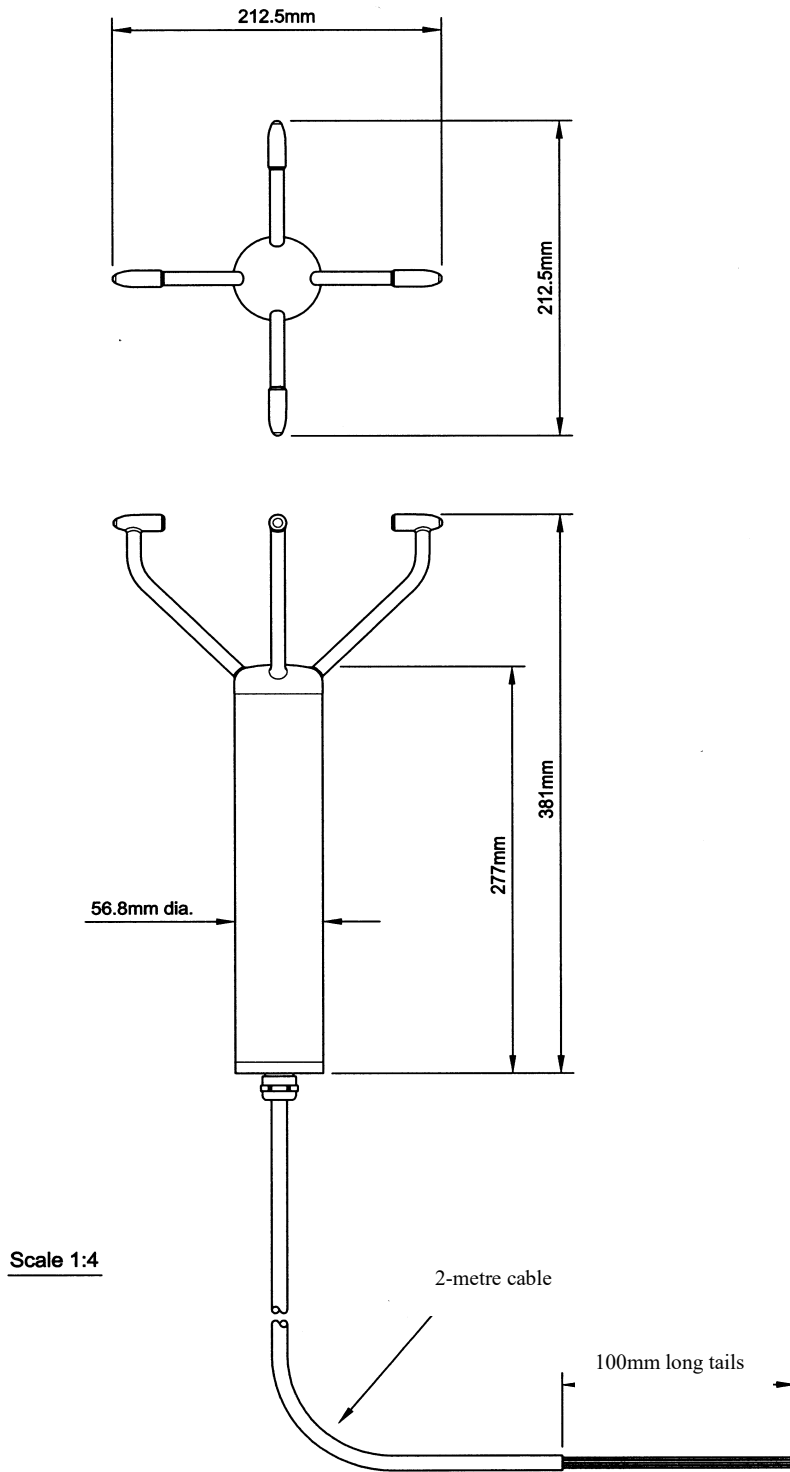

Wind Observer II 2 Axis Anemometer Overall Dimensions

## 7. MESSAGE FORMATS & OPTIONS

On first applying power to the WindObserver II, it will be in ‘Measurement Mode’, and it will output wind measurement information in one of eight formats as described below.

Setting the output format, units, other parameters, options and the communication settings are all carried out in the alternative ‘Configuration Mode’.

*See Section 8 CONFIGURING for details of how this is done.*

*The factory default settings are shown here in **bold**, and for convenience some ‘Configuration codes’ (as used to set the configuration) are shown in blue boxes.*

*For example [M3](#).*

### 7.1. Wind Speed format

The wind speed measurements can be output in one of the following formats: UV, Polar, Customer formats (NMEA and Tunnel).

### 7.2. Output formats

The UV and Polar wind speed parameters are output in either ASCII or binary.

These parameters can be transmitted continuously or polled from the user.

Polar is also available in continuous NMEA format.

#### Output Formats Table

| Output format      | Output (see Notes below) | Configuration code  |
|--------------------|--------------------------|---------------------|
| ASCII UV           | Continuous               | <a href="#">M1</a>  |
|                    | Polled                   | <a href="#">M3</a>  |
| <b>ASCII Polar</b> | <b>Continuous</b>        | <a href="#">M2</a>  |
|                    | Polled                   | <a href="#">M4</a>  |
| ASCII Tunnel       | Continuous               | <a href="#">M12</a> |
| ASCII Tunnel       | Polled                   | <a href="#">M13</a> |
| NMEA               | Continuous               | <a href="#">M5</a>  |
| Binary Tunnel      | Continuous               | <a href="#">M6</a>  |
| Binary UV short    | Continuous               | <a href="#">M7</a>  |
| Binary Polar       | Continuous               | <a href="#">M8</a>  |
| ASCII Polar        | Continuous Averaged      | <a href="#">M15</a> |
| ASCII Polar        | Polled Average           | <a href="#">M14</a> |

Notes:-

1. Continuous Output: In this mode the unit continuously outputs a burst of RS422 level data (the frequency determined by the output rate setting). After the burst of data and until the next data burst the data lines revert to a high impedance state.
2. Polled Output: In this mode the data lines are in a high impedance state until the unit is polled for data. Upon receipt of a poll command the unit outputs a burst of data at RS485 levels and then reverts to a high impedance state until the next poll command receipt.

#### Low wind speeds

Whilst the wind speed is below 0.05 metres/sec, the wind direction will not be calculated and the last known good direction figure is shown. All other output parameters will continue to update at the output rate.

## 7.3. Networking

### Gill Proprietary Network

Each anemometer connected to the network **MUST** be given a unique Unit Identifier (Letters A to Z), and set to a polled tri-state mode (UV or Polar) ([M3](#), [M4](#) or [M13](#)).

In these modes the communications transmit line is tri-state unless the anemometer is responding to a command. If used in a multi drop system then it is recommended that Unit Identifiers A, B, C, D, E, F, K, M, N and P are not used.

Configuring WindObserver II for Half Duplex Operation.

- 1) Set up Two Terminals: One for RS485 Half Duplex and the other for RS422 Full Duplex.

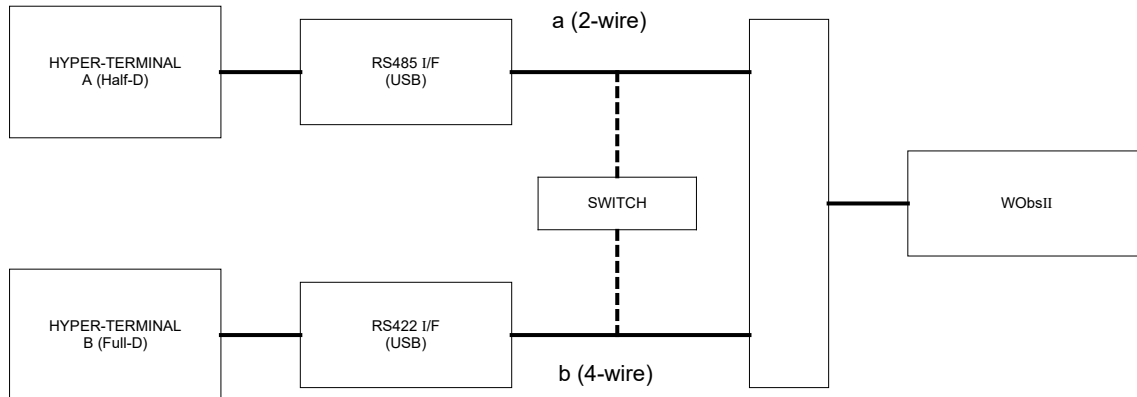

One PC (with two USB ports) can be used for both Terminals, although two may be less confusing.

Note: Power must not be disconnected from the anemometer throughout this procedure.

- 2) Assuming the unit is set for Full Duplex, connect 9-way at [b] disconnect 9-way at [a]. Set Switch to position [b] (4 wire).
- 3) On Terminal B, enter CONFIGURATION MODE. Set Half Duplex (E2). The CONFIRM> prompt will appear.
- 4) Disconnect 9-way [b] and connect 9-way [a]. Set Switch to position [a] (2 wire).
- 5) On Terminal A, type “E” <ENTER> to confirm.
- 6) The unit should now be configured in Half Duplex mode.

Configuring WindObserver II for Full Duplex Operation.

- 1) Assuming the unit is set for Half Duplex, disconnect 9-way [b] and connect 9-way [a]. Set Switch to position [a] (2 wire).
- 2) On Terminal A, type “E1” to select Full Duplex. The CONFIRM> prompt will appear.
- 3) Disconnect 9-way [a] and connect 9-way [b]. Set Switch to position [b] (4 wire).
- 4) On Terminal B type “E” <ENTER> to confirm.

## 7.4. Units

The wind speed can be set to any of the following units:

| Unit                | Abbreviation |
|---------------------|--------------|
| Metres per sec      | m/s          |
| Knots               | knots        |
| Miles per hour      | MPH          |
| Kilometres per hour | kph          |
| Feet per minute     | fpm          |

## 7.5. Output rate

The output frequency can be set between 1 and 10 per second. The wind speed is sampled every 25ms, each axis being sampled sequentially. The following Table lists the possible outputs per second and the corresponding number of averaged samples. A 25ms sample period is used to process and output the results.

| Outputs per Second | Sample Average |
|--------------------|----------------|
| 1                  | 39             |
| 2                  | 19             |
| 4                  | 9              |
| 5                  | 7              |
| 8                  | 4              |
| 10                 | 3              |

## 7.6. Averaging (Digital Data)

There are two digital averaging options:-

### 8.6.1 G Command Averaging.

Using the G Command in association with modes other than M14, M15 and polled modes.

The Averaging Period can be set from zero to 3600 secs. (1 hour). The default setting is zero. When averaging is enabled, data is output at a rate determined by the averaging period. The data is an average of valid data collected during the averaging period.

If G is set to zero then averaging settings will be disabled.

For instance if the unit is set for G0025 then every 25 seconds there will be a single result output that provides the average of the wind direction and magnitude data over the last 25 seconds.

A,219,000.78,M,60,□0D

A,202,000.79,M,60,□06

A,207,001.22,M,60,□0C

A,220,000.48,M,60,□04

## 7.6.2 Modes 14 and 15 Road Weather Averaging (RWA).

The averaging is implemented with reference to the following standard:

- Guide to Meteorological Instruments and Methods of Observation – World Meteorological Organization WMO-No8 seventh edition 2008 ISBN 978-92-63-10008-S

The direction and magnitude outputs are derived from the vector sum of U and V over the RWALONG averaging period (default 10 minutes in P1).

The gust output is derived from the vector sum of U and V over 3 readings (3 seconds in P1), and the max gust is the maximum of the gust value over the RWASHORT period (default 60 seconds in P1). The max gust value is reset to zero at the end of each RWASHORT period.

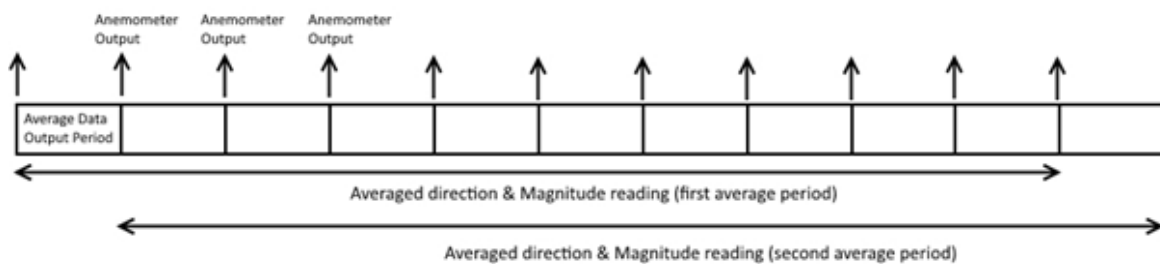

**RWA Default settings** are:-

**P (Output rate Hz)** = 1  
**RWASHORT** = 60  
**RWALONG** = 10

Therefore:

**Anemometer output period** =  $60/1 = 60$  seconds (the WindObserver will output a reading every 60 seconds).

**Averaged direction and magnitude reading** =  $10 \times 60 = 600$  seconds (this is the time the readings will be averaged over).

When the average building period has been completed, the average reported thereafter will be a rolling average derived from the last averaged direction and magnitude time period.

### Mode 15 – Averaging Data in Continuous mode.

Averaged Digital Data Output comprises of.

<Start of String>, Unit Identifier, Mode, Averaged Direction, Averaged Magnitude, units, Maximum Gust Direction, Maximum Gust Magnitude, Status, <End of String>, checksum.

e.g.

**0A,M15,293,000.03,M,338,000.05,51,¶47**

(status code 51 shows measurement average building, non-heat enabled units only).

**0A,M15,198,000.04,M,088,000.39,00,¶4B**

(status code 00 code shows measurement average building period complete and normal operation, non-heat enabled units only).

Principle set up commands associated with this averaging mode are:-

Px:- Measurement Rate, (P1) this command sets the underlying measurement rate 1Hz.

RWASHORT xx: - Short Term Number, where xx is a number from 10 to 60.

RWALONG xx: - Long Term Number, where xx is a number from 1 to 10.

The Averaged Data Output period in seconds is:-

$$\frac{\text{RWASHORT Number}}{\text{Measurement Rate (P Setting Hz value)}}$$

Therefore with the RWASHORT number set for 60 (default) and P command set for 1Hz (P1 default) the unit will output a rolling averaged reading every 60 seconds.

The Averaged Direction and Magnitude reading is based on:-

$$\text{RWALONG Number} * \text{Averaged Data Output period.}$$

Therefore if the RWALONG number is 10 (default) and Averaged Data Output Period is 60 seconds, then the rolling averaged Direction and Magnitude data is calculated over rolling 600 readings.

```

0A,M15,293,000.03,M,338,000.05,51,▼47
0A,M15,301,000.03,M,304,000.04,51,▼43
0A,M15,299,000.03,M,285,000.02,51,▼4D
0A,M15,303,000.02,M,336,000.02,51,▼47
0A,M15,291,000.03,M,200,000.64,51,▼48
0A,M15,291,000.02,M,301,000.03,51,▼48
0A,M15,243,000.04,M,172,001.52,51,▼42
0A,M15,236,000.03,M,090,000.08,51,▼44
0A,M15,243,000.03,M,099,000.09,51,▼4E
0A,M15,198,000.04,M,088,000.39,00,▼4B
0A,M15,180,000.04,M,099,000.09,00,▼41
0A,M15,180,000.03,M,345,000.03,00,▼4E

```

The Maximum Gust Direction is the direction of the maximum gust measured over the short term output period. Gust is generated from a rolling 3s average of the short term output period, and reset at the end of short term output period.

The maximum Gust Magnitude is the magnitude of the maximum gust measured over the short term output period. Gust is generated from a rolling 3s average of the short term output period, and reset at the end of short term output period.

#### Notes:-

Non Heat Enabled Units - Whenever the unit is powered up then until the unit has reached its minimum long term averaging interval the status code will read 51 (Measurement Average Building).

Heat Enabled Units - On units where heat is enabled Code 51 will not be output during the measurement average building period, therefore allow for this period on power up before taking readings to be fully averaged (maximum period of 10 minutes).

The G Command setting has no effect on Mode 14 and Mode 15 Settings.

---

**Mode 14 – Averaging Polled Mode**

See Mode 15 for data output format and command explanations.

For ease of use before changing to this Mode set all other WindObserver parameters first including:-

Px:- Measurement Rate, (P1) this command sets the underlying measurement rate of 1Hz.

RWASHORT xx: - Short Term Number, where xx is a number from 10 to 60.

RWALONG xx: - Long Term Number, where xx is a number from 1 to 10.

Once set for Mode 14, to Poll for averaged data use the ? command followed by the unit designator A (default setting, ensure capitol letter used).

The polled mode commands available in this mode are:

| Description                          | Command | WindObserver response     |
|--------------------------------------|---------|---------------------------|
| Enable Polled Mode                   | ?       | (None)                    |
| WindObserver Unit Identifier (N)     | A.....Z | Output generated          |
| Disable Polled mode                  | !       | (None)                    |
| Request WindObserver Unit Identifier | &       | A ..... Z (as configured) |
| Enter Configuration mode             | *<N>    | CONFIGURATION MODE        |

Where <N> is the unit identifier, if used in a multi-drop system then it is recommended that ID's A to F and KMNP are not used as these characters can be present in the data string.

It is suggested that in polled mode the following sequence is used for every poll for information.

? Ensures that the Sensor is enabled to cover the event that a power down has occurred.

A-Z Appropriate unit identifier (capitol letter) sent to retrieve a line of data.

! Sent to disable poll mode and reduce possibility of erroneous poll generation.

When polled with the default Mode 14 factory setting the WindObserver (set for default 1Hz output) will output the last valid 10 minute wind speed and direction average, updated every minute along with last valid 1 minute Gust magnitude.

## Notes

### Non Heat Enabled Units.

If the unit is powered up and polled before the unit has reached its minimum averaging interval the status code will read 51 (Measurement Average Building, non-heat enabled units only).

### Heat Enabled Units.

On units where heat is enabled Code 51 will not be output if polled during the measurement average building period, therefore allow for this period on power up before taking readings to be fully averaged (maximum period of 10 minutes).

```

0A,M15,293,000.03,M,338,000.05,51,♥47
0A,M15,301,000.03,M,304,000.04,51,♥43
0A,M15,299,000.03,M,285,000.02,51,♥4D
0A,M15,303,000.02,M,336,000.02,51,♥47
0A,M15,291,000.03,M,200,000.64,51,♥48
0A,M15,291,000.02,M,301,000.03,51,♥48
0A,M15,243,000.04,M,172,001.52,51,♥42
0A,M15,236,000.03,M,090,000.08,51,♥44
0A,M15,243,000.03,M,099,000.09,51,♥4E
0A,M15,198,000.04,M,088,000.39,00,♥4B
0A,M15,180,000.04,M,099,000.09,00,♥41
0A,M15,180,000.03,M,345,000.03,00,♥4E

```

## 7.7. Options

### Speed of Sound (SOS) and Temperature

Either or both of these parameters can be selected or disabled

Note that neither of these parameters is available in Tunnel or NMEA formats.

SOS is useful for calculating air temperature with a rapid response. Sonic temperature is derived from the SOS, based on an assumption of the composition of the atmosphere.

Humidity will affect the result.

True temperature can be calculated by:

$$T = T_s \frac{1}{1+0.32 e/p}$$

Where T = True temperature (Kelvin)

Ts = Sonic temperature

e = Vapour pressure of water in air

p = absolute pressure of water in air

### Heating (If fitted)

Heating is autonomous and requires no set-up once activated.

### 45° Offset

If required, the U axis can be offset +45° to the transducer axis.

### Vertical Output Padding

A dummy W vector is inserted to provide compatibility with any WindMaster that may be in a network.

## 7.8. ASCII message format (UV, Polar and Tunnel)

### ASCII UV format

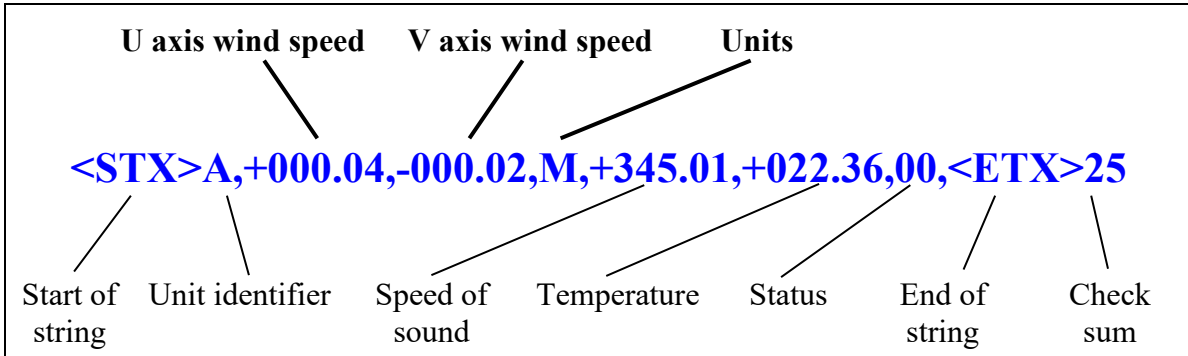

Where

**U axis wind speed**      In increments of 0.01 units ( $\pm$ UUU.UU)

**V axis wind speed**      In increments of 0.01 units ( $\pm$ VVV.VV)

| <b>Units</b> | <b>Value</b> | <b>Units</b>              |
|--------------|--------------|---------------------------|
|              | M            | Metres per second (m/s)   |
|              | N            | Knots (knots)             |
|              | P            | Miles per hour (MPH)      |
|              | K            | Kilometres per hour (kph) |
|              | F            | Feet per minute (fpm)     |

**Start of string**      ASCII value 2

**Unit identifier**      Letter A – Z (**default A**)

**Speed of sound**      In metres per second (if enabled)

**Temperature**      Sonic temperature in degrees C (if enabled)

| <b>Status</b> | <b>Value</b>    | <b>Status</b>                                    |
|---------------|-----------------|--|
|               | 0               | OK   |
|               | 60              | Heating enabled and OK if enabled                |
|               | Any other value | Warning or fault condition<br>- see Section 10.6 |

**End of string**      ASCII value 3

**Check sum**      Exclusive OR of all characters between Start of String and End of String reported as ASCII hex.

## ASCII Polar format

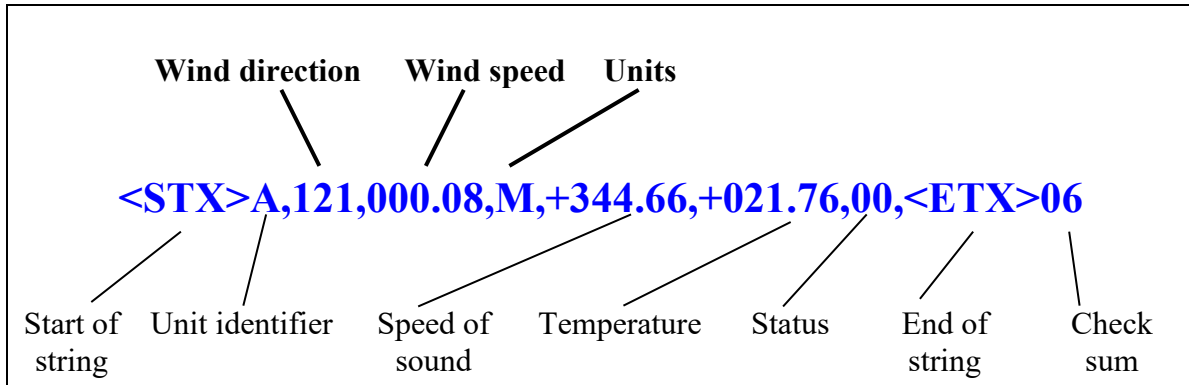

Where

**Wind direction**                      In degrees relative to N (DDD)  
**Wind speed**                              In increments of 0.01 units ( $\pm$ MMM.MM)

All other parameters                  *See Section 7.8 ASCII UV format*

## ASCII Polled (UV and Polar)

When in the Polled mode, an output is only generated when the host system sends a Poll signal to the WindObserver consisting of the WindObserver Unit Identifier – that is, the relevant letter A – Z.

The output formats are otherwise as described above.

The commands available in this mode are:

| Description                          | Command   | WindObserver response       |
|--------------------------------------|-----------|-----------------------------|
| WindObserver Unit Identifier         | A ..... Z | Wind speed output generated |
| Enable Polled mode                   | ?         | (None)                      |
| Disable Polled mode                  | !         | (None)                      |
| Request WindObserver Unit Identifier | &         | A ..... Z (as configured)   |
| Enter Configuration mode             | *<N>      | CONFIGURATION MODE          |

Where <N> is the unit identifier, if used in a multi-drop system then it is recommended that ID's A to F and KMNP are not used as these characters can be present in the data string.

It is suggested that in polled mode the following sequence is used for every poll for information.

?        Ensures that the Sensor is enabled to cover the event that a power down has occurred.

A-Z     Appropriate unit identifier sent to retrieve a line of data.

!        Sent to disable poll mode and reduce possibility of erroneous poll generation.

When in polled mode the system will respond to the data command within 30mS with the last valid data sample as calculated by the Output rate (P Mode Setting).

If the unit is powered down after use or upon switch on then allow 3 seconds from switch on before sending poll commands.

## ASCII format – Tunnel Mode

In this mode, the output is given as signed (i.e. positive or negative) speeds along the ‘U’ (= South – North) axis.

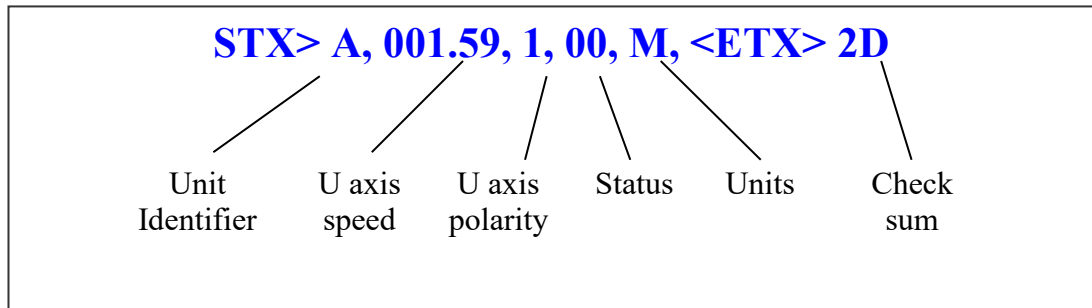

Where:

<STX> = Start of string character (ASCII value 2)  
 WindObserver unit identifier = Letter (A to Z)  
 U axis = U axis Wind Speed  
 U axis = U axis Wind Direction Polarity  
 where 0 (–U vector) is a wind from the North direction or 1 (+U vector) is a wind from the South direction.

All other parameters    *See Section 7.8 ASCII UV format*

## 7.9. Binary message format (UV, Polar and Tunnel)

### Binary UV format

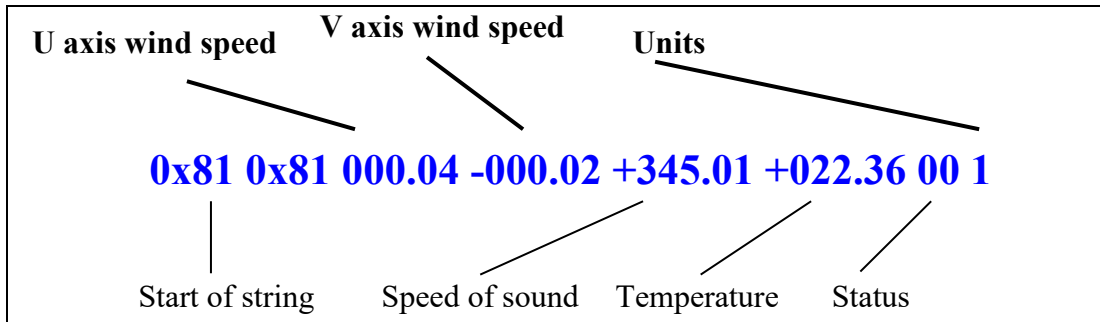

Where

**U axis wind speed**      In increments of 0.01 units ( $\pm$ UUU.UU)  
**V axis wind speed**      In increments of 0.01 units ( $\pm$ VVV.VV)

| Units | Value | Units                     |
|-------|-------|---------------------------|
|       | 1     | Metres per second (m/s)   |
|       | 2     | Knots (knots)             |
|       | 3     | Miles per hour (MPH)      |
|       | 4     | Kilometres per hour (kph) |
|       | 5     | Feet per minute (fpm)     |

**Start of string**  
**Speed of sound**      In metres per second (if enabled)  
**Temperature**      Sonic temperature in degrees C (two's complement signed) (if enabled)

| Status | Value           | Status   |
|--------|-----------------|--|
|        | 0               | OK   |
|        | 60              | Heating enabled and OK                           |
|        | Any other value | Warning or fault condition<br>- see Section 10.6 |

### Binary Polar format

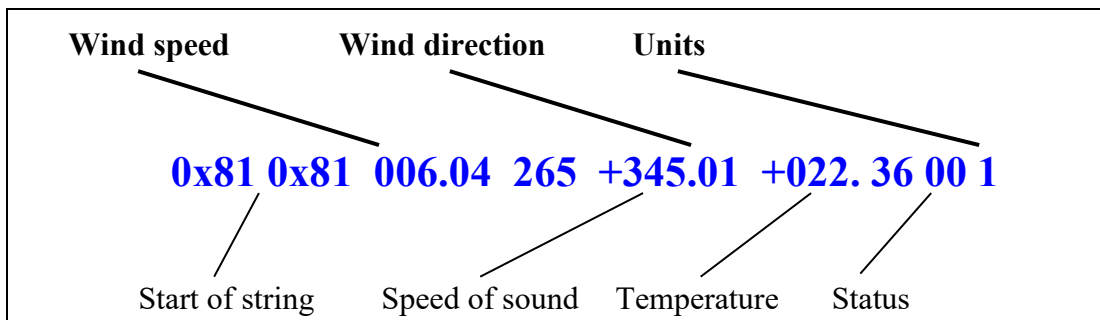

Where

**Wind direction**      In degrees relative to N (DDD)  
**Wind speed**      In increments of 0.01 units ( $\pm$ MMM.MM)  
 All other parameters      See Section 7.9 *Binary UV format*

**Binary Tunnel format**

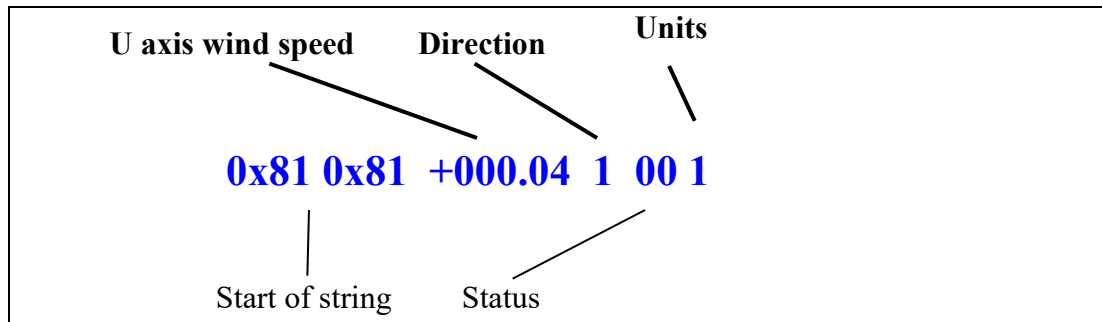

|                                 |  |                 |
|---------------------------------|--|-----------------|
| <b>U axis Wind speed</b>        | In increments of 0.01 units ( $\pm$ MMM.MM)    |                 |
| <b>Direction</b> (along U axis) | <b>Value</b>                                   | <b>Polarity</b> |
|                                 | 1  | +U              |
|                                 | 0  | -U              |
| Other parameters                | <i>See Section 7.9 <b>Binary UV format</b></i> |                 |

## 7.10. NMEA Format

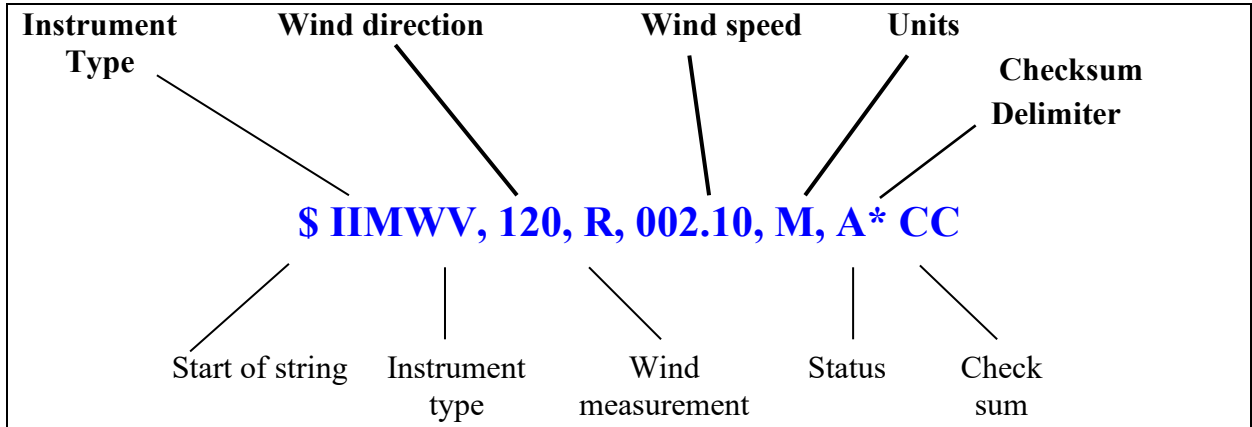

Where

|                         |  |                              |
|-------------------------|--|------------------------------|
| <b>Wind direction</b>   | In degrees relative to N (DDD)   |                              |
| <b>Wind speed</b>       | In increments of 0.01 units ( $\pm$ MMM.MM)                                |                              |
| <b>Units</b>            | M  | Metres per second (m/s)      |
|                         | N  | Knots (knots)                |
|                         | P  | Miles per hour (MPH)         |
|                         | K  | Kilometres per hour (kph)    |
|                         | F  | <b>Feet per minute (fpm)</b> |
| <b>Start of string</b>  | \$   |                              |
| <b>Instrument Type</b>  | IIMWV  |                              |
| <b>Wind measurement</b> | R  | Relative wind measurement    |
| <b>Status</b>           | A  | Acceptable measurement       |
|                         | V  | Void measurement             |
| <b>Check sum</b>        | Exclusive OR of all characters between '\$' and '*' reported as ASCII hex. |                              |

A typical WindObserver II configuration suitable for NMEA would be:

B2, E1, F1, G0, K1, L1, M5, O1, P1, U1.

Consult specification NMEA 0183 version 3 (available on the web) [www.nmea.org](http://www.nmea.org) for complete interface details.

## 7.11. Averaging Format (Modes 14 and 15)

See also Para 7.6.2.

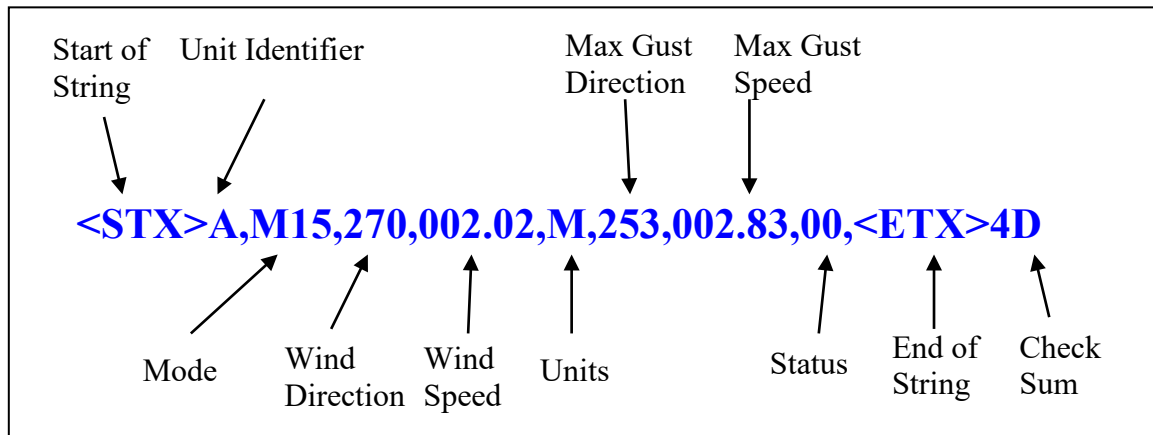

|                           |   |  |
|---------------------------|---|--|
| <b>Start of string</b>    | ASCII value 2   |  |
| <b>Unit identifier</b>    | Letter A – Z ( <b>default A</b> )   |  |
| <b>Mode</b>               | M14   | Polled Averaging   |
|                           | M15   | Continuous Output Averaging  |
| <b>Wind Direction</b>     |   | In degrees relative to North (DDD) settable average of direction in degrees.   |
| <b>Wind Speed</b>         |   | In increments of 0.01 units ( $\pm$ MMM.MM), settable average of speed in m/s. |
| <b>Units</b>              | M   | Metres per Second  |
|                           | N   | Knots  |
|                           | P   | Miles per Hour   |
|                           | K   | Kilometres per Hour  |
|                           | F   | Feet per Minute  |
| <b>Max Direction Gust</b> |   | In degrees relative to North (DDD)   |
| <b>Max Gust Speed</b>     |   | In increments of 0.01 units ( $\pm$ MMM.MM)                                    |
| <b>Status</b>             | <b>Value</b>  | <b>Status</b>  |
|                           | 00  | OK   |
|                           | 60  | Heating enabled and OK if enabled  |
|                           | 51  | Means that the averaging is incomplete (non-heat enabled units only).          |
|                           | Any other value   | Warning or fault condition<br>- see Section 10.65                              |
| <b>End of string</b>      | ASCII value 3   |  |
| <b>Check sum</b>          | Exclusive OR of all characters between Start of String and End of String reported as ASCII hex. |  |

## 7.12. Analogue outputs and options

*Analogue outputs are available as an option on the WindObserver II.*

*See Section 6.7 for connection details, and Section 8.1 for configuring the analogue outputs.*

### Output modes

There are three analogue output channels which can be configured as either voltage (0 to 5v, or  $\pm 2.5v$ ), or current outputs (4 to 20mA). They are available simultaneously with the digital outputs.

### Channel outputs

The signals on the Channel outputs 1 and 2 are dependent on the Output format chosen. The signal on Channel 3 can be configured for either Status or Temperature.

| Output format                         | Channel 1 | Channel 2   | Channel 3             |
|---------------------------------------|-----------|-------------|-----------------------|
| UV (M1, M3, or M7 (Binary))           | U         | V           | Status or Temperature |
| <b>Polar</b> (M2, M4, or M8 (Binary)) | Magnitude | Direction   |                       |
| NMEA (M5)                             | Magnitude | Direction   |                       |
| Binary Tunnel (M6)                    | U Speed   | U direction | Status or Temperature |
| Tunnel (M12)                          | U Speed   | U Direction |                       |
| Tunnel (M13)                          | U Speed   | U Direction |                       |
| Polar (M14, M15)                      | Magnitude | Direction   | Status or Temperature |

### Status

If channel 3 is configured for Status, the output will be 0v (or 4mA) if the unit is in an OK condition. In a fault condition, error code 01, 02, or 04, the output will be +5v (or 0mA).

*See Section 10.6 for the list of Error Codes.*

### Temperature

If channel 3 is configured for Temperature, it reports the temperature if it is between  $-40$  and  $+70^{\circ}\text{C}$ , scaled from +0.7V to +5V (6.25mA to 20mA). Temperatures outside this range are reported as errors by setting the output to 0V (4mA).

### Tunnel mode

In Tunnel mode, Channel 1 represents the Wind Speed along the U Axis, Channel 2 gives the direction of the wind along the U axis, where a  $-U$  vector (=wind from the 'N' direction) is represented by 0v (or 4mA), and a  $+U$  vector (=wind from the 'S' direction) by 5v (or 20mA).

### Scaling

All analogue outputs are in m/s irrespective of the digital units of measurement setting and can be scaled to have a full-scale deflection of  $\pm 10$  to  $\pm 70$  units using the Z command.

In Polar mode the  $\pm$  sign should be ignored. Only the + sign is effective.

In all cases zero Wind Speed is represented by 0V or 4mA.

### Averaging

Analogue Outputs are not averaged when using the G command.

Analogue Outputs are averaged in Modes M14 and M15 (but no Gust Output).

### Polar mode direction wraparound

The Wind Direction in Polar mode can be configured for either Standard (0 - 359°) or **Wraparound (0 - 539°)** options. If the Standard mode is used with a chart recorder, large swings of the recorder pen will be experienced each time the wind direction passes between 0 and 359°. Using the Wraparound mode, when the wind first changes from 0° to 359°, there will be a step change on the output, but after this first time the output will change smoothly each time the wind passes through 360°. (Similarly, the first time the wind veers from 539° to 180°, there will be a step change, after which the output will change smoothly).

| Wind direction (degrees) | Voltage output (V) |            | Current output (mA) |            |
|--------------------------|--------------------|------------|---------------------|------------|
|                          | Standard           | Wraparound | Standard            | Wraparound |
| 0                        | 0                  | 0          | 4.00                | 4.00       |
| 180                      | 2.5                | 1.67       | 12.00               | 9.33       |
| 360                      | 5.0                | 3.33       | 20.00               | 14.67      |
| 540                      | N/a                | 5.0        | N/a                 | 20.00      |

### Low wind speeds

Whilst the wind speed is below 0.05 metres/sec, the wind direction will not be calculated, all other output parameters will continue to update at the output rate.

The following Table shows Channel 1, 2 and 3 outputs with Polar Continuous, 4-20mA current outputs under various operating conditions.

| Condition  | Channel 1 (Wind Speed)                               | Channel 2 (Wind Direction)  | Channel 3 (4-20mA Status)        | Channel 3 (0-5v Status)         | Channel 3 (±2.5v Status)           |
|--|--|---|----------------------------------|---------------------------------|------------------------------------|
| Wind Speed, Greater Than 0.05m/s                         | Variable 4 to 20mA (value depends on Output scaling) | Variable 4 to 20mA (Value depends on Output scaling)                              | 4mA (Unit functioning correctly) | 0v (Unit functioning correctly) | -2.5v (Unit functioning correctly) |
| Wind Speed, Less Than 0.05m/s                            | Variable close to 4mA.                               | Outputs last known good/valid current reading until wind increases above 0.05m/s. | 4mA (Unit functioning correctly) | 0v (Unit functioning correctly) | -2.5v (Unit functioning correctly) |
| Any Wind Speed with Failure Codes Output 01, 02, 04 etc. | Fixed 4mA until fault clears.                        | Outputs last known good/valid current reading until fault clears.                 | 0mA (Failure code present)       | 5v (Failure code present)       | +2.5v (Failure code present)       |

### Cables.

If using 4-20mA outputs then cable length is limited to the resistance of the connecting cable (to and from the load) plus the load resistance which all together must be less than 300 ohms.

If using 0-5v output then consider volt drops on the cable that might impact on 0v and 5v readings. A 4-20mA system will be more noise immune and capable of longer cable runs.

## 8. CONFIGURING

Use a terminal emulator such as HyperTerminal (or Tera Term or Putty).

Alternatively it is possible to use Gill Wind Software as a Terminal program only (Wizard and Sync Comms not applicable). Wind will run on PC's up to and including Windows 10 and can be downloaded from:-<http://www.gillinstruments/main/software.html>.

### 8.1. Configuring using HyperTerminal

**Note** – Other terminal emulators are configured in a very similar way.

1. Decide on an available Com port that you want to use (Usually Com1).
2. Run Hypertrm.exe.
3. Create a New Connection (File → New Connection)
4. Enter a **Name** (eg WindObserver II) .
5. Change '**Connect Using**' to 'Direct to Com 1' (or other Com port as required)
6. Adjust the Port settings to match WindObserver settings. WindObserver default settings are :

**Bits per second** 9600

**Data bits** 8

**Parity** None

**Stop bits** 1

**Flow Control** (Handshaking) None

Click on OK and data similar to the following example will scroll on screen at the output rate:

©A, 229, 002.74, M, 00, ♥06

### 8.2. Entering Configuration mode

#### From Continuous mode

Type \*

#### From Polled mode

Type \*N - where N is the Unit Identifier.

*Note - the Unit Identifier must be entered as upper-case*

The WindObserver II responds with a CONFIGURATION MODE message, stops reporting wind measurements, and waits for a command (as detailed below).

### 8.3. Returning to Measurement mode

Type Q and press ENTER

If in **Continuous** mode, the anemometer responds with wind measurements immediately, continuing at the selected Sampling rate.

If in **Polled** mode,

- ? Enables poll
- N Polls anemometer (where N is the Unit identifier entered as upper-case)  
The anemometer replies with a single set of wind measurements
- & Anemometer replies with Unit identifier
- ! Disables poll

Note:- If the unit is in Polled Mode it is always best to interrogate the unit for data with a ? before the poll identifier to cater for the event that the power has been switched off or power interrupted.

If used in a multi drop system then it is recommended that Unit Identifiers A, B, C, D, E, F, K, M, N and P are not used.

## 8.4. Checking the configuration

We strongly recommend that, as a standard procedure, you use this command (D3) prior to, and after, changing any settings. It shows the current settings for all the alterable settings. We suggest you note down your settings, so that you can easily return to them.

Type \* Enters Configuration Mode (from Continuous mode)

Or Type \*N Enters Configuration Mode (from Polled mode)

Type D3 and press ENTER The WindObserver II responds with the current configuration settings.

The factory default settings for a heated unit are: -

A0 B3 C1 E1 F1 G0000 H1 J1 K1 L1 M2 NA O1 P1 T1 U1 V1 X1 Y1 Z1

How to change these settings is explained in the following sections.

To return to Measurement mode Type Q and press ENTER

## 8.5. Changing settings

To change a setting, first go into Configuration mode and then refer to the sections below. Enter the Configuration code of the new setting required, followed by ENTER.

If successful, the new setting will be echoed back as a message by the WindObserver II.

For example, to change the message format to NMEA, Type M5 and press ENTER.

The WindObserver II will reply with M5. When the unit is returned to the Measurement mode Type Q and press ENTER, it will be in NMEA format.

Note: The factory-set (default) settings are shown in **bold** in the following sections.

## 8.6. Configuration Settings

### Ax - Speed of Sound (SOS) and Temperature

| Setting                          | Configuration code |
|----------------------------------|--------------------|
| <b>Disable both</b>              | <b>A0</b>          |
| Report SOS                       | A1                 |
| Report Sonic temperature         | A2                 |
| Report SOS and Sonic temperature | A3                 |

Note that neither of these parameters is available in Tunnel or NMEA formats.

### BX - Baud Rate

| Setting     | Configuration code |
|-------------|--------------------|
| 2400        | B1                 |
| 4800        | B2                 |
| <b>9600</b> | <b>B3</b>          |
| 19200       | B4                 |
| 38400       | B5                 |
| 1200        | B6                 |

To change the Baud rate when using HyperTerminal: -

Eg. If set to B3 (9600 baud) and it is required to set to Baud rate to B2 (4800 baud).

Type **\*** to enter Configuration Mode.

Type **B 2** and press **ENTER**, **(Do not type any further commands at this stage)**.

Close the 9600 Baud HyperTerminal connection.

Open HyperTerminal and set the new connection Baud Rate to 4800 baud.

Type **B** and press **ENTER**, the letter B will be shown followed by B2

Type **Q** and press **ENTER**, data will scroll at the new baud rate.

### Cx- Analogue Output Polar Mode Direction Wraparound

| Setting                      | Configuration code |
|------------------------------|--------------------|
| <b>Wraparound (0 - 539°)</b> | <b>C1</b>          |
| Standard (0-360°)            | C2                 |

## Dx- Diagnostic and Configuration Command

Each of these commands causes a response from the WindObserver II.

| Item   | Command code        | Typical response  |
|--|---------------------|---|
| Type and serial No.                          | <a href="#">D1</a>  | *901001 (where * = E (Unheated unit), F = (Heated unit))                                    |
| Software version                             | <a href="#">D2</a>  | 5.00  |
| Unit configuration                           | <a href="#">D3</a>  | Current configuration:<br>A0 B3 C1 E1 F1 G0000 H1 J1 K1 L1 M2 NA O1 P1 T1<br>U1 V1 X1 Y1 Z1 |
| Analogue ID (if present)                     | <a href="#">D4</a>  | Analogue Active (if fitted) or No analogue fitted.  |
| Anemometer power supply voltage              | <a href="#">D5</a>  | +29.8   |
| Integrity check                              | <a href="#">D6</a>  | See Para 10.7 Bench Tests   |
| Reports direction with a resolution of 1°    | <a href="#">DR0</a> |   |
| Reports direction with a resolution of 0.01° | <a href="#">DR2</a> |   |

## Ex - Full Duplex/Half Duplex Mode

| Setting     | Configuration code |
|-------------|--------------------|
| Full duplex | <a href="#">E1</a> |
| Half duplex | <a href="#">E2</a> |

Note: - Refer also to Para 7.3 Networking Configuration details.

## Fx- Data and Parity Options

| Setting                         | Configuration code |
|---------------------------------|--------------------|
| 8 bits, no parity, 1 stop bit   | <a href="#">F1</a> |
| 8 bits, even parity, 1 stop bit | <a href="#">F2</a> |
| 8 bits, odd parity, 1 stop bit  | <a href="#">F3</a> |

If changing to F2, using a Terminal program then when in configuration mode Type F2 and press Enter, close the terminal program and open a new one with Even parity settings, then type F and press Enter.

## Gx to Gxxxx - Averaging (Digital Outputs only)

| Setting             | Configuration code    |
|---------------------|-----------------------|
| Averaging (Default) | <a href="#">G0000</a> |

Enter the required averaging period in seconds as a four-figure number between 0000 and 3600.

**Hx - Heating (If fitted)**

Heating is autonomous and requires no set-up once activated.

| Setting         | Configuration code |
|-----------------|--------------------|
| <b>Disabled</b> | <a href="#">H1</a> |
| Activated       | <a href="#">H2</a> |

**Jx - Analogue Power-up Tests**

| Setting  | Configuration code |
|--|--------------------|
| Disable analogue power-up tests on switch on             | <a href="#">J0</a> |
| <b>Enable single analogue power-up test on Switch on</b> | <a href="#">J1</a> |
| Enable continual cycling of analogue power-up tests      | <a href="#">J2</a> |
| Disable continual cycling of analogue power-up tests     | <a href="#">J3</a> |

Analogue Power up tests cycle: -

Analogue Output Voltage connections between 0v, 1.25v, 2.5v, 3.75v and 5v.

Analogue Output Current connections between 0mA, 5mA, 10mA, 15mA and 20mA

**Kx – NMEA Settings**

| Setting                    | Configuration code |
|----------------------------|--------------------|
| <b>NMEA string “IIMWV”</b> | <a href="#">K1</a> |
| NMEA string “WIMWV”        | <a href="#">K2</a> |

**Lx - ASCII Message Terminator**

| Setting      | Configuration code |
|--------------|--------------------|
| <b>CR LF</b> | <a href="#">L1</a> |
| LF           | <a href="#">L2</a> |

**Mx to Mxx - Message Format**

| Output format                     | Configuration code  |
|-----------------------------------|---------------------|
| ASCII UV Continuous               | <a href="#">M1</a>  |
| <b>ASCII Polar Continuous</b>     | <a href="#">M2</a>  |
| ASCII UV Polled (tri-state) *     | <a href="#">M3</a>  |
| ASCII Polar Polled (tri-state) *  | <a href="#">M4</a>  |
| NMEA Continuous                   | <a href="#">M5</a>  |
| Binary Tunnel Continuous          | <a href="#">M6</a>  |
| Binary UV Continuous              | <a href="#">M7</a>  |
| Binary Polar Continuous           | <a href="#">M8</a>  |
| ASCII Tunnel Continuous           | <a href="#">M12</a> |
| ASCII Tunnel Polled (tri-state) * | <a href="#">M13</a> |

\* If units are to be networked, they MUST be given unique Unit Identifiers.

---

**Nx – Unit Identifier Address**

| <b>Item</b>            | <b>Options</b>        | <b>Command</b>    |
|------------------------|-----------------------|-------------------|
| <b>Unit Identifier</b> | <b>A... -(A to Z)</b> | <b>N&lt;A&gt;</b> |

If used in a multi-drop system then it is recommended that ID's A to F and K, M, N and P are not used, as these characters can be present in the data string.

## Ox – ASCII Output Format (Output String Padding)

| Setting                        | Configuration code |
|--------------------------------|--------------------|
| Comma Separated Variable (CSV) | <a href="#">O1</a> |
| Fixed Field                    | <a href="#">O2</a> |

### Example data strings:-

| POLAR   | NMEA  |
|---|---|
| CSV data changing to error status code condition.         | CSV data changing to error status code condition.         |
| □A,235,000.77,M,00,□0A                                    | \$IIMWV,191,R,000.55,M,A*19                               |
| □A,,,M,04,□24   | \$IIMWV,,R,,M,V*29  |
| Fixed Field data changing to error status code condition. | Fixed Field data changing to error status code condition. |
| □A,266,000.73,M,00,□08                                    | \$IIMWV,191,R,000.55,M,A*19                               |
| □A,999,999.99,M,04,□0A                                    | \$IIMWV,999,R,999.99,M,V*07                               |

## Px - Output Rate

| Outputs per second | 1                  | 2                  | 4                  | 5                  | 8                  | 10                 |
|--------------------|--------------------|--------------------|--------------------|--------------------|--------------------|--------------------|
| Configuration code | <a href="#">P1</a> | <a href="#">P3</a> | <a href="#">P2</a> | <a href="#">P4</a> | <a href="#">P5</a> | <a href="#">P6</a> |

## Q- Measurement Mode

See Section 8.3.

RWASHORT XX (Short term number)

Where XX = 10 to 60, associated with Mode 14 and Mode 15 averaging.

RWALONG XX (Long term number)

Where XX = 1 to 10, associated with Mode 14 and Mode 15 averaging.

## Tx - Analogue Output Voltage or Current settings (if fitted)

| Setting                  | Configuration code |
|--------------------------|--------------------|
| Voltage (0 to 5V)        | <a href="#">T1</a> |
| Voltage (-2.5V to +2.5V) | <a href="#">T2</a> |
| Current (4-20mA)         | <a href="#">T3</a> |

## Ux – Digital Output Units

| Units              | metres/sec (m/s)   | knots (knots)      | miles / hour (MPH) | kilometre/hour (kph) | feet / minute (fpm) |
|--------------------|--------------------|--------------------|--------------------|----------------------|---------------------|
| Configuration code | <a href="#">U1</a> | <a href="#">U2</a> | <a href="#">U3</a> | <a href="#">U4</a>   | <a href="#">U5</a>  |

### Vx- Vertical Output Padding

| Setting                         | Configuration code |
|---------------------------------|--------------------|
| Disable vertical output padding | V1                 |
| Enable vertical output padding  | V2                 |

### Xx - 45° Alignment Offset/Inverted Operation

| Setting                              | Configuration code | Notes  |
|--------------------------------------|--------------------|--|
| Align U axis with transducer axis    | X1                 | X1. Aligns U axis with North/South axis.   |
| Align U axis +45° to transducer axis | X2                 | X2. This re-aligns both U&V and polarity 45° to transducer axis.   |
| Reverses Polar Direction             | X3                 | X3 reverses reported polar direction to allow the instrument to be mounted upside down. N.B. Does NOT affect UV alignment (Mode 1, 3). |
| Align @ 45° from North               | X4                 | X4 set polar alignment at 45 degrees from North when instrument is mounted upside down. Does NOT affect UV alignment (Mode 1, 3).      |

Figure 3 shows the polarity of U and V if the wind components along the U and V axis are blowing in the direction of the respective arrows.

Figure 3 UV Polarity

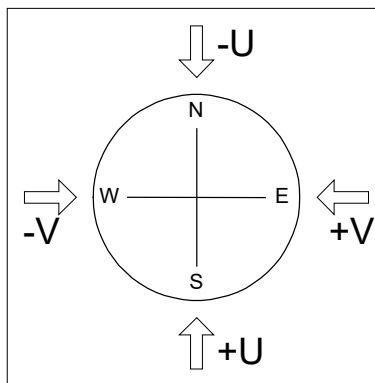

### Yx – Analogue Output, Channel 3 (if fitted).

| Setting     | Configuration code |
|-------------|--------------------|
| Status      | Y1                 |
| Temperature | Y2                 |

### Zx – Analogue Output Scaling (if analogue outputs fitted).

| Setting            | ± 10 | ±20 | ±30 | ±40 | ±50 | ±60 | ±70 |
|--------------------|------|-----|-----|-----|-----|-----|-----|
| Configuration code | Z1   | Z2  | Z3  | Z4  | Z5  | Z6  | Z7  |

## 9. VIEW AND LOG DATA WITH WINDVIEW SOFTWARE

### 9.1. Introduction

Gill WindView Software can be downloaded from

<http://gillinstruments.com/main/software.html>

Gill Wind View will run on PC's with Windows XP onwards operating systems.

### 9.2. Connect to an Instrument using Gill WindView Software

Open WindView Software.

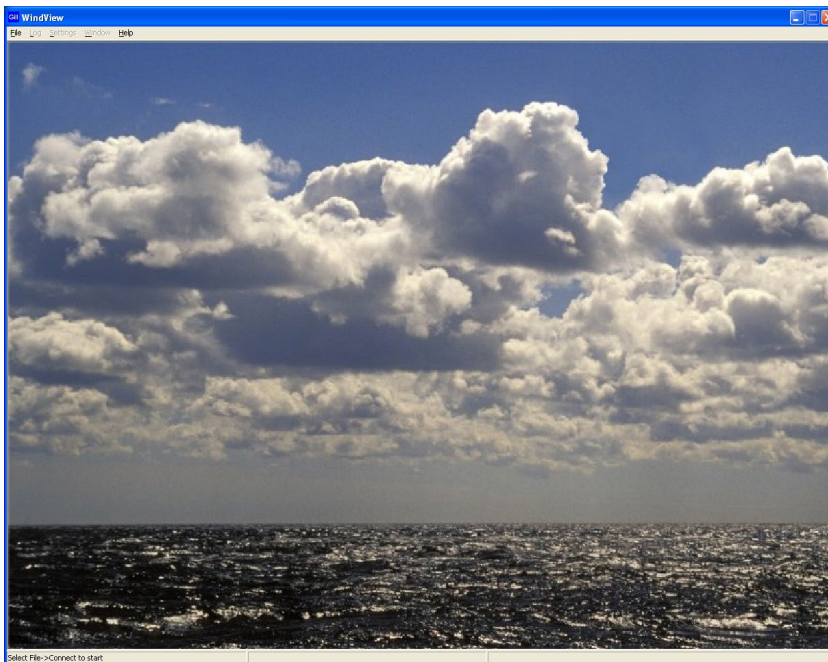

Select File/Connect.

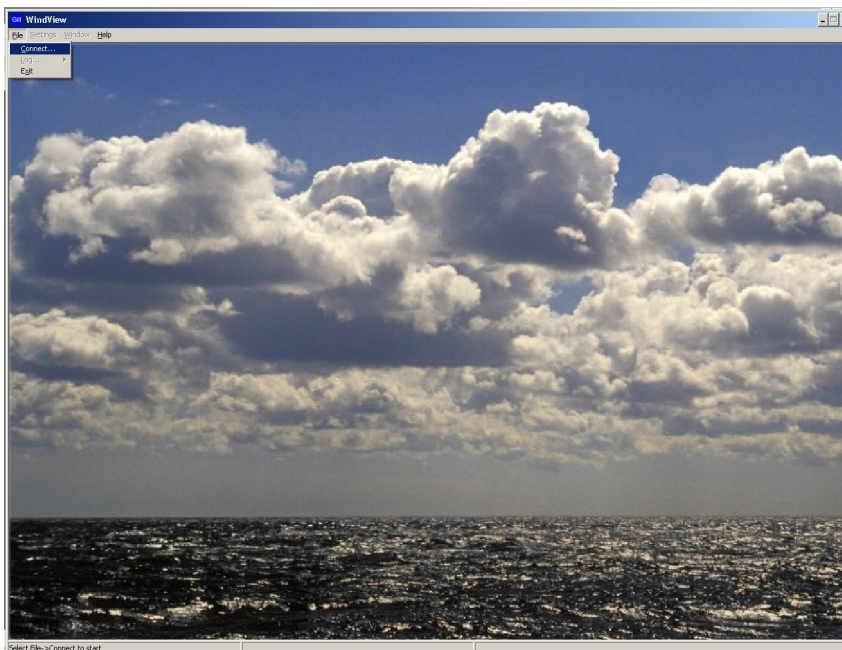

The default connection name is Anemometer 1, it can be re-named if required.

Select the Output Format to match the Sensor format i.e. the WindObserver default format is Gill Polar (2 axis).

If the WindObserver were set for UV or NMEA output then choose the appropriate format setting from the drop down menu.

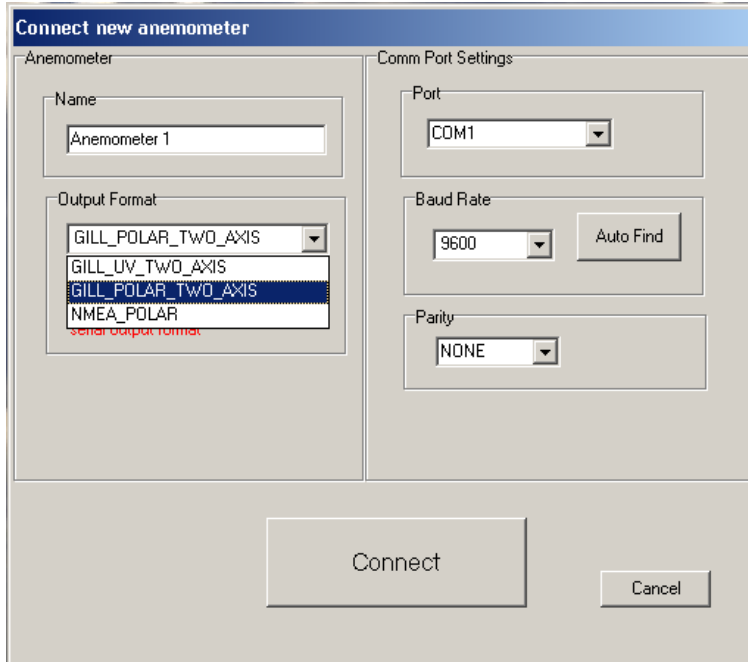

From the Port drop down menu select the PC COM Port to which the WindObserver is connected to e.g. COM 9.

Select the Baud rate setting from the drop down menu to match that of the Windobserver, the WindObserver default baud rate is 9600 baud.

Leave Parity setting at None.

Click on Connect.

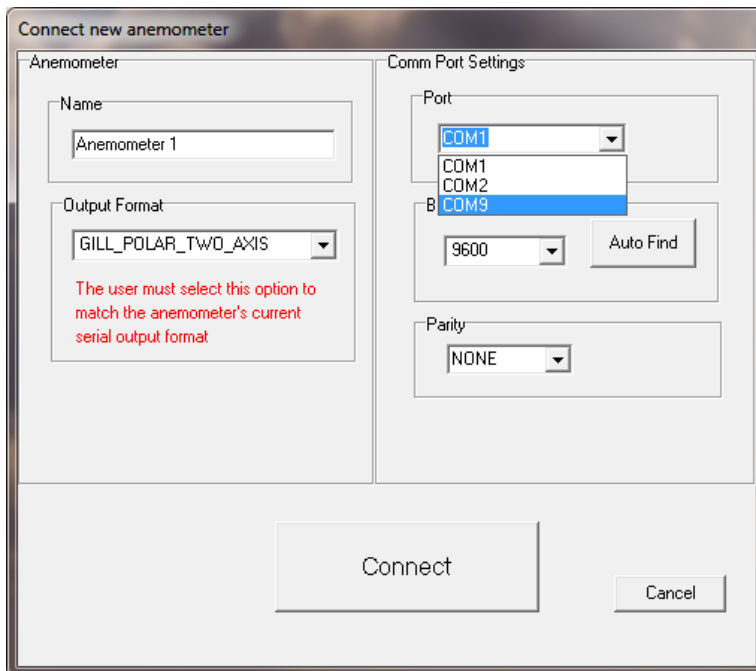

The Data button screen will show the WindObserver data scrolling on screen updated at the WindObserver Output rate.

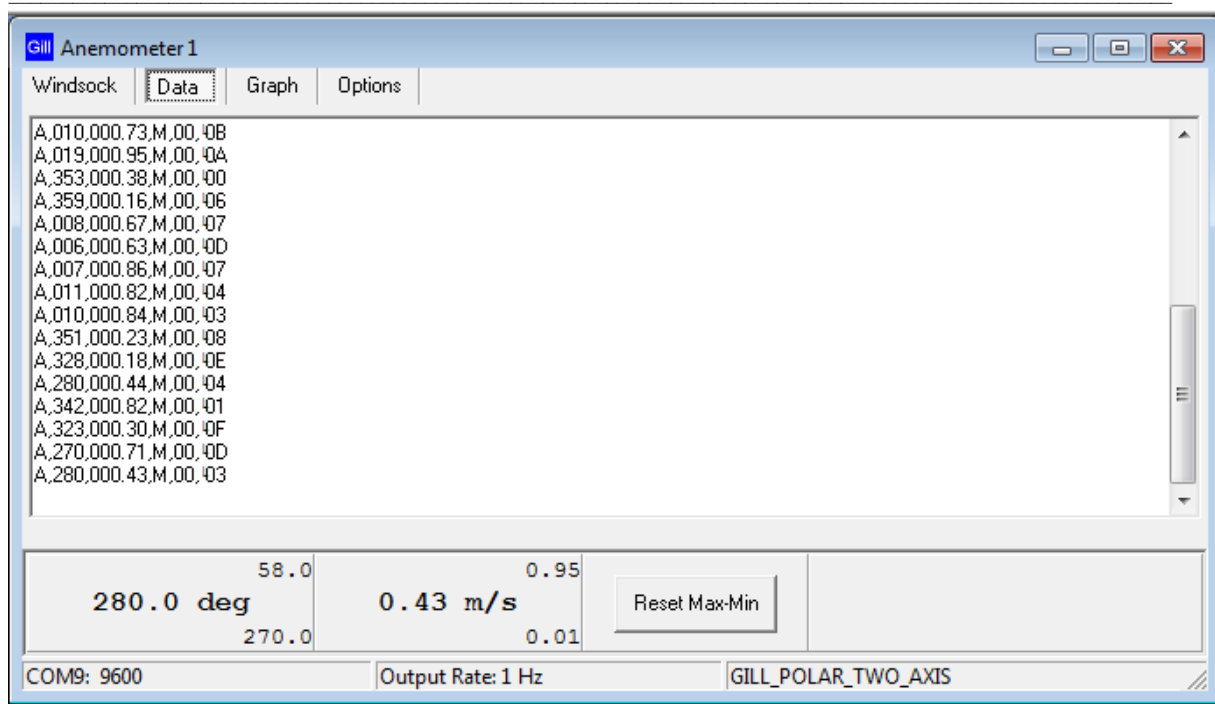

### 9.3. WindSock Function

Click on the WindSock button to give a Direction display and digital readout of Direction and Wind Speed:-

On screen Maximum and Minimum readings of Wind speed and Directions are also displayed digitally and can be reset using the Reset Max/Min button.

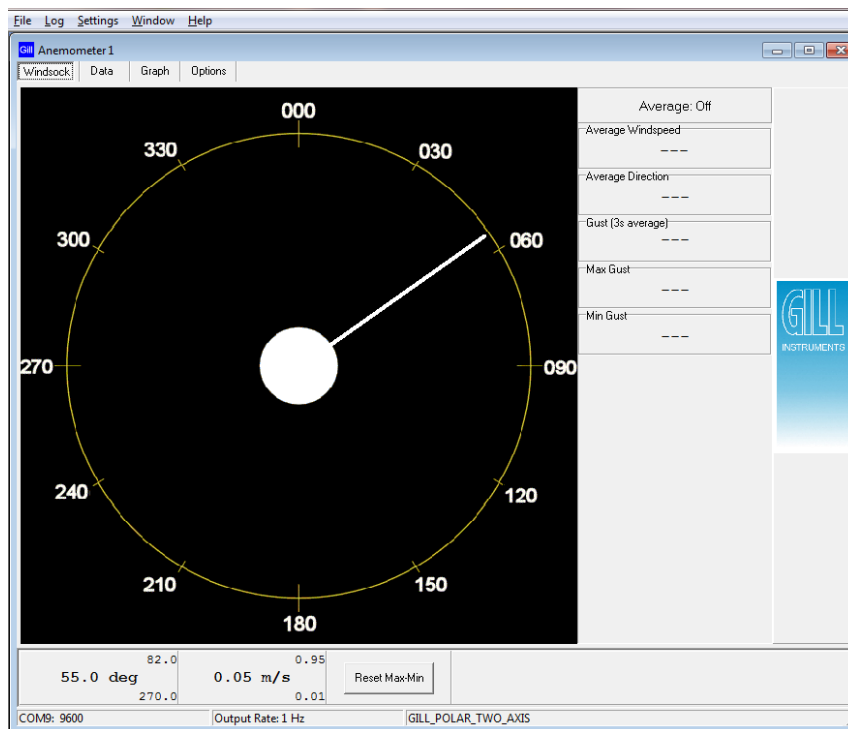

## 9.4. Logging Data.

To Log WindObserver data, from the WindView top menu select Settings/Logging. If Segmented log files are required tick the Enable box and select the length of each log file.

Tick the Record Formatting box options for Appending PC Time and Date Stamp and sequential line numbering as required.

Date and Time are taken from the PC clock.

The Log Description box allows a free text file header to be added to the log file.

Save the Log file to the required Directory.

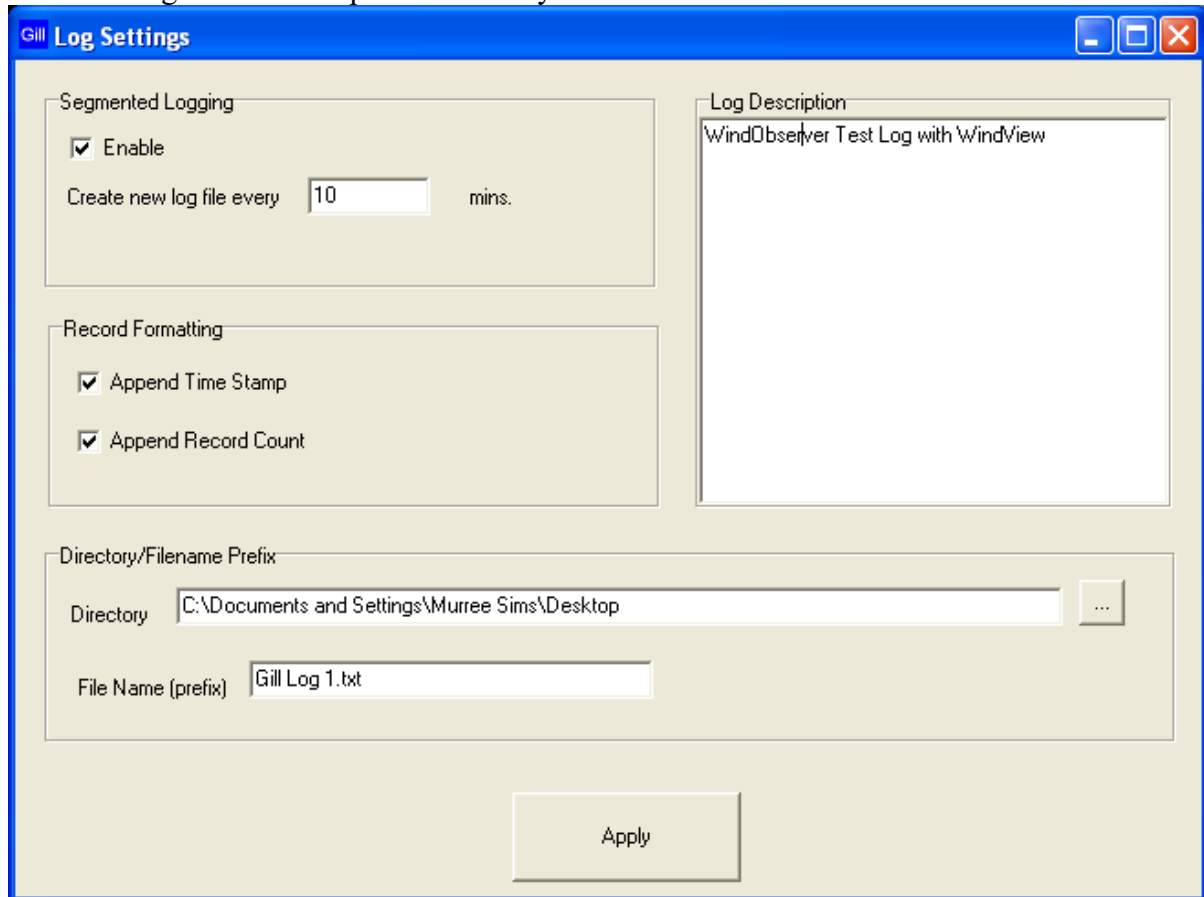

Click on Apply gives the following screen, click on OK:-

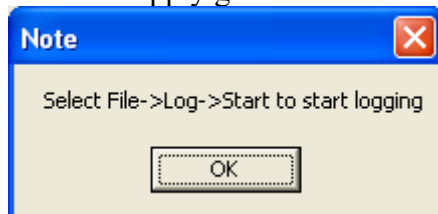

### To Start Logging.

From the top menu select Log.

Click on Log/Start to commence logging.

### To Stop Logging.

From the top menu select Log.

Click on Log/Stop to stop logging.

The logged data is saved to a PC text file that can be opened with Notepad or equivalent and the following example illustrates the saved time/date stamped WindObserver data.  
Note: The Data and time information are taken from the PC Clock.

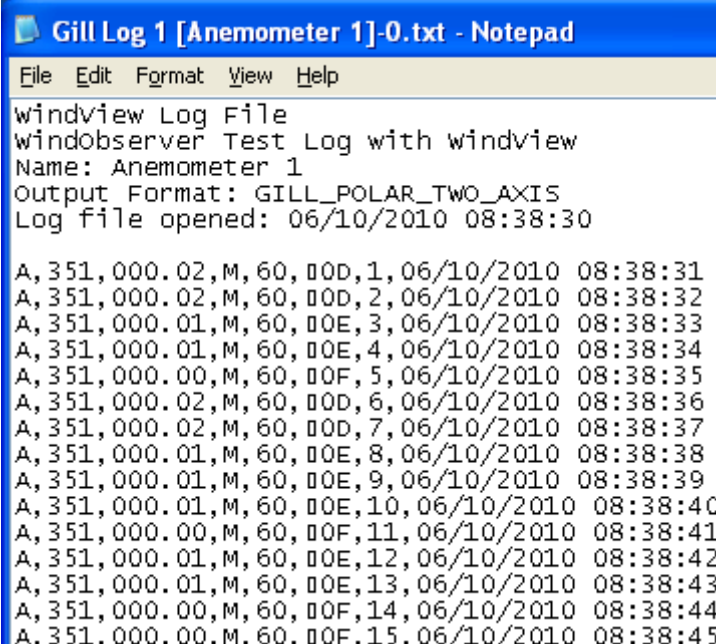

```
Gill Log 1 [Anemometer 1]-0.txt - Notepad
File Edit Format View Help
windview Log File
windObserver Test Log with windview
Name: Anemometer 1
Output Format: GILL_POLAR_TWO_AXIS
Log file opened: 06/10/2010 08:38:30

A,351,000.02,M,60,00D,1,06/10/2010 08:38:31
A,351,000.02,M,60,00D,2,06/10/2010 08:38:32
A,351,000.01,M,60,00E,3,06/10/2010 08:38:33
A,351,000.01,M,60,00E,4,06/10/2010 08:38:34
A,351,000.00,M,60,00F,5,06/10/2010 08:38:35
A,351,000.02,M,60,00D,6,06/10/2010 08:38:36
A,351,000.02,M,60,00D,7,06/10/2010 08:38:37
A,351,000.01,M,60,00E,8,06/10/2010 08:38:38
A,351,000.01,M,60,00E,9,06/10/2010 08:38:39
A,351,000.01,M,60,00E,10,06/10/2010 08:38:40
A,351,000.00,M,60,00F,11,06/10/2010 08:38:41
A,351,000.01,M,60,00E,12,06/10/2010 08:38:42
A,351,000.01,M,60,00E,13,06/10/2010 08:38:43
A,351,000.00,M,60,00F,14,06/10/2010 08:38:44
A,351,000.00,M,60,00F,15,06/10/2010 08:38:45
```

The logged Wind Data .txt file can be imported into Microsoft Excel if it is required to manipulate the data or graph plot the data.

## 10. MAINTENANCE & FAULT-FINDING

### 10.1. Cleaning and Handling

When installing the unit handle with lint free gloves and degrease the unit to reduce the build up of deposits.

If there is any build up of deposit on the unit, it should be gently cleaned with a cloth, moistened with soft detergent. Solvents should not be used, and care should be taken to avoid scratching any surfaces. The unit must be allowed to defrost naturally after being exposed to snow or icy conditions, do NOT attempt to remove ice or snow with a tool.

**Do NOT remove black “rubber” transducer caps.**

### 10.2. Servicing

There are no moving parts or user-serviceable parts requiring routine maintenance.

Opening the unit or breaking the security seal will void the warranty and the calibration.

In the event of failure, prior to returning the unit to your authorised Gill distributor, it is recommended that:

- All cables and connectors are checked for continuity, bad contacts, corrosion etc.
- A bench test is carried out as described in Section 10.7.
- Contact your supplier for advice if failure persists.

### 10.3. Fault-finding

| Symptom  | Solution   |
|--|--|
| No output  | <p>Check DC power to WindObserver II, cable and connections.</p> <p>Check comms settings of WindObserver II (as detailed in Section 9) and host system match, including correct Com port.</p> <p>Check unit is in Continuous mode.</p> <p>Check that in-line communication devices are wired correctly.</p> <p>NOTE: It is usual for Anemometer TX + to be connected to converter device RX +.</p> |
| Corrupted output   | <p>Check comms settings of WindObserver II and host system match.</p> <p>Try a slower baud rate.</p> <p>Check cable lengths and type of cable.</p>   |
| One way communication  | <p>Check wiring is in accordance with the manual.</p>  |
| Failed / Incorrect WindObserver II output, data invalid flag | <p>Check that transducer path is not blocked.</p>  |

## 10.4. Safe Mode

If a unit is received that will not communicate or the configuration settings are not known then Safe Mode can be used to establish communication with the WindObserver II and change configuration settings.

Initial Set Up.

The WindObserver 65 RS422 Pair 1 and Pair 2 TX and RX output connections (4 wires) are connected to a PC via an RS422 to RS232/USB Converter.

Open a Terminal program e.g. Windows HyperTerminal (or use Gill Wind Software as a Terminal program).

Select the required COM port.

Set the Baud rate to 19200 baud (if using the Wind Terminal program it opens at 19200 baud).

To Place the unit into Safe Mode.

Turn off the WindObserver II.

Ensure the Terminal program is set for 19200 baud,

Hold down the PC keyboard \* key and turn on the WindObserver II Power Supply.

The words SAFE MODE should appear on the terminal screen.

If not then power down the WindObserver II, hold the \* key and re-power sensor.

To now check the unit: -

Type D1 and press Enter, to see serial number.

Type D2 and Press Enter to see Firmware version.

Type D3 to see configuration settings,

```
SAFE MODE
D1
F922036
D1
D2
5.00
D2
D3
current configuration :
A0 B2 C1 E1 F1 G0000 H2 J1 K1 L1 M5 NA O2 P1 T1 U1 V1 X1 Y1 Z1
```

Change settings if required.

Type Q and press Enter to go back into measurement mode.

If powering down the instrument and repowering and no change has been made to the baud rate (B command ) then open a new terminal program at the units original baud rate setting (the default setting would be 9600 Bauds).

## 10.5. Returning unit

If the unit has to be returned, it should be carefully packed in the original packaging and returned to your authorised Gill distributor, with a full description of the fault condition.

## 10.6. Status (error) codes

The Status code is sent as part of each wind measurement message.

| Code | Status   | Condition   |
|------|--|---|
| 00   | OK   | Sufficient samples in average period  |
| 60   | OK and heating enabled                         | Sufficient samples in average period  |
| A    | OK   | NMEA data Acceptable  |
| 01   | Axis 1 failed                                  | Insufficient samples in average period on U axis  |
| 02   | Axis 2 failed                                  | Insufficient samples in average period on V axis  |
| 04   | Axis 1 and 2 failed                            | Insufficient samples in average period on both axes   |
| 08   | NVM error                                      | NVM checksum failed, data could be uncalibrated.  |
| 09   | ROM error                                      | ROM checksum failed, data could be uncalibrated.  |
| 10   | System gain at max.                            | Inaccurate data likely  |
| 50   | Marginal system gain                           | Data valid, but marginal operation  |
| 51   | Measurement average building.                  | Data valid but warns that average period not reached when averaging used (non-heat enabled units only). |
| 62   | Heating current tripped or electronic failure, | Valid data still output   |
| 63   | Heater Thermistor open circuit                 | Valid data still output.  |
| 65   | Heating element open circuit                   | Valid data still output, Heater Element or Heater PSU has dropped out/failed                            |
| V    | NMEA data Void                                 | Invalid data output   |

## 10.7. Bench test

Couple the WindObserver II to the host system and power supply, using a known working test cable.

Check that the unit is correctly configured by going into Configuration mode and using [D3](#) See Section 8.4 *Checking the Configuration*.

Check for normal output data, and that the Status Code is OK – 00, 60 or A (for NMEA format).

If the status code is other than these, refer to Section 10.6 Status (error) codes.

Use an office fan or similar to check that the unit is sensing wind, turning the unit to simulate changing wind direction and to check that both axes are functioning.

Note that this is a quick functional test. There are no calibration adjustments; the unit is designed NOT to require re-calibration within its lifetime. Gill has provided an Integrity Check, see next page for details.

## Integrity Check Chamber (ICC)

The software to perform the Integrity Check (IC) is incorporated in the latest WindObserver II's.

The IC is designed to:

1. Identify any gross changes in the head geometry that would affect the performance.
2. Provide a zero wind environment to confirm the WindObserverII zero calibration.

The ICC has been designed to be used in an indoor still air environment with an ambient temperature between 17°C and 23°C. When conducting the test it is important that the ICC is assembled on to the WindObserver II head and not touched or moved during the test.

This test is only valid if undertaken with an ICC purchased from Gill.

## Integrity & Zero Wind Check

### Zero Wind Check

Configure your PC to run HyperTerminal and assemble the ICC by inserting the reflector cases and the two halves of the ICC onto the WindObserver II. The ICC must be retained using the strips provided. Then:

1. Ensure that the WindObserver II is set in factory default mode. For Factory default settings see section 8.4.
2. Enter Measurement Mode and Record/View data

In still air wind speed measurements should not exceed 0.03m/s. If wind speed exceeds 0.03m/s contact Gill Instruments.

### Integrity Check

Ensure the ICC is assembled correctly on the WindObserver II. Using HyperTerminal, enter Configuration Mode as described in Section 8.

Enter D6.

A typical report as shown below will be displayed.

```
D6
ALIGNMENT LIMITS: U=2424,2524
                  V=2434,2434
ALIGNMENT U:2474 *PASS*
ALIGNMENT V:2484 *PASS*
D6
```

If 'Refer to Manual' is shown check test temperature conditions are 17 to 23 deg C and tested under zero wind condition.

If there has been no significant changes to The WindObserver II head configuration then \*PASS\* will confirm correct operation.

Alterations to the head geometry can result in a \*FAIL\* or 'Insufficient Samples' message. If this occurs please contact Gill Instruments.

## 11. APPENDICES

### 11.1. Glossary & Abbreviations

| Item                     | Meaning   |
|--------------------------|---|
| CAL                      | Calibration   |
| CR                       | Carriage Return   |
| CRLF                     | Carriage Return Line Feed   |
| CSV                      | Comma Separated Variable  |
| ENG                      | Engineering   |
| ESC                      | ESCape key on keyboard used to stop any process that is being executed                                  |
| ETX                      | End of string character   |
| FAC                      | Factory   |
| fpm                      | Feet per minute   |
| GND                      | GrouND  |
| HEX                      | HEXadecimal   |
| I/P                      | InPut   |
| IP66                     | Protection Classification   |
| KPH                      | Kilometres per Hour   |
| LF                       | Line Feed   |
| m/s                      | Metres per second   |
| MAG                      | MAGNitude - scalar reference to wind speed  |
| MAX                      | MAXimum   |
| MPH                      | Miles per Hour  |
| NEMA                     | National Electrical Manufacturers Association   |
| NMEA 0183<br>(version 3) | National Marine Electronics Association standard for interfacing marine electronic navigational devices |
| No:                      | Number  |
| NVM                      | Non-Volatile Memory   |
| O/P                      | Output  |
| PC                       | IBM compatible Personal Computer  |
| PCB                      | Printed Circuit Board   |
| POR                      | Power On Reset  |
| ROM                      | Read Only Memory  |
| RS232                    | Communications standard   |

| Item  | Meaning                   |
|-------|---------------------------|
| RS422 | Communications standard   |
| RS485 | Communications standard   |
| RTS   | Request To Send           |
| RX    | Receive                   |
| RXD   | Received Data             |
| S/W   | SoftWare                  |
| SOS   | Speed Of Sound            |
| SEC   | SECond                    |
| STX   | Start of string character |
| TERM  | TERMinal                  |
| TX    | Transmit                  |
| TXD   | Transmitted Data          |
| +VE   | Positive                  |
| -VE   | Negative                  |
| WRT   | With Respect To           |

## 11.2. Guarantee

For terms of guarantee contact your supplier or refer to the Gill Instruments Terms & Conditions here:

<https://gill.group/wp-content/uploads/Gill-Group-Company-Terms-Conditions-of-Sale-9170-0003-Issue-02-March-20...pdf>

Warranty is void if the green security seal covering base nuts is damaged or broken, or the transducer caps have been damaged.

### 11.3. Principle of operation

The WindObserver II measures the times taken for an ultrasonic pulse of sound to travel from the North transducer to the South transducer, and compares it with the time for a pulse to travel from S to N transducer. Likewise times are compared between West and East, and E and W transducer.

If, for example, a North wind is blowing, then the time taken for the pulse to travel from N to S will be faster than from S to N, whereas the W to E, and E to W times will be the same. The wind speed and direction (and the speed of sound) can then be calculated from the differences in the times of flight on each axis. This calculation is independent of factors such as temperature.

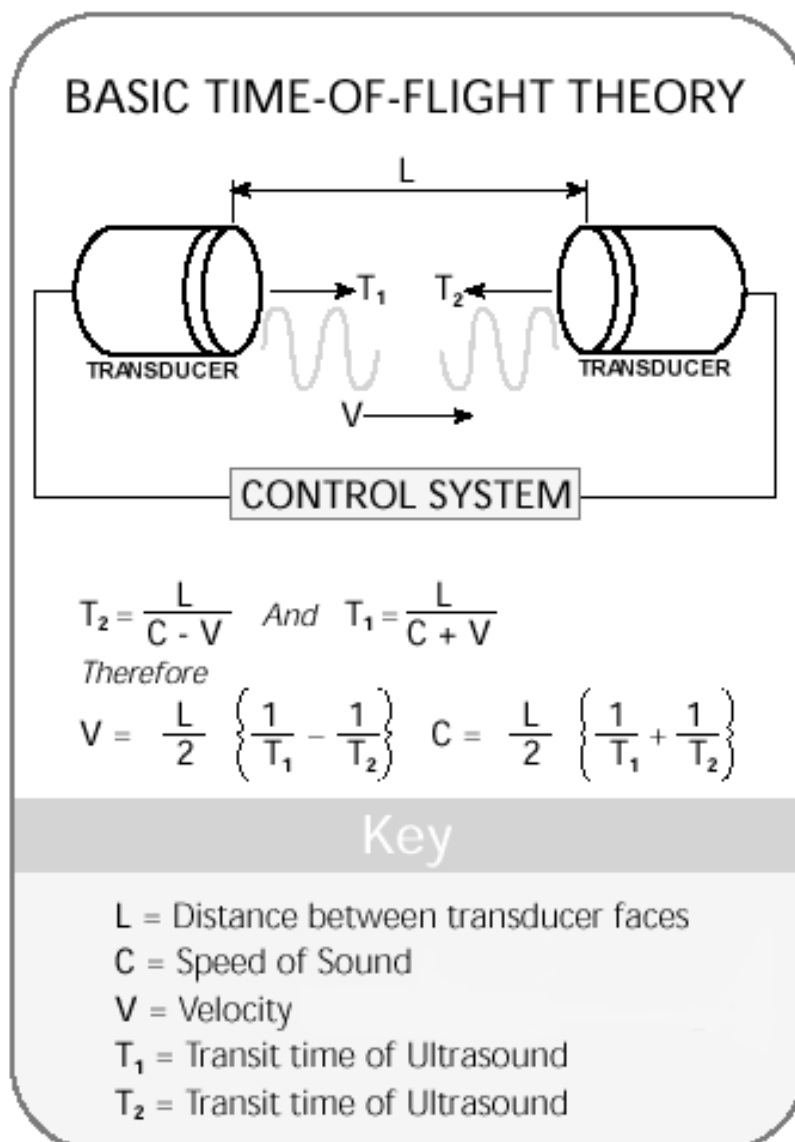

## 12. FCC

WindObserver 2 complies with part 15 of the FCC Rules. Operation is subject to the following two conditions:-

- (1) This device may not cause harmful interference, and
- (2) This device must accept any interference received, including interference that may cause undesired operation

This equipment has been tested and found to comply with the limits for a Class A digital device, pursuant to part 15 of the FCC Rules. These limits are designed to provide reasonable protection against harmful interference when the equipment is operated in a commercial environment. This equipment generates, uses, and can radiate radio frequency energy and, if not installed and used in accordance with the instruction manual, may cause harmful interference to radio communications. Operation of this equipment in a residential area is likely to cause harmful interference in which case the user will be required to correct the interference at his own expense.